

# TABLE OF CONTENTS

USERS MANUAL P/N 29220  
3660XP-20

## SECTION I

### CRANE INSTALLATION INSTRUCTIONS

CRANE INSTALLATION INSTRUCTIONS .....	F1359-F .....	1-1
MOUNTING PATTERN .....	50654-C .....	1-3
ELECTRICAL INSTALLATION .....	50378-A .....	1-4
HYDRAULIC INSTALLATION .....	50026-A .....	1-5
ENGINE CONTROL RECEIVER INSTALLATION .....	F1214-D .....	1-6
STABILITY PROCEDURE .....	F691-G .....	1-7
STABILITY TEST RESULTS .....	F691-G .....	1-8

## SECTION II

### GENERAL OPERATION, INSPECTION, AND MAINTENANCE

CRANE SAFETY RULES .....	F1122-B .....	1-9
INTRODUCTION .....	F1111-D .....	1-11
OPERATING PRACTICES/RESTRICTIONS .....	F1637-A .....	1-12
INSPECTION AND MAINTENANCE .....	F1113-D .....	1-15
MONTHLY INSPECTION REPORT .....	F1123-B .....	1-17
ANNUAL INSPECTION REPORT .....	F1507-0 .....	1-18
STANDARD HAND SIGNALS FOR CRANE OPERATIONS .....	F2409-0 .....	1-21

## SECTION III

### CRANE SYSTEMS AND TROUBLESHOOTING

PENDANT CONTROL SYSTEM .....	F1126-D .....	2-1
SAFETY SYSTEM .....	F1769-0 .....	2-2
PROPORTIONAL HYDRAULIC SYSTEM .....	F1668-A .....	2-3
BASIC TROUBLESHOOTING .....	F1117-G .....	2-5
CONTROL TROUBLESHOOTING CHART .....	F1796-A .....	2-6
TRUBLESHOOTING SAFETY SYSTEM .....	F1254-A .....	2-7
TRUBLESHOOTING PROPORTIONAL SYSTEM .....	F1447-B .....	2-8
DEUSTCH CONNECTORS & PINS .....	F2435-0 .....	2-9

## SECTION V

### CRANE SPECIFICATIONS

LIFTING CAPACITIES .....	F1118-E .....	3-1
POWER FUNCTIONS AND SPEEDS .....	F1118-E .....	3-1
BOLT AND LUBRICATION SPECS .....	F1118-E .....	3-2
CRANE LUBRICATION POINTS .....	F1118-E .....	3-3



F2630-0  
1/24/20

HOUSTON, TEXAS  
FAX: (800) 824-5559 (USA & Canada)  
FAX: (713) 688-6324  
PHONE: (713) 688-5533  
[www.liftmoore.com](http://www.liftmoore.com)

# TABLE OF CONTENTS

USERS MANUAL P/N 29220  
3660XP-20

## SECTION VI PARTS

BOX PARTS LIST.....	F2629-0.....	4-1
CRANE ASSEMBLY II.....	DWG.29218-0.....	4-2
PENDANT CONTROL.....	DWG.24694-H.....	4-3
RELAY BOARD.....	DWG.22569-C.....	4-4
BAIL ATB.....	DWG.58435-D.....	4-5
BOOM-BODY ASSEMBLY.....	DWG.29217-0.....	4-6
ELEVATION CYLINDER ASSEMBLY.....	DWG.20630-A.....	4-7
BODY ASSEMBLY.....	DWG.29216-0.....	4-8
MANIFOLD ASSEMBLY.....	DWG.29230-0.....	4-9
MANIFOLD PRE-ASSEMBLY.....	DWG.24993-B.....	4-10
BASE-HOUSING ASSEMBLY.....	DWG.29214-0.....	4-11
HYDRAULIC SWIVEL.....	DWG.28161-0.....	4-12
BOOM ASSEMBLY – 20 FT.....	DWG.29264-0.....	4-13
BOOM OUTER ASSEMBLY – 20 FT.....	DWG.23020-B.....	4-14
BOOM INNER ASSEMBLY – 20 FT.....	DWG.29262-0.....	4-15
WINCH.....	DWG.32283-A.....	4-16
WINCH BRAKE.....	DWG.50231-B.....	4-17
ROTATION SPEED REDUCER.....	DWG.27128-0.....	4-18
ELECTRICAL WIRING HARNESS.....	DWG.25125-A.....	4-19
ELECTRICAL SCHEMATIC.....	DWG.50826-A.....	4-20
HYDRAULIC SCHEMATIC.....	DWG.50801-C.....	4-21
DECAL DIAGRAM.....	DWG.58329-C.....	4-22
TRAVEL BLOCK ASSY.....	DWG.24081-C.....	4-23
WARRANTY.....	F1442-A.....	



F2630-0  
1/24/20

HOUSTON, TEXAS  
FAX: (800) 824-5559 (USA & Canada)  
FAX: (713) 688-6324  
PHONE: (713) 688-5533  
[www.liftmoore.com](http://www.liftmoore.com)

## **MODEL 2525/2550/3660/3055 INSTALLATION INSTRUCTIONS**

Read and understand these instructions completely before starting the work.

Before installing make sure you have all necessary parts. Please refer to the Owner's manual Section 4-1 for the list of parts required for installation. Report any shortages to Liftmoore, Inc. immediately.

1. The mounting surface for the crane must be capable of supporting the rated moment and the maximum load of the crane listed below:

2525: 25000 Ft.-Lbs.	2500 Lbs.
2550: 25000 Ft.-Lbs.	5000 Lbs.
3660: 36000 Ft.-Lbs.	6000 Lbs.
3055: 30000 Ft.-Lbs.	5500 Lbs.

2. Layout the mounting holes for the crane as shown in the drawing No. 50654. Cut the center hole for the crane swivel as shown on this drawing. Mount the crane with four 7/8" bolts of at least Grade 8 quality.

3. A manual disconnect toggle switch with mounting bracket and terminals is provided with the crane. This switch will act as the main power disconnect for the crane. Removing power from the crane during periods of non-use will help to increase the life of the crane's electrical components. The switch should be mounted as near as possible to the crane and in a position which will facilitate its use. Determine the appropriate mounting position for the switch and use the supplied terminals to splice in to the crane's main power cable. Drawing No. 50378 illustrates how to install the disconnect switch and fuse.

4. Install the 30 Amp fuse, which is supplied with the crane, near the battery on the positive line. This fuse is to protect the battery in event of an accidental grounding of the positive wire. Use a section of the wire and the terminals supplied to connect between the battery and the circuit breaker. See drawing No. 50378-A.

5. Run the 10 Ga. battery cable along the inside of the chassis frame to the positive battery terminal and connect it to the battery through the in-line fuse. Install the fuse as close as possible to the battery. See that the cable is protected avoiding sharp edges and heat sources such as the muffler or catalytic converter. Use loom for protection whenever the cable passes through the body. Use the terminal supplied and connect the cable to the bolt located between the pipe nipples in the center of the swivel under the crane.

6. Be certain that the crane and the battery are grounded to the truck chassis. A good ground must exist for the crane to work.

### **HYDRAULIC COMPONENT INSTALLATION**

The following description applies to Liftmoore's Hydraulic Installation Drawing No. 50026.

These cranes require a pump driven by the vehicle's engine. Pumps can be either Power Take Off or Fan Belt drive. For best, smoothest operation the pump needs to supply 6 GPM at 3000 PSI with the engine at 1000 RPM. An example of this pump is Muncie's PK6. At 600 RPM it delivers 3.5 GPM and at 1000 RPM it delivers 6 GPM.

Do not use pumps that will deliver more than 6 GPM at engine speed. 10 GPM is the maximum flow acceptable to the valves in the crane. If a larger pump is installed on the vehicle for other functions, use a pressure compensated flow control valve to restrict the flow to the crane as required above.

A wire control or solenoid throttle advance can be used to increase the engine speed. Liftmoore can supply a solenoid throttle advance kit (Part No. 32592) that includes a control switch to be mounted near the crane. On engines with electronic throttles, the solenoid throttle advance cannot be used, check with the dealer for throttle advance information. Engine speed, start and stop control can be included in the pendant control box if ordered.



**MODEL 2525/2550/3660/3055 INSTALLATION INSTRUCTIONS, Cont.**

A reservoir of at least 10 gallon capacity is recommended. Reservoir capacity will need to be enlarged for increased running time. For run times of 15 minutes or less the 10 gallon capacity is adequate. For longer duty cycles the reservoir size should be increased.

The reservoir should be equipped with a suction line strainer, return line diffuser, and filler/breather cap. A sight gage for displaying fluid level is also advisable. Locate the reservoir as close to the pump as possible and as high as possible above the pump.

A relief valve should be installed at the pump's output to protect the pump from pressure surges. The crane incorporates a relief valve to protect its valves and hoses.

For up to 9 GPM flow the minimum suction line hose size is 1" ID. For the pressure line a 5/8" ID hose is needed. For the return line between the crane and reservoir a 3/4" ID is advised. Hose sizes can be reduced for lower flows.

A 10 Micron return line filter should be installed in a location that allows convenient access to the replaceable cartridge.

7. Connect the hydraulic hoses to the fittings projecting below the crane. The pressure hose must be connected to the port marked "P" (No. 8 size fitting). This is the smaller of the two fittings. The return line to the tank must be connected to the port marked "T" (No. 10 fitting). This is the larger of the two fittings. The port letters are stamped on the bottom of the swivel.

8. DO NOT RUN OIL THROUGH THE CRANE UNTIL THE OIL HAS BEEN FILTERED. A nipple matching the crane fittings is included. Connect the supply and return lines together using this nipple, circulate the oil through the filter to insure a clean supply. After the pump has filtered 1.5 times the reservoir capacity, hook the hoses to the crane. It is now ready to run.

9. Verify that the anti-two-block will stop extension out and winch up when the weight on the device is lifted by either function. Make sure that the weight is on the live or running wire rope. The Crane Assembly drawing in the owner's manual Section 4-2 illustrates how the weight should be installed on the line.

10. READ AND UNDERSTAND THE OPERATOR'S MANUAL BEFORE OPERATING THE CRANE. Operate the crane through all its functions. Check that each switch operates the correct function. Verify speed of the unit with the crane's operation manual.

11. A boom support is required for this crane. Place the support so that the traveling block hook is secured and does not block the truck cab door. On boom rests supplied by Liftmoore the boom is held down by tension on the hoist wire rope.

12. An outrigger must be installed to keep the crane as level as possible under all expected working conditions. Keeping the crane level reduces the loads on the rotation gear. This will also protect the truck's springs, axle and wheels when heavy loads are suspended from the crane. OSHA requirements require a stability test be performed on this installation. See Form 691 in this manual for information on performing this test.

13. Extra rear spring leaves or heavy coil springs may be needed to keep the truck level when the crane is mounted on corner or off center locations.

14. Load Chart Decal #22379 for the 2550 or #22380 for the 3660 is to be placed on the truck body for easy visibility by the user.



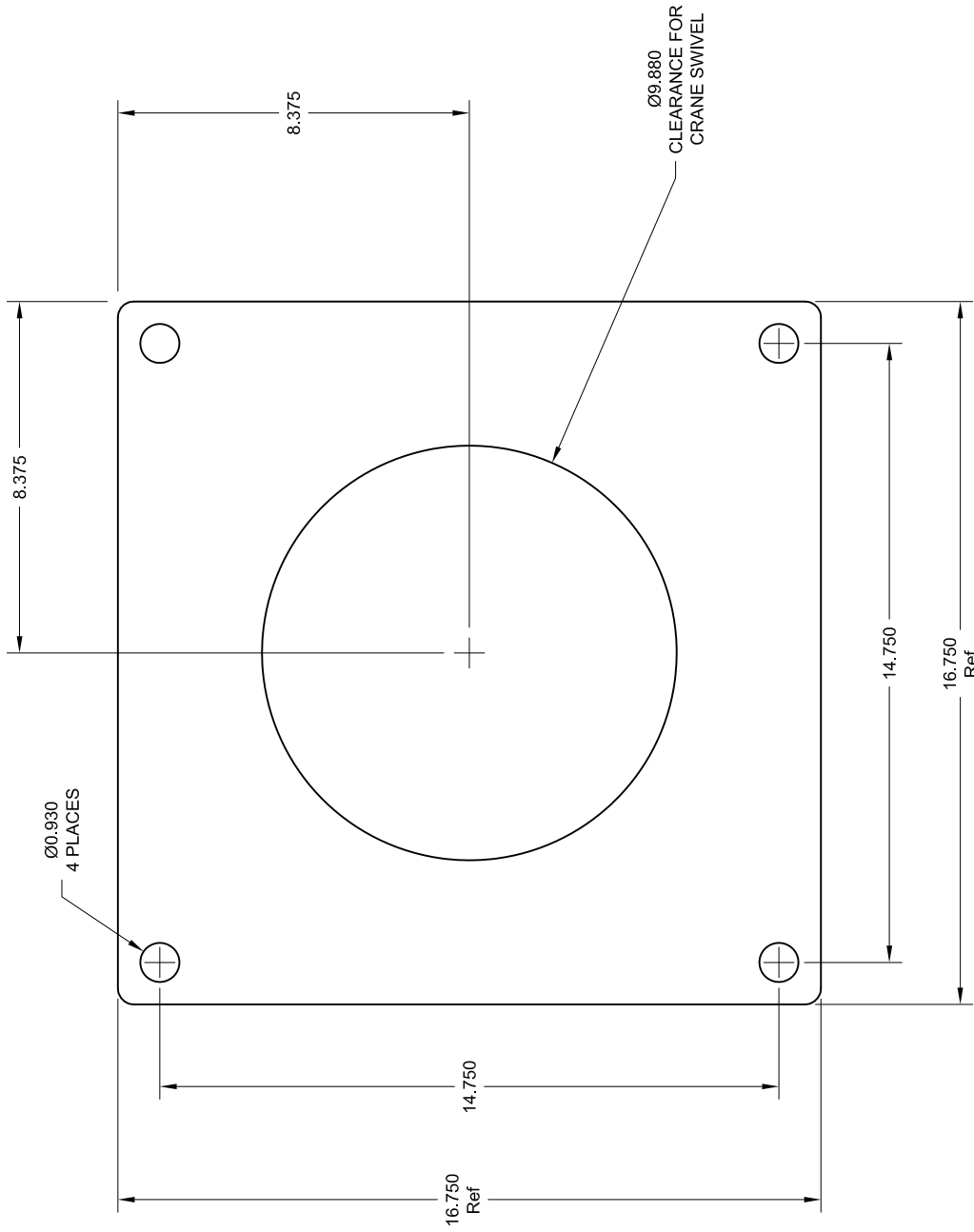

Houston TX  
(713)-688-5533  
www.liftmoore.com

DRWN BY: JC  
DATE: 09/11/08

BASE PLATE 2525/2550/3660/3055

DRAWING NO.

50654-C

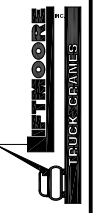

# SUGGESTED WIRING SCHEMATIC FOR LIFTMOORE HYDRAULIC CRANE INSTALLATION

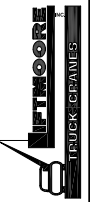
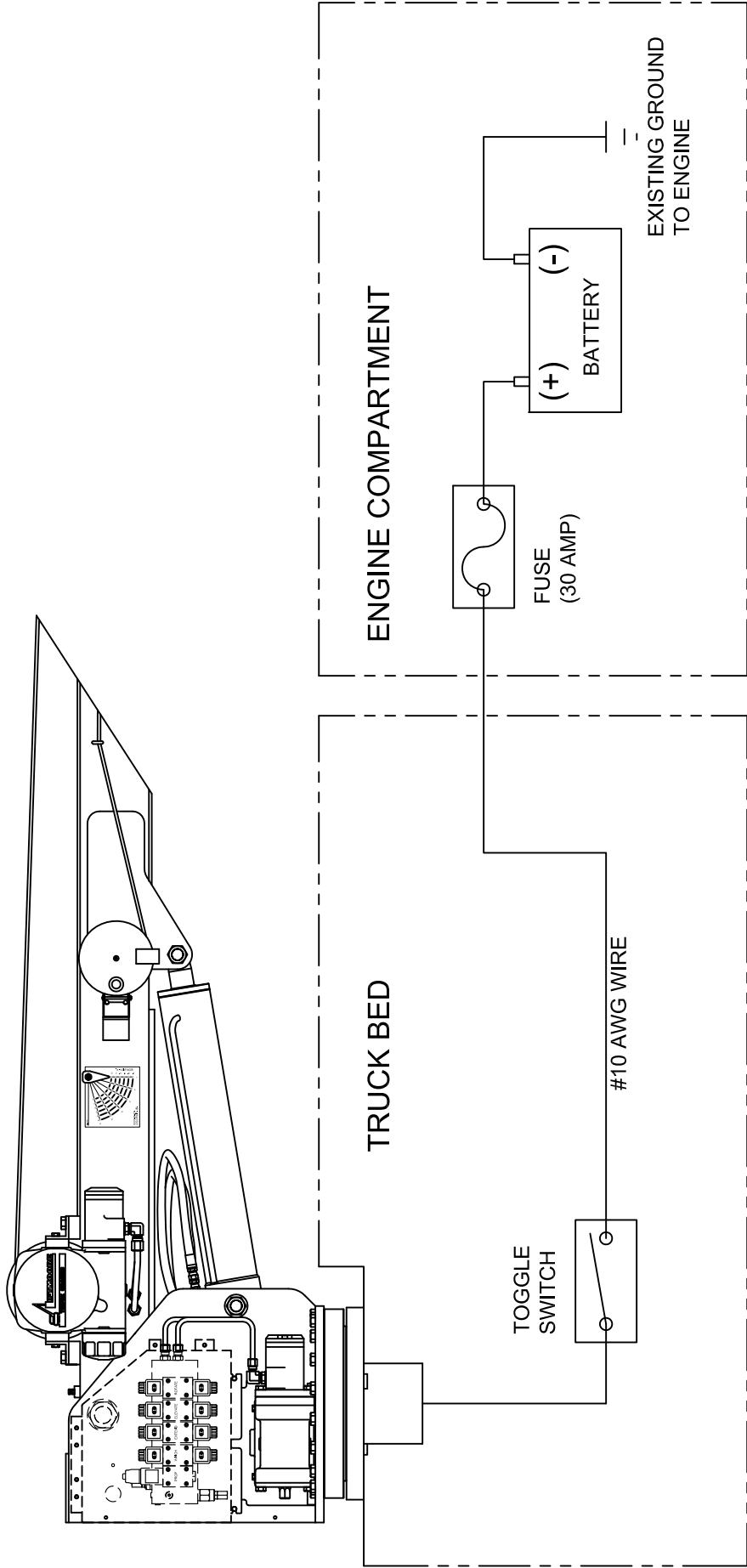

Houston TX  
(713)-688-5533  
www.liftmoore.com

DRWN BY: TV  
DATE: 03/02/06

SCHEM, CRANE ELEC. INSTAL-HYDR

DRAWING NO.

50378-A

SUGGESTED HYDRAULIC SCHEMATIC FOR LIFTMOORE HYDRAULIC CRANE INSTALLATION

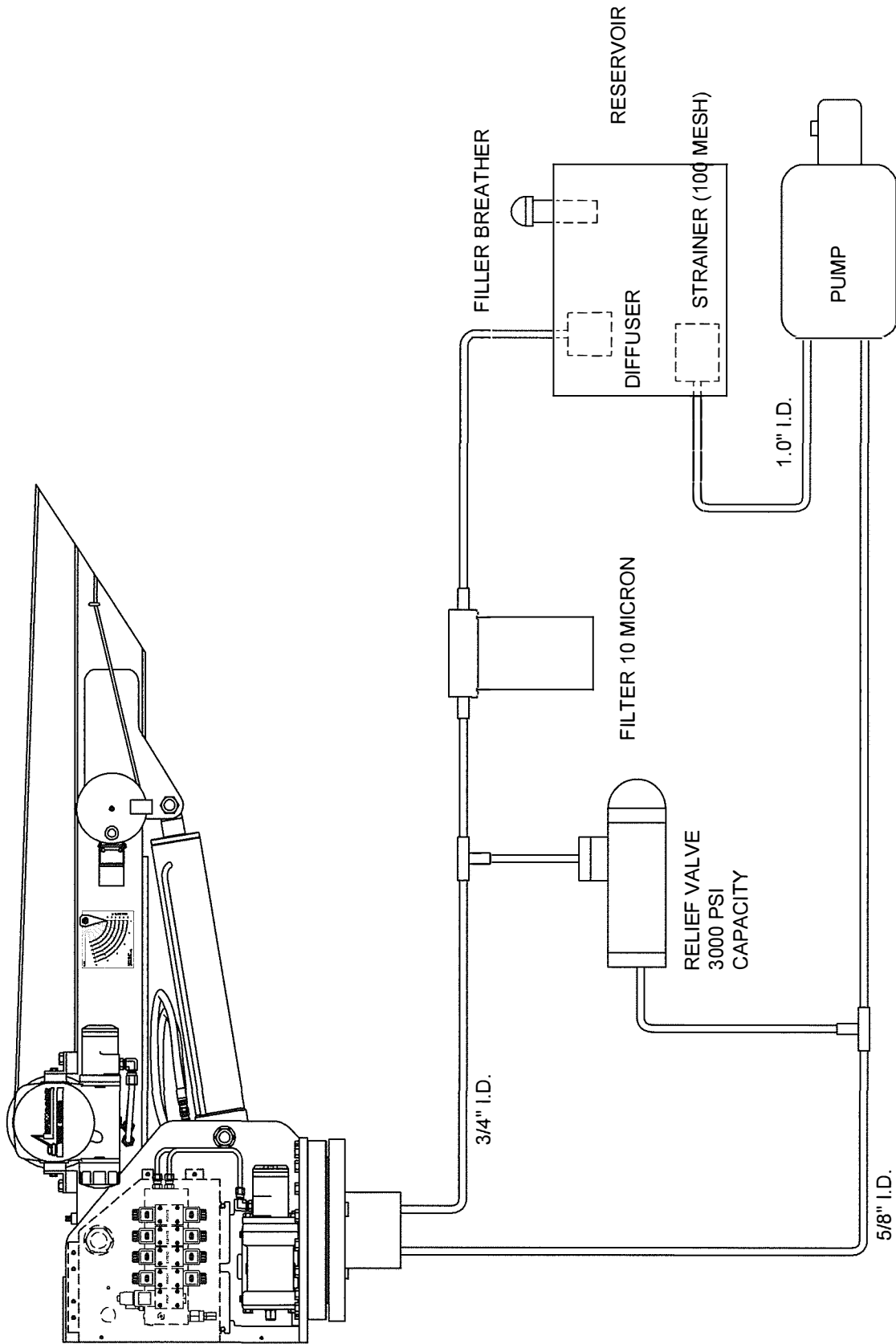

Houston TX  
 (713)-688-5533  
 www.liftmoore.com



SCHEM, CRANE HYD. INSTAL-HYD

DRWN BY: TV  
 DATE: 03/02/06

DRAWING NO.  
**50026-A**

## OPTIONAL ENGINE CONTROL RECEIVER INSTALLATION

The engine control functions allow the user to start and stop the engine and also advance the idle, all from the crane remote pendant control.

The following instructions provide a general guideline for installing and wiring the receiver. Since engine controls vary from manufacture to manufacturer and even from year to year, it is impossible for Liftmoore to maintain specific information on your vehicle. You will have to contact the vehicle and/or engine manufacturer (contact information is provided below). Also, many new vehicles have a provisions for remote engine control built into the ECU, but these functions must be activated and/or programmed by a dealer or authorized service center.

### MOUNTING THE RECEIVER

The receiver should be mounted vertically with the antenna up. For best reception, it should be mounted in cab in line of site of operator. Since interfacing connections will generally be inside the cab, a good mounting place is the inside, back the cab with the antenna visible through the back glass. The receiver can be mounted outside of the cab, however it should NOT be mounted inside the engine compartment because of interference generated by the engine.

### ENGINE START

Engine start is accomplished by splicing the brown wire on the engine receiver control harness with the ECU start circuit.

### WARNING!

Engine start may bypass some manufactures safety functions such as clutch or neutral interlock. It is the installer's responsibility to ensure safe and proper installation.

### ENGINE STOP

If the ECU is not equipped with a remote engine kill circuit then a normally closed relay must be installed in the ECU power or engine run circuit. The gray wire on the engine control receiver harness is then connected to the solenoid coil. Activating the circuit will open the solenoid, killing the engine.

### NOTE!

It is advisable to include a small jumper wire that can be installed to bypass the solenoid should it fail, otherwise the engine would not run.

### ADVANCED IDLE

Many new diesel engines have an advanced idle control circuit built into to the ECU. Some automatically advance the idle when the PTO is activated. This feature may have to be activated and/or programmed by the dealer.

### NOTE!

Some engines also require activating a PTO circuit to prevent "Service Engine Soon" or other erroneous errors during PTO operation.

For gas engines or engines without this feature, an after-market throttle advance will have to be purchased separately.

## CONTACT INFORMATION

Your truck or engine dealer should be able to provide you with further assistance. Also check the manufacturer's body builder manual (some provided online). Before calling, please have your vehicles make, model, year, engine and transmission size and manufacturer, and VIN if available.

Ford Body Builders Advisory Service	1.877.840.4338
GM Upfitter Integration	1.800.875.4742
Peterbilt	1.940.591.4000
Caterpillar	1.800.847.4986
Cummins	1.800.343.7357
Dodge	
Navistar	1.800.336.4500

[www.fleet.ford.com/truckbbas](http://www.fleet.ford.com/truckbbas)  
[www.gmupfitter.com](http://www.gmupfitter.com)

[Rammbg@chrysler.com](mailto:Rammbg@chrysler.com)

HOUSTON, TEXAS  
 FAX: (800) 824-5559 (USA & Canada)  
 FAX: (713) 688-6324  
 PHONE: (713) 688-5533  
[www.liftmoore.com](http://www.liftmoore.com)



## VEHICLE STABILITY TEST

12/6/12

Liftmoore, Inc.  
Form No. 691-G  
Revised 1/30/2013

OSHA requires a stability test be completed by the installer. A qualified person shall perform this test. Please call Liftmoore for any assistance required in completing this test.

### Test Preparations:

- Use as level of a test site as possible.
- Engage parking brake on vehicle.
- Set outriggers, jackstands, or other stability device in place.
  - Vehicle tires should remain in contact with the ground.
  - The vehicle should be level.

### Fill out test form:

- Complete the vehicle and crane data at the top of Page 2 of this form.
- Use a known weight to determine the *Testing Load Radius*.

### Test Procedure:

#### **Determine Area W1 Length**

1. With the crane extended to the *Testing Load Radius* over the rear of the truck, lift the load. Keep the load less than 4" off of the ground.
2. Rotate the load counterclockwise. Monitor all vehicle tires to ensure they remain in contact with the test surface.
3. When one of the vehicle's tires breaks contact with the ground, stop the rotation.
4. Use a protractor to determine this angle. Write this angle on the Stability Test Results as *Area Y*.
5. Keeping the load off of the ground, retract or elevate the boom until all tires are in contact with the test surface.
6. Continue rotating the load counterclockwise while monitoring all vehicle tires.
7. When one of the vehicle's tires breaks contact with the ground, stop the rotation.
8. Keeping the load off of the ground, retract or elevate the boom until all tires are in contact with the test surface.
9. Repeat this procedure until either the vehicle prevents further rotation or a 180 degree rotation of the load is reached.
10. Record the load radius in feet at this point on the Stability Test Results as *Area W1 Length*.

#### **Determine Area W2 Length**

11. Return the load to the rear of the vehicle and extend the load to the *Testing Load Radius*. Keep the load less than 4" off of the ground.
12. Rotate the load clockwise. Monitor all vehicle tires to ensure they remain in contact with the test surface.
13. When one of the vehicle's tires breaks contact with the ground, stop the rotation.
14. Use a protractor to determine this angle and write this angle on the Stability Test Results as *Area Z*.
15. Keeping the load off of the ground, retract or elevate the boom until all tires are in contact with the test surface.
16. Continue rotating the load clockwise while monitoring all vehicle tires.
17. When one of the vehicle's tires breaks contact with the ground, stop the rotation.
18. Keeping the load off of the ground, retract or elevate the boom until all tires are in contact with the test surface.
19. Repeat this procedure until either the vehicle prevents further rotation or a 180 degree rotation of the load is reached.
20. Record the load radius in feet at this point on the Stability Test Results as *Area W2 Length*.

#### **Record Stability Test Results on Placard**

21. Record the information from the Stability Test Results on the CRANE TRUCK STABILITY plate (P.N. 18600) and install the plate in a visible position on the vehicle, preferably near the crane.

**THIS TEST IS NOW COMPLETE**

1-8

## STABILITY TEST FORM

Operational limits of this vehicle

VEHICLE INFORMATION	CRANE INFORMATION
Year _____	Model _____
Make _____	Serial Number _____
Model _____	Moment Rating (ft-lbs.) _____
VIN _____	

Determine The **Testing Load Radius** by using the following:

Moment Rating (ft-lbs.) \_\_\_\_\_  
 Multiply by 1.18 x \_\_\_\_\_  
 Divide by known weight ÷ \_\_\_\_\_  
**Testing Load Radius** (ft.) = \_\_\_\_\_

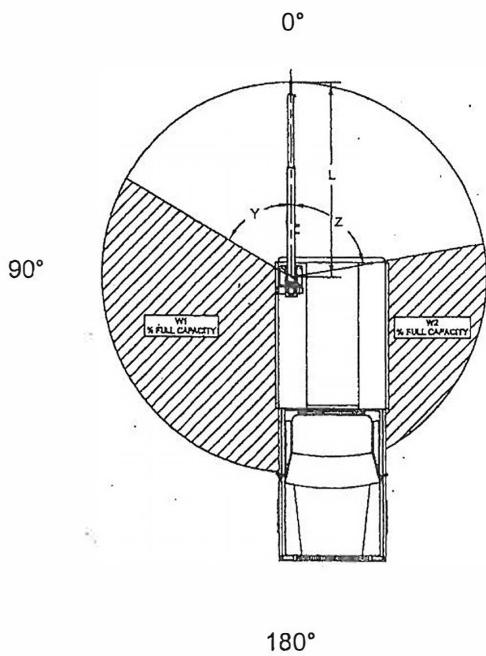

**Area W1 Length** \_\_\_\_\_  
**Testing Load Radius** (ft.) ÷ \_\_\_\_\_  
 Multiply by 100 x \_\_\_\_\_  
 W1 % Rated Capacity = \_\_\_\_\_

**Area W2 Length** \_\_\_\_\_  
**Testing Load Radius** (ft.) ÷ \_\_\_\_\_  
 Multiply by 100 x \_\_\_\_\_  
 W2 % Rated Capacity = \_\_\_\_\_

STABILITY TEST RESULTS	
Area Y:	_____ Degrees
Area Z:	_____ Degrees
Area W1 Rated Capacity:	_____ %
Area W2 Rated Capacity:	_____ %

Test performed by: \_\_\_\_\_

Date: \_\_\_\_\_

## CRANE SAFETY RULES

### CAUTION!

1. READ AND UNDERSTAND OPERATOR'S MANUAL.
2. INSPECT VEHICLE AND CRANE, INCLUDING ITS OPERATION BEFORE DAILY USE.
3. USE THIS EQUIPMENT ONLY ON SOLID LEVEL GROUND WITH OUTRIGGERS OR JACKSTANDS PROPERLY SET.
4. BEFORE OPERATING THE CRANE REFER TO MAXIMUM LOAD CHART ON CRANE FOR OPERATING LOAD LIMITS.
5. BE SURE LOAD BEING LIFTED IS WITHIN SAFE WINCH CAPACITY AS WELL AS SAFE CRANE CAPACITY. MULTI-PART LINE OPERATION IS REQUIRED WHEN SINGLE LINE LOAD CAPACITY OF WINCH IS EXCEEDED.
6. DO NOT OPERATE, WALK, OR STAND UNDER THE BOOM OR ANY SUSPENDED LOAD.
7. ALWAYS PAY OUT LOAD LINE BEFORE EXTENDING BOOM. WIRE ROPE DAMAGE AND / OR BREAKAGE MAY OCCUR.
8. BOOM MUST BE IN ITS REST BEFORE MOVING VEHICLE.
9. BOOM TIP MUST BE DIRECTLY OVER THE LOAD BEFORE ANY LIFTING IS STARTED. DO NOT DRAG LOADS WITH THIS CRANE.
10. MAINTAIN THIS CRANE AS REQUIRED IN THE OWNER'S MANUAL.
11. DO NOT ALLOW PERSONNEL TO RIDE ON THE LOAD LINE, LOAD, OR BOOM OF THIS CRANE.
12. IT IS UNLAWFUL TO OPERATE THIS EQUIPMENT WITHIN TEN FEET OF HIGH VOLTAGE LINE



THIS PAGE INTENTIONALLY LEFT BLANK



F1122-B  
05/12/08

HOUSTON, TEXAS  
FAX: (800) 824-5559 (USA & Canada)  
FAX: (713) 688-6324  
PHONE: (713) 688-5533  
[www.liftmore.com](http://www.liftmore.com)

## INTRODUCTION

This crane is a powerful machine designed to lift and move heavy loads. There are many hazards associated with these operations. Liftmoore has designed this crane to be as safe as possible but -

**IT IS THE OPERATOR'S RESPONSIBILITY TO PREVENT ACCIDENTS!**

This takes pre-planning, attention, and knowledge of basic principles and rules. Even if you have used similar cranes, reading this manual in its entirety will help prevent damage, injury, or even loss of life; benefits well worth the short amount of time it takes to read these pages.

### REGULATORY AUTHORITY

Use of this crane is governed by OSHA 29 CFR 1910.180 and may be governed by other federal, state, or local regulations.

**IT IS THE OPERATOR'S RESPONSIBILITY TO UNDERSTAND AND COMPLY WITH ALL APPLICABLE REGULATIONS GOVERNING THE OPERATION, INSPECTION, AND MAINTENANCE OF THIS CRANE.**

Personnel should be trained, tested, and certified, as recommended by OSHA and ANSI standards, before operating this crane.

### USING THIS MANUAL

This manual assumes that the crane is mounted on a typical service body type or similar truck, which is powered by the vehicle electrical or hydraulic system, and is controlled by either the standard pendant control or FM radio control sold by Liftmoore, Inc.

This manual is supplied to provide basic guidelines for the safe use, routine maintenance, and general inspections of this crane.

This manual is supplied to provide basic guidelines for the safe use, routine maintenance, and general inspections of this crane.

Laws, regulations, standards, or policies may be more restrictive than this manual. If a conflict exists for any limit or condition, the safest or most prohibitive shall be used. Under no circumstances shall the load, moment, or stability ratings be exceeded.

Pay particular attention to the following:

**WARNING!** – Draws attention to hazards, conditions, or procedures that if not observed could result in injury or death.

**CAUTION!** – Draws attention to hazards, conditions, or procedures that if not observed could result in damage to the crane, load, or other equipment. Equipment failure could in turn lead to injury or death.

**NOTE!** – Draws attention to conditions or procedures that are essential to emphasize.

For questions, interpretations, or to report errors, please contact Liftmoore, Inc, Engineering Dept.



## OPERATING PRACTICES

### OPERATING RESTRICTIONS

#### DUTY CYCLE

For Electric Cranes the duty cycle time should be limited to 10%. This is limited by heat buildup in the motors and declining charge in the batteries. (Installing extra batteries near the crane helps keep the voltage at maximum.)

#### PERSONNEL

LIFTING OR MOVING OF PERSONNEL IS STRICTLY PROHIBITED! This crane was neither designed nor intended to lift personnel. Under no circumstances should anyone be allowed to ride on the crane, line, or load. All non-essential personnel must be kept away when using the crane. The load must never be moved over people, nor must anyone be allowed to pass or stand under a suspended load.

#### ELECTRICAL LINES

Consult ANSI B30.5 for operating procedures, minimum safe distances, and prohibited zones when working around electrical lines or poles.

When operating near electrical power lines, the crane must be positioned so that the distance from the crane to the lines or poles is equal to or greater than the length of the fully extended boom plus the minimum safe distance required.

All parts of the crane, line, and load must be kept a minimum safe distance from electrical power lines and poles. This distance is 10 feet for electrical lines carrying 50kV or less.

UNDER NO CIRCUMSTANCES SHOULD A CRANE BE OPERATED UNDER ELECTRICAL POWER LINES.

#### SETUP

**POSITION** The vehicle must be positioned so that the load is kept as close to the crane base as possible to reduce the moment on the crane. Consideration must be given to starting and ending position as well as firmness and slope of the ground and any obstructions.

**OUTRIGGERS** The outriggers or jack-stands must be firmly set and the vehicle as level as possible. This will reduce the stresses on the rotation drive and keep the load off the vehicle's suspension. Keep in mind that the weight on the vehicle will shift as the crane and load is rotated.

**MANUAL BOOM EXTENSION** If the manual extension part of the boom is needed, it must be extended and the boom pin placed in the required position. Insert the pin and replace the pin's hairpin keeper before attempting to lift any load.

**LOAD LIMIT** The operator must understand the crane load chart. The operator must ensure that the load is within the load limits over the entire range which it will be moved. Be sure to include the weight of any lifting devices including the travel block.

The load limit chart is attached to the side of the crane to aid the operator.

The boom angle indicator and chart aids the operator in determining the load capacity at various boom angles and extensions. It also gives the load limit at that configuration.

**STABILITY** A stability chart must be posted near the crane. The operator must understand the stability chart. The crane may be de-rated over some areas of its operating radius.



**TRAVEL BLOCK** The operator must determine if the load is within the single line compatibility of the winch or if a multi-part line configuration is needed.

**REEVING** Ensure the proper routing of the rope through the sheaves and travel block. The rope must lie in the sheave groove and must not rub against any metal objects.

Ensure the rope is correctly wound on the winch drum. The crane assembly drawing will indicate if the rope must be wound over the top or bottom of the drum. The rope must never contact any part of the winch mounting.

### **WARNING!**

If the winch winding direction is reversed the brake will not work and the load will fall.

### **CRANE POWER**

Before operating the crane turn ON power switch (Normally located under the crane) and twist to release E-Stop switch.

Push in E-Stop switch to turn OFF when the crane is no longer in use. Twist to release, hydraulic will not function if E-Stop button is pushed in.

### **ATTACHING THE LOAD**

**POSITION** The boom tip must be moved over the load before lifting so that it will be lifted straight up.

### **CAUTION!**

Never drag a load with the crane. Dragging a load puts very high stresses on the crane for which it was not designed.

**ROPE** Check the rope condition to ensure it is not frayed or damaged. Ensure that the rope is not kinked and that it does not contact any sharp edges or make any sharp bends.

If using double line configuration, ensure that the lines are not twisted.

### **CAUTION!**

Never wrap the hoist rope around the load! Serious damage to the rope WILL occur.

**HOOK** Always make sure the load is applied to the throat of the hook. Never use a bent hook.

### **CAUTION!**

Always lift with the throat of the hook. Never lift with the load applied to the tip of the hook. Doing so will bend the hook.

**SLINGS** If the load does not have a lifting eye, use a nylon, chain, or other type of sling designed for lifting and rated for loads greater than that being lifted.

**BALANCE** Ensure the load will be secure and balanced when lifted. Ensure that the load cannot shift in the sling and that the sling cannot slide across the hook should the load become unbalanced.



**1-14**

### **LIFTING THE LOAD**

Before lifting, ensure that the load is free from all mountings and is no way attached or stuck to anything.

Ensure that at least five full wraps remain on the winch drum at all times.

Test the winch brake by lifting the load a few inches and ensuring that it does not slip.

### **HOLDING THE LOAD**

The operator must keep the load in sight at all times once it is lifted.

The operator must never leave the controls once the load is lifted.

The operator must ensure that no one is allowed to pass or stand under a suspended load.

### **CAUTION!**

Never move the vehicle with a suspended load. Doing so will put dynamic loads on the crane for which it was not designed.

### **MOVING THE LOAD**

Before moving the load, make sure the path is free of any obstructions or people.

Avoid sudden accelerations or stops. Speeds must be kept to a minimum, especially rotation, to keep the load from swinging.

Avoid sudden reversing of direction. Do not reverse direction while the load is still moving.

Make sure that no part of the crane, boom, or load makes contact with any obstruction or comes within a minimum of ten feet from any electrical line.

### **TRANSIT**

While in transit, the crane must be stowed, preferably in a boom rest. The crane must be prevented from rotating and the hook prevented from swinging.





## INSPECTION AND MAINTENANCE

OSHA and ANSI require frequent and periodic inspections. Records of these inspections must be kept readily available. Liftmoore requires periodic maintenance to ensure proper operation and prolonged life of the crane.

### INSPECTION

#### DAILY INSPECTION

OSHA 29CFR 1910.180 (d)(2)(i) requires the following be checked daily prior to use:

- All control mechanisms for maladjustment interfering with proper operation as well as for excessive wear of components and contamination by lubricants or other foreign matter.
- All safety devices for malfunction. This should include the anti-two block and pressure switch.
- Deterioration or leakage in air or hydraulic systems.
- Crane hooks with deformations or cracks. For hooks with cracks or having more than 15 percent in excess of normal throat opening or more than 10 deg. twist from the plane of the unbent hook.
- Electrical apparatus for malfunctioning, signs of excessive deterioration, dirt, and moisture accumulation. This should include the battery terminals, master disconnect switch, electrical swivel
- The wire rope shall be replaced if any of the following conditions are noted:
  - Kinking, crushing, bird-caging, or other damage
  - Reductions from nominal diameter of more than one-sixty-fourth inch for diameters up to and including five-sixteenths inch, one-thirty-second inch for diameters three-eighths inch to and including one-half inch.
  - Thimble is not in place or is damaged
  - Any evidence of heat damage
  - Six or more randomly distributed broken wires in 1 lay
  - Three or more broken wires in 1 strand in 1 lay

### MONTHLY INSPECTION

A thorough inspection of all ropes in use shall be made at least once a month and a certification record which includes the date of inspection, the signature of the person who performed the inspection and an identifier for the ropes shall be prepared and kept on file where readily available. All inspections shall be performed by an appointed or authorized person. Any deterioration, resulting in appreciable loss of original strength shall be carefully observed and determination made as to whether further use of the rope would constitute a safety hazard. Some of the conditions that could result in an appreciable loss of strength are the following:

- Reduction of rope diameter below nominal diameter due to loss of core support, internal or external corrosion, or wear of outside wires.
- A number of broken outside wires and the degree of distribution of concentration of such broken wires.



- Worn outside wires.
- Corroded or broken wires at end connections.
- Corroded, cracked, bent, worn, or improperly applied end connections.
- Severe kinking, crushing, cutting, or unstranding.

#### PERIODIC INSPECTION

An Annual Inspection Form is included in this manual. OSHA 29CFR 1910.180 (d)(2)ii) requires periodic inspections of this crane. Liftmoore recommends an annual inspection using the included form.

#### MAINTENANCE PRECAUTIONS

The crane should be maintained monthly for safety reasons and to reduce stress on the crane.

#### WARNING!

Never perform any maintenance while the crane has any type of load on it. Use the manual operation procedure to lower the load if necessary.

#### WARNING!

Hydraulic cylinders may have high pressure stored in them even after hydraulic power is removed.

The counterbalance and pilot operated check valve in the cylinder will always hold some pressure in the cylinder. Slightly extending the cylinder then retracting a small amount will relieve most of the pressure in the cylinder. **DO NOT DEADHEAD THE CYLINDER!** This will store the maximum amount of pressure in the cylinder. Care should be taken when either valve is removed from the cylinder as some pressure will still remain.

After any maintenance has been performed the crane shall not be operated until all guards have been reinstalled, all safety

devices reactivated, and maintenance equipment removed.

**LUBRICATION** Refer to the crane specification section for the periodic maintenance schedule and type of lubrication required.

**BOLTS** Bolts may loosen over time due to vibration; therefore they should be checked periodically. If bolts need to be replaced, make sure they are replaced with bolts of equal or greater strength. Check the periodic maintenance schedule (Crane Specification Section) for bolt specification and torque.

#### NOTE!

Sheave and boom and cylinder pivot bolts are not standard bolts. The shank and thread length of these bolts have been modified so that they do not pivot on the threads. Consult the parts section of this manual for part numbers of these bolts.

#### OTHER MAINTENANCE

Refer to parts drawings for any specific maintenance or adjustment procedures such as hydraulic winch brake, rotation drive gear set adjustment, Ect.



## MONTHLY INSPECTION REPORT

**Crane Model No.** \_\_\_\_\_ **Serial Number** \_\_\_\_\_

Are Boom Hitch Pins and Keepers in place?	Yes _____	No _____
Wire Line Hook with Safety Latch Working?	Yes _____	No _____
Is Hook OK, (Not bent)?	Yes _____	No _____
Is Thimble on Wire Rope OK?	Yes _____	No _____
Is Traveling Block in use?	Yes _____	No _____
Is Wire Rope OK, not kinked or frayed?	Yes _____	No _____
Are all Boom Sections straight?	Yes _____	No _____
Are Sheave Bolts in place and tight?	Yes _____	No _____
Do all Sheaves rotate easily?	Yes _____	No _____
Are Mounting Bolts tight?	Yes _____	No _____
Is Anti Two-Block functioning properly?	Yes _____	No _____
Is Boom Angle Indicator in place and functioning and is Chart legible?	Yes _____	No _____
Are Cylinder Mounting Bolts secure?	Yes _____	No _____
Are Winch Mounting Bolts tight?	Yes _____	No _____
When stopped does winch drift less than 1.0 Inches?	Yes _____	No _____
Is Load Chart in place and easily read?	Yes _____	No _____
Are functions on Pendant operating correctly?	Yes _____	No _____
Is Hydraulic Reservoir full?	Yes _____	No _____
Is Outrigger straight and functioning?	Yes _____	No _____

Any items checked 'No' must be repaired before using this crane.



ANNUAL CRANE CERTIFICATION (29CFR1910.180)

OWNER \_\_\_\_\_

MODEL NUMBER \_\_\_\_\_ SERIAL NUMBER \_\_\_\_\_

DATE \_\_\_\_\_

Check the following:

\_\_\_ Crane Mounting Bolts (Torque)

\_\_\_ Winch mounting Bolts (Torque)

\_\_\_ Boom mounting bolts

\_\_\_ Cylinder mounting bolts

\_\_\_ Cracks on boom (Check when extended)

\_\_\_ Extension Pads not worn excessively

\_\_\_ Cracks on housing

\_\_\_ Weld cracks on boom

\_\_\_ Weld cracks on housing

\_\_\_ Boom swing approximately one inch or less at boom tip when retracted

\_\_\_ Hydraulic leaks

\_\_\_ Hoses not chafed or cracked

Sheaves not cracked

\_\_\_ Boom Tip

\_\_\_ Traveling Block

\_\_\_ Sheaves not worn excessively

\_\_\_ Boom Tip

\_\_\_ Traveling Block

\_\_\_ Sheaves rotate freely

\_\_\_ Boom Tip

\_\_\_ Traveling Block

\_\_\_ *Load Chart in place and legible*

\_\_\_ *Boom angle chart in place and legible*

\_\_\_ *Labels in place (See manufacturer's chart)*

\_\_\_ *Crane Hook Throat Opening within 15% of standard*

\_\_\_ *Crane Hook not bent more than 10 degrees from plane*

\_\_\_ *Hook safety latch operating properly*

\_\_\_ *Booms pin(s) and Keeper(s) in place (Manual Extension Section)*

\_\_\_ *Wire Rope removed if the following occurs:*

*Six randomly distributed broken wires in one lay or three broken wires in one strand in one lay.*

*Wear of one-third the original diameter of outside individual wires.*

*Kinking, crushing, bird-caging or any other damage.*

*Evidence of heat damage.*

*Reduction from nominal diameter of more than one sixty-fourth inch for diameters to five-sixteenths diameter and one-thirty-second inch for diameters three-eighths to one-half inch.*

\_\_\_ *Wire Line installed as manufacturer requires.*

\_\_\_ *Protective covers in place*

\_\_\_ *Grease crane as required*

*Check fluid level*

\_\_\_ *Winch*

\_\_\_ *Gearbox*

\_\_\_ *Reservoir*

*Control system for proper operation*

\_\_\_ *Winch Up and Down*

\_\_\_ *Boom Up and Down*

\_\_\_ *Boom In and Out*

\_\_\_ *Rotation CW and CCW*

*Anti Two-Block (Required on Power Extendible Cranes) interrupts:*

\_\_\_ *Boom Down*

\_\_\_ *Boom Out*

\_\_\_ *Winch Up*

\_\_\_ *Boom Up stopped by Up Limit Switch*

\_\_\_ *Outrigger or jackstand operable*

\_\_\_ *Outrigger crushing decal in place*

\_\_\_ *Outrigger and Jackstand operates properly*

\_\_\_ *Boom rest in place and used*

\_\_\_ *Load Sensor trips when overloaded*

\_\_\_ *Winch Down does not overrun when stopped*

\_\_\_ *Crane stability chart in place and visible.*

*I certify that I have performed the above tests and that any deficiencies were corrected and now comply as above.*

*Signed* \_\_\_\_\_



*Print Name* \_\_\_\_\_

*Company* \_\_\_\_\_

*Address* \_\_\_\_\_



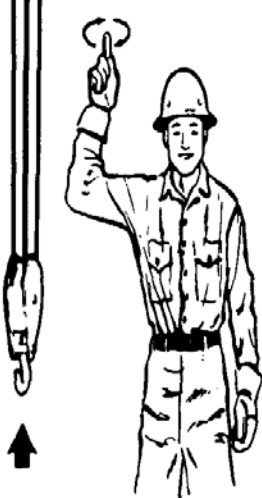
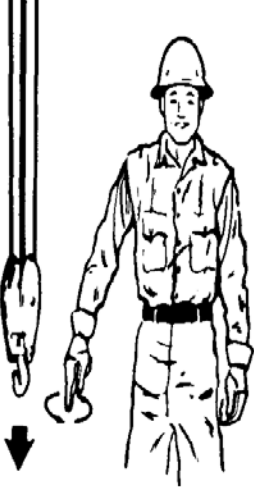

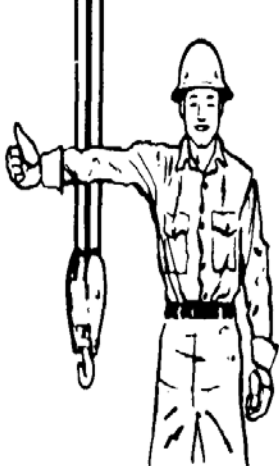
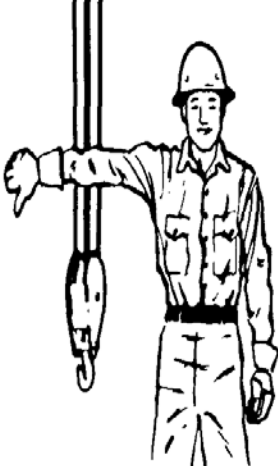

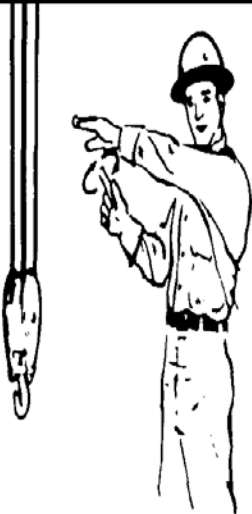
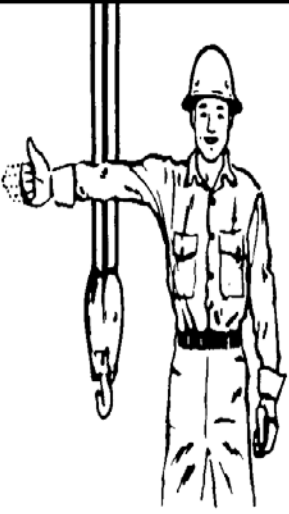
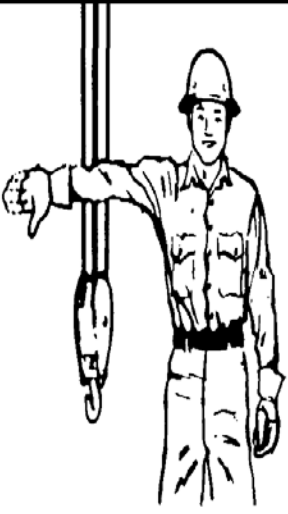
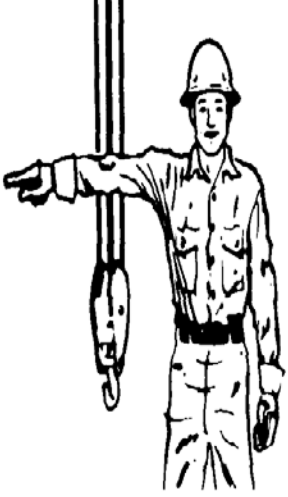
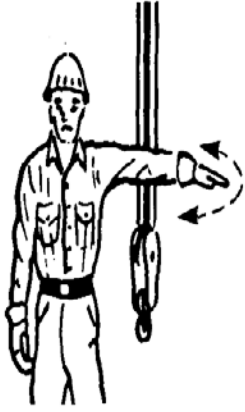
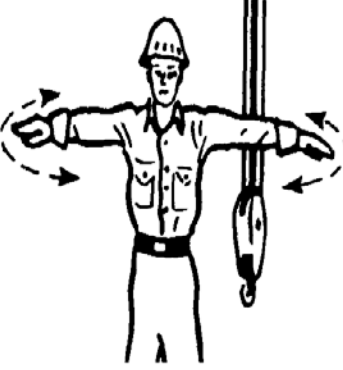

*City* \_\_\_\_\_ *State* \_\_\_\_\_

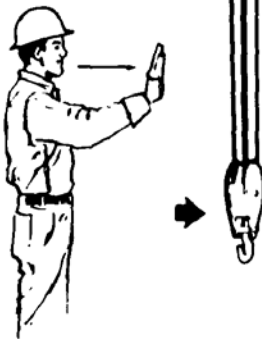
**STANDARD HAND SIGNALS FOR CONTROLLING CRANE OPERATIONS**

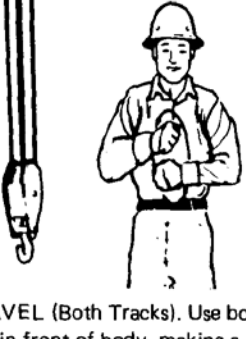
 <p><b>HOIST.</b> With forearm vertical, forefinger pointing up, move hand in small horizontal circle.</p>	 <p><b>LOWER.</b> With arm extended downward, forefinger pointing down, move hand in small horizontal circle.</p>	 <p><b>USE MAIN HOIST.</b> Tap fist on head; then use regular signals.</p>
 <p><b>USE WHIPLINE (Auxiliary Hoist).</b> Tap elbow with one hand; then use regular signals.</p>	 <p><b>RAISE BOOM.</b> Arm extended, fingers closed, thumb pointing upward.</p>	 <p><b>LOWER BOOM.</b> Arm extended, fingers closed, thumb pointing downward.</p>

 <p data-bbox="256 751 597 934"><b>MOVE SLOWLY.</b> Use one hand to give any motion signal and place other hand motionless in front of hand giving the motion signal. (Hoist slowly shown as example.)</p>	 <p data-bbox="630 751 971 898"><b>RAISE THE BOOM AND LOWER THE LOAD.</b> With arm extended, thumb pointing up, flex fingers in and out as long as load movement is desired.</p>	 <p data-bbox="1003 751 1344 934"><b>LOWER THE BOOM AND RAISE THE LOAD.</b> With arm extended, thumb pointing down, flex fingers in and out as long as load movement is desired.</p>
 <p data-bbox="264 1497 597 1570"><b>SWING.</b> Arm extended, point with finger in direction of swing of boom.</p>	 <p data-bbox="638 1497 971 1612"><b>STOP.</b> Arm extended, palm down, move arm back and forth horizontally.</p>	 <p data-bbox="995 1497 1328 1612"><b>EMERGENCY STOP.</b> Both arms extended, palms down, move arms back and forth horizontally.</p>



 <p><b>TRAVEL.</b> Arm extended forward, hand open and slightly raised, make pushing motion in direction of travel.</p>	 <p><b>DOG EVERYTHING.</b> Clasp hands in front of body.</p>	 <p><b>TRAVEL (Both Tracks).</b> Use both fists in front of body, making a circular motion about each other, indicating direction of travel, forward or backward. (For land cranes only.)</p>
 <p><b>TRAVEL. (One Track)</b> Lock the track on side indicated by raised fist. Travel opposite track in direction indicated by circular motion of other fist, rotated vertically in front of body. (For land cranes only.)</p>	 <p><b>EXTEND BOOM (Telescoping Booms).</b> Both fists in front of body with thumbs pointing outward.</p>	 <p><b>RETRACT BOOM (Telescoping Booms).</b> Both fists in front of body with thumbs pointing toward each other.</p>
 <p><b>EXTEND BOOM (Telescoping Boom).</b> One Hand Signal. One fist in front of chest with thumb tapping chest.</p>		 <p><b>RETRACT BOOM (Telescoping Boom).</b> One Hand Signal. One fist in front of chest, thumb pointing outward and heel of fist tapping chest.</p>

THIS PAGE INTENTIONALLY LEFT BLANK



F2409-0  
4/11/16

HOUSTON, TEXAS  
FAX: (800) 824-5559 (USA & Canada)  
FAX: (713) 688-6324  
PHONE: (713) 688-5533  
[www.liftmoore.com](http://www.liftmoore.com)

## PROPORTIONAL PENDANT CONTROL SYSTEM

### (WIRED OR FM)

Liftmoore cranes are electrically controlled using the hand-held pendant, which works in conjunction with the crane control module to operate powered functions and precisely regulate speed.

### PENDANT - WIRED

All user inputs are facilitated by a remote pendant control. The pendant consists of pistol grip housing, wire, and control plug. The control plug mates with the crane control socket. The control socket is mounted on the cranes housing.

The pistol grip housing contains an on/off switch, one momentary contact switch for each function, and a trigger for regulating speed.

### RELAY BOX ASSEMBLY (22569)

The crane control module contains the proportional valve driver and the limiting system control. It consists of a single printed circuit board enclosed in a rugged, sealed housing. Status LEDs are located on the circuit board to aid in troubleshooting.

The proportional valve driver supplies a regulated voltage to the pendant trigger, interprets the signal returned from the trigger, and then outputs an appropriate signal to the proportional valve.

The limiting system control is part of the safety system. Refer to that section for more information.

## OPERATION

Plug the pendant into the crane control socket. Ensure all pins are straight and free of dirt, moisture, and corrosion. Turn the locking ring approximately 1/3 turn until it clicks into the locked position.

Turn the pendant control on. (TWIST & RELEASE E-STOP BUTTON)

Select the function switch and direction as indicated on the label for the desired operation.

### WARNING!

Never pull the trigger before operating the selection switch. Doing so will cause sudden acceleration and uncontrolled motion of the load.

SLOWLY squeeze the trigger until the desired speed is reached. Do not operate the function any faster than necessary. Be especially careful when rotating loads to prevent swinging.

When stopping, slowly release the trigger before releasing the function switch.

## CARE AND MAINTENANCE

The pendant control is designed to be as rugged and maintenance free as possible; however, care should be used in handling and storage as it is expensive to replace.

Follow these simple practices:

- Keep the pendant out of the weather
- When not in use, store the pendant inside the vehicle
- Do not wrap the wire too tightly as internal damage to the wires may result
- Do not place sharp or heavy object on the cord

### NOTE!

The pendant is designed to be weatherproof not waterproof. It may be used in inclement weather, but if left outside or where water can puddle, water can seep inside.

Maintenance should be limited to routine inspection of the plug, wire, and fasteners.



## SAFETY SYSTEM

The safety system is designed to help prevent damage to the crane that would be caused by overload or two-blocking. The system consists of a load sensor, anti-two block device (optional on smaller, electric cranes), and limiting system control board.

When the applicable switch detects an overloading or two-block condition, the limiting system will prevent activation of winch up, and extend out since these directions would cause damage. Winch down, boom down, boom up, extend in, and power rotation will still function so that the crane can be moved to a safe configuration.

### CAUTION!

Never de-activate or override safety functions. Doing so can result in serious damage to the crane and possibly injury or death.

### LOAD SENSOR

A pressure activated switch in the elevation cylinder acts as a load sensor. This switch is normally closed and opens at the preset pressure corresponding to the load rating of the crane.

### CAUTION!

The load sensor will not function when the elevation cylinder is fully retracted and is inaccurate when the boom is below horizontal.

### CAUTION!

The operator must never rely strictly on the load sensor to determine overload conditions. The load and load limits must always be known and adhered to.

### ANTI-TWO BLOCK

The anti-two block device (optional on smaller electric cranes), mounted on the boom crown plate, consists of a normally open switch actuated by a lever. A weight is attached to the lever and holds the switch

closed. If the weight is lifted by the hook or travel block the switch opens.

The power and signal wires are wired through the cord reel, which is in turn wired to the ATB switch.

## LIMITING SYSTEM CONTROL

Two systems are included to limit crane overloads and wire rope breakage. When a crane overload occurs, the load sensor will stop winch up, extension out and boom down. To prevent breaking the wire rope, the Anti Two-Block device stops winch up and extension out when either is engaged.

The capacity of boom up is limited by the pressure setting of the relief valve in the manifold.

There is a one second delay before the deactivation of boom down when the load sensor is tripped to prevent false readings caused by pressure spikes.

## MISCELLANEOUS

### UP LIMIT SWITCH

The up limit switch prevents the elevation cylinder from reaching full extension. If the elevation cylinder were to "dead-head", the resulting pressure would activate the load sensor, preventing boom down. The boom would then have to be lowered using the manual operation buttons on the solenoid valves.

### CIRCUIT BREAKER, FUSE

For electric cranes a 150 Amp circuit breaker is supplied with the crane. It should be installed as close to the battery as possible. For hydraulic cranes a 10 Amp blade type fuse is supplied.

### DISCONNECT SWITCH

A power disconnect switch is supplied with the crane. Power to the crane should be turned off whenever not in use. This is to prevent inadvertent or unauthorized use and will help prevent corrosion at electrical connections.



## HYDRAULIC SYSTEM

Integrated Hyd Proportional

The hydraulic system consists of the hydraulic swivel, manifold with solenoid valves, cylinders, motors, and tubing and hoses. Hydraulic power is received from an external hydraulic source, typically a PTO driven pump attached to the vehicle transmission. The hydraulic system uses open center valves in series so that multiple functions can be operated simultaneously.

### SWIVEL- (NOT USED IN 1032 OR 1640)

The hydraulic swivel is a two-port swivel that allows continuous, unlimited rotation. Refer to drawing for more information.

### MANIFOLD

The hydraulic manifold consists of a differential pressure sensing flow control valve, the system relief valve, proportional flow control valve, and 4 way directional control valves.

The Logic valve is a pilot operated pressure compensated flow control cartridge valve. It supplies the required flow to the manifold and returns excess flow to the tank so that pressure drop and heat build up are minimized.

The system relief valve prevents damage that would be caused by excessive pressure in the system. It is a cartridge type valve. Factory setting is 2800PSI.

The proportional valve is an electrically operated flow control valve. It allows the operator to control the flow, and therefore the speed, of the selected functions. The flow output is directly proportional to the electrical input. The valve may be operated manually by depressing the manual operation button on the top of the valve.

Each hydraulically operated function is controlled by a 4 way, 3 position open center solenoid valve. It is electrically operated and spring biased to center. A manual operation button is incorporated in the coil retaining nut.

Each hydraulically operated function is controlled by a 4 way, 3 position open center solenoid valve. It is electrically operated and spring biased to center. A manual operation button is incorporated in the coil retaining nut.

## CYLINDERS

Hydraulic cylinders are double acting cylinders with integrally mounted counterbalance valve and pilot operated check valves. Refer to the cylinder drawings for specific information.

All cylinders use a counter-balance load holding cartridge valve on the extend port. This valve performs 3 functions:

- Controls the rate of decent when lowering the load
- Keeps load from falling in the event of sudden loss of system pressure, such as when a hose bursts.
- Acts as a relief valve to prevent damage from induced load or thermal expansion.

It allows free flow to extend then blocks flow until opened by pilot pressure to the retract port or when the relief pressure is reached.

Some cylinders utilize a pilot operated check valve on the retract port to prevent the cylinder from creeping out under no load conditions. This valve allows flow into, but prevents flow from the retract port, thus hydraulically locking the cylinder until opened by pilot pressure to the extend port.

## MOTORS

The hydraulic motors used by the rotation drive and hydraulic winch are high torque, low speed constant displacement motor.



## MANUAL OPERATION

If electrical problems occur the solenoid valves may be operated manually. Refer to the manifold drawing for function valves and directions.

Directional control valves are manually operated by depressing the boot at the end of the valve. Use a blunt object (e.g. bolt or screwdriver handle) to assist in the operation.

Proportional valves are operated with either a boot or a small screw. Depress the boot or turn the screw slowly while operating a function to determine optimum speed. Turning the screw all the way in will result in rapid crane movement.

If hydraulic power is lost while a load is suspended, the load may be lowered by decreasing the setting on the counterbalance valve. This should only be done in extreme cases. The valve must be reset before the crane is returned to use.

To decrease the setting, loosen the locknut on the valve, then slowly turn the adjustment stem **CLOCKWISE** until the load begins to lower. Count the number of turns so that the valve can be returned to its original setting.

Alternately, a pressure gage must be put on the retract port to adjust the setting so that approx. 1800 PSI is required to lower the boom with no load.

Test the setting by lifting a known load near the moment rating of the crane.



## BASIC TROUBLESHOOTING

The following chart gives a quick reference to help identify and correct problems. Refer to the following pages for more detailed information.

PROBLEM	PROBABLE CAUSE	CORRECTIVE ACTION
NO FUNCTIONS WORK	<p>Not receiving electrical power</p>   <p>Not receiving hydraulic power</p>   <p>Control problem</p>	<p>Check all connections Check all fuses and circuit breakers Check for electrical power at first electrical connection and trace back to crane</p>   <p>Check flow from pump Deadhead cylinder and check pressure at pump</p>   <p>See control section</p>
<p>FUNCTION NOT WORKING</p>   <p style="text-align: center;">winch up, extension out not working</p>      <p style="text-align: center;">Boom down, winch down, extension in not working</p>      <p style="text-align: center;">Other function not working</p>	<p>No signal from ATB or Load sensor (switch tripped, bad switch, bad wiring or not receiving power)</p>   <p>Relay card malfunction</p>   <p>Not receiving enough pressure</p>      <p>Faulty wiring</p>   <p>Valve coils bad</p>	<p>Check input signal to relay board if no signal, trace back to switch</p>   <p>Check LEDs on board for error codes and outputs</p>   <p>Deadhead cylinder and check pressure at pump Check differential pressure valve for contamination Check relief valve for proper setting and possible contamination</p>   <p>Check all wiring for breaks or shorts Check all ground wires for good connection</p>   <p>Check coil resistance</p>
<p>ALL FUNCTIONS SLOW</p>   <p>* These items only apply to cranes with proportional control systems.</p>	<p>Not receiving enough flow</p>   <p>Low battery voltage Check with engine running</p>   <p>* Proportional valve problem</p>      <p>* Control problem</p>	<p>Check fluid levels Check all filters and any other restrictions</p>   <p>Charge battery (BATTERY MAY BE BAD)</p>   <p>Try manual operation of proportional valve</p>   <p>Check voltage at valve for approx. at min and max(see troubleshooting form for specific valves)</p>   <p>See control section</p>



## CONTROL TROUBLESHOOTING CHART

### WIRE PENDANT

No functions working	Not receiving power	Check crane control socket Pin E ensure that it is receiving 12V  With the plug disconnected, activate a function switch then check continuity between Pin E and the activated function/direction pin  For example: activate Hoist Down and check for continuity between Pin E and Pin P
One function not working	Faulty wiring/switch malfunction	With the plug disconnected, activate the function that is not working and check for continuity between Pin E and corresponding function pin
All functions slow  (APPLIES TO PROPORTIONAL CRANES ONLY)	Trigger problem	Check Crane RELAY BOX for Error Codes and Proportional Output Voltage
	Valve driver problem	Calibrate valve driver board

FIGURE

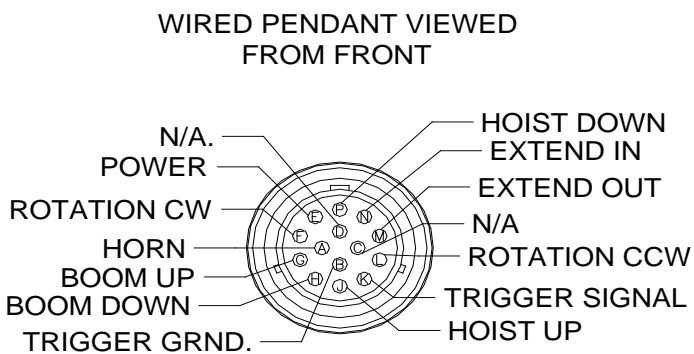

To Display an error code, the controller turns on and off the error code LED a certain number of times with a pause at the end. It repeats the code until the problem is resolved. The **Error Code Chart** is provided to assist the service personnel in troubleshooting the system.

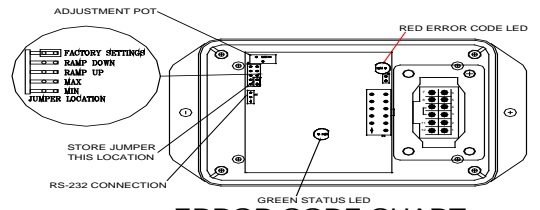

ERROR CODE CHART

ERROR CODE COUNT	PROBABLE CAUSE
1	No Input To ATB Switch Input
2	No Input To Pressure Switch Input Or Overload Condition
3	Short Or Overload To Winch Up Output
4	Short Or Overload To Elevation Down Output
5	Short Or Overload To Extension Out Output
6	Trigger Input Out Of Range

**Figure 1 RELAY BOX  
SEE DWG**

**Figure 2 CONTROL PLUG ON PENDANT 24694**





## TROUBLESHOOTING SAFETY SYSTEM

DTCH Relay Card

To check functions controlled by the safety system check the status indicators. (See Relay Box Assembly drawing.) If only one of the safety functions is not working, activate that function and check for error codes and/or its output status indicator.

For non-FM systems, if the status indicator lights then the problem is in the wiring or in the solenoid coil. If the light does not illuminate, check the control pendant. If the control pendant is good then the crane control module needs to be replaced.

For FM systems, check for error codes. If none are present, see the FM Troubleshooting section.

If boom out, boom down and winch up are not working, confirm that the control board has power. Confirm that the board is receiving a signal from the ATB and load sensor.

If the error code is active, ensure that the crane is not overloaded and that the ATB lever is holding the switch closed. Check for voltage at the ATB and Load Sensor inputs.

### CHECK LOAD SENSOR SWITCH

If the load sensor input is not receiving voltage, locate the load sensor connector inside the crane housing. The plug side will have a red wire and a gray wire, the receptacle side will have a red and a white wire.

Disconnect and check for continuity between the two pins on the receptacle (switch side). If there is no continuity then the load sensor is bad and needs to be replaced.

### CHECK ATB SWITCH

If the ATB input is not receiving voltage remove the ATB housing cover and disconnect the connector. Check for continuity on the switch side. Lifting the weight should break the continuity. If either of these conditions is incorrect the switch is bad and needs to be replaced.

### CHECK CORD REEL

Check the ATB switch if not done so already. Locate the ATB connector inside the crane housing. The plug side will have a red wire and a black wire. The receptacle side will have a white wire and a black wire.

Disconnect the plug going to the switch. Check for continuity between the two pins on the receptacle. Have someone lift the weight on the ATB and continuity should be broken. If either of these conditions are incorrect then the cord reel is bad and needs to be replaced.

### CHECK POWER TO SAFETY SWITCHES

If the safety switch is good, check for voltage at pin 1 (the red wire) on the plug. If there is no voltage, follow the wire back to the 6-pin power distribution plug, checking for breaks or shorts.

Remove the power distribution receptacle (cap).

#### **NOTE!**

Removing the cap will disconnect power to all electrical components. Be sure to replace the cap before continuing.

Check the cap for bent pins. Check that all wires are fully seated in the plug. If they are not, then remove the green locking wedge and push the wires forward until seated. Reinstall the wedge ensuring that no wires are pushed back.



## TROUBLESHOOTING THE PROPORTIONAL SYSTEM

21398 HALL EFFECT, 12V Diplomatic Coil

If no functions work or if all functions are slow when controlled by the pendant, but work correctly when the manual operation button is pressed on the proportional valve then the problem is with the proportional electronic control system.

### Proportional Valve Parameters

Cracking voltage	2.6V
Full open voltage	7.75V
Coil Resistance	3.66Ω

### CHECK VOLTAGE AT VALVE

Have the engine running to generate sufficient voltage (13-14V). As the trigger is pulled the valve voltage should start near zero, jump to the valve cracking voltage after slight trigger travel, increase steadily as the trigger is pulled, reaching the full open voltage.

If the voltages are correct, check the resistance across the coil. If the resistance differs significantly from the nominal resistance replace the coil.



## DEUTSCH CONNECTIONS & PINS



### FEMALE'S



### MALE'S

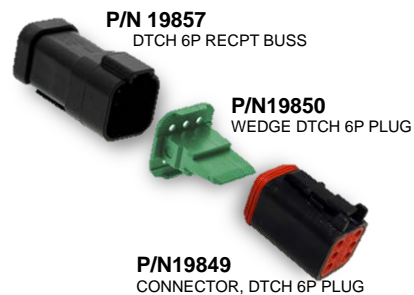
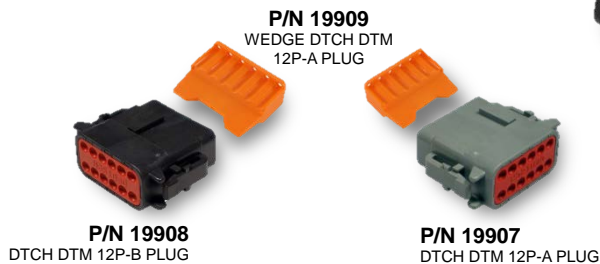
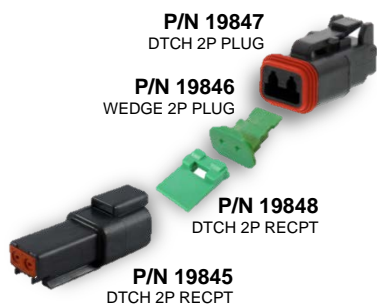

F2435-0  
06/16/16  
I:FORMS

HOUSTON, TEXAS  
FAX: (800) 824-5559 (USA & Canada)  
FAX: (713) 688-6324  
PHONE: (713) 688-5533  
www.liftmoore.com

THIS PAGE INTENTIONALLY LEFT BLANK

## SECTION 3 CRANE SPECIFICATIONS

### MODEL 3660 CRANES

MOMENT RATING                    36000 FT-LBS

MAX SINGLE LINE LOAD        3000 LBS

MAX DOUBLE LINE LOAD       6000 LBS

LIFTING CAPACITIES AT VARIOUS LOAD RADII

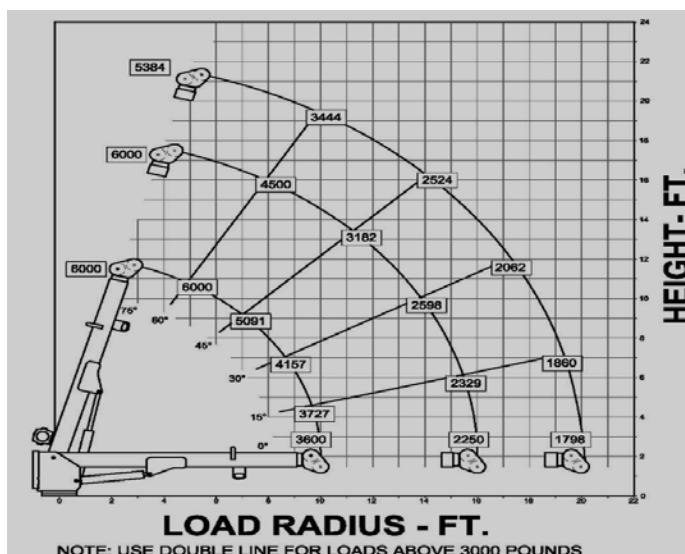

POWERED FUNCTIONS AND EXPECTED TIMES

WINCH	UP: 6.3 s	DOWN: 6 s	1 REVOLUTION
BOOM ELEVATION	UP: 19 s	DOWN: 15 s	
BOOM EXTENSION	OUT: 26 s	IN: 18 s	
ROTATION	90°	12s	

HYDRAULIC REQUIREMENTS

PRESSURE	2750 PSI
FLOW	6 GPM

ELECTRICAL REQUIREMENTS

VOLTAGE	12 VDC
FUSE	15 AMP

NOTE: FUNCTION TIMES ARE BASED ON THESE INPUT VALUES



F1118-E  
1/23/20

HOUSTON, TEXAS  
FAX: (800) 824-5559 (USA & Canada)  
FAX: (713) 688-6324  
PHONE: (713) 688-5533  
[www.liftmoore.com](http://www.liftmoore.com)

<b>PERIODIC MAINTENANCE SCHEDULE</b>		
MODEL 3660 CRANES		
<b>BOLTS</b>		
MOUNTING BOLTS	7/8-9 GRADE 8 TORQUE 600FT-LBS DRY	EVERY 4 MONTHS
BEARING BOLTS	5/8-11 GRADE 8 TORQUE 220FT-LBS DRY	EVERY 4 MONTHS
<b>LUBRICATION</b>		
GREASE FITTINGS	SEE DRAWING 50048	EVERY OTHER WEEK
HYDRAULIC FLUID	STANDARD Chevron AW Hydraulic Oil 46 or equivalent SAE 15 weight oil  COLD WEATHER AW 32 or equivalent SAE 10 weight oil	CHECK DAILY, FILL AS NEEDED
WINCH GEARBOX	Recommended: EP140 OIL ¾ 85W140 Gear Oil  Equivalent: Sunep 460 or equivalent ISO Grade 460 or AGMA Grade 7EP	EVERY MONTH
ROTATION GEARBOX	Sunco Prestige 740 EP or NLGI Grade 0	EVERY MONTH
BEARING (ZERK AND TEETH)	Oil Center Research PM 600 Military grease or equivalent Benton Based Grease NLGI Grade 2	EVERY 6 HOURS OF OPERATION



## CRANE LUBRICATION POINTS

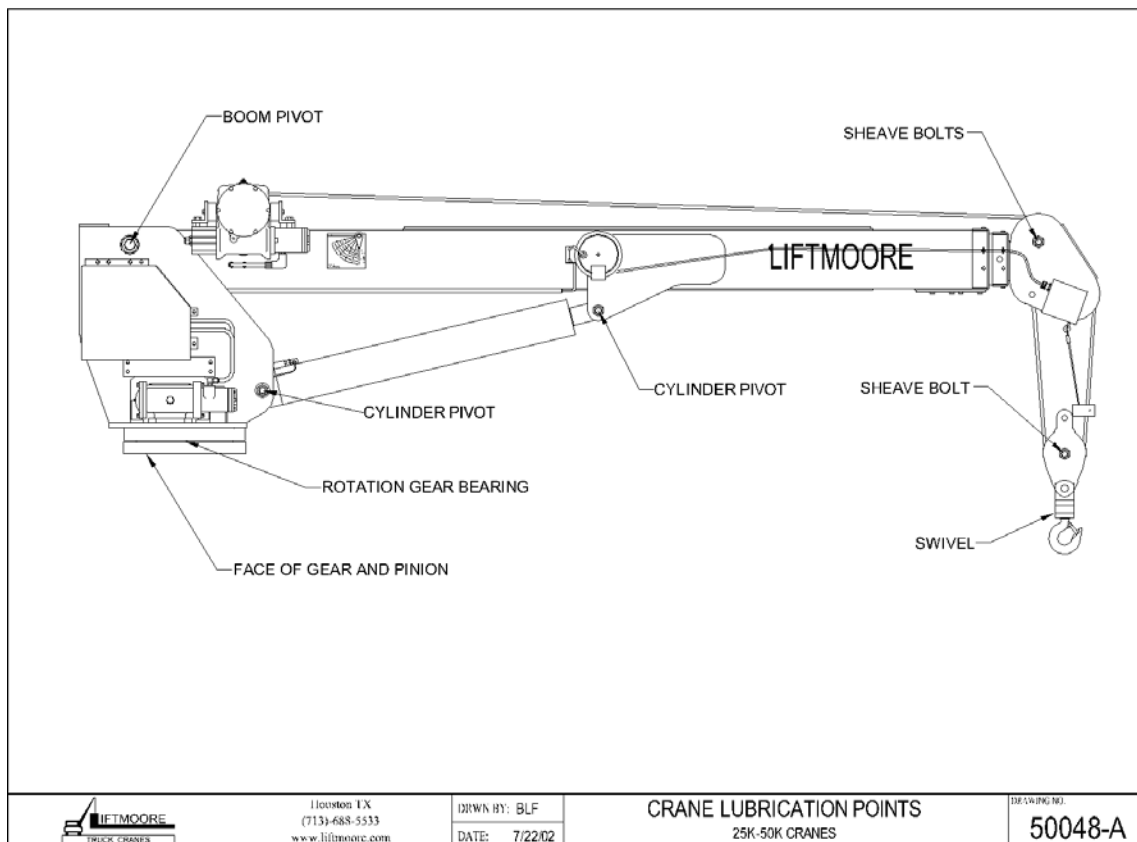

Houston TX  
(713) 688-5533  
www.liftmoore.com

DESIGN BY: BLF
DATE: 7/22/02

CRANE LUBRICATION POINTS  
25K-50K CRANES

50048-A



F1118-E  
1/23/20

HOUSTON, TEXAS  
FAX: (800) 824-5559 (USA & Canada)  
FAX: (713) 688-6324  
PHONE: (713) 688-5533  
www.liftmoore.com

THIS PAGE INTENTIONALLY LEFT BLANK



F1118-E  
1/23/20

HOUSTON, TEXAS  
FAX: (800) 824-5559 (USA & Canada)  
FAX: (713) 688-6324  
PHONE: (713) 688-5533  
[www.liftmoore.com](http://www.liftmoore.com)



**LIST FOR BOX, CRANE PARTS 3660XP**

Items with \* have detailed DWG's.

P/N 29221- BOX, CRANE PARTS 3660XP-20  
BAIL ATB LS, DTCH VALVE, HORN

- |     |                                                     |      |
|-----|-----------------------------------------------------|------|
| 1)  | P/N 29220 - MANUAL, CRANE 3660XP-20 HE.....         | 1pc  |
| 2)  | P/N 19487 - CW, 10 GA X 300".....                   | 1pc  |
| 3)  | P/N 18457 - FUSE HOLDER, ATO 12GA SEALED.....       | 1pc  |
| 4)  | P/N 21154 - FUSE, 30 AMP BLADE.....                 | 1pc  |
| 5)  | P/N 32613 - ADAPTER, 8MJ-10MJ.....                  | 1pc  |
| 6)  | P/N 17012 - SWITCH, TOGGLE SPST MAINT. /S.....      | 1pc  |
| 7)  | P/N 17011 - BRACKET, SWITCH MNT. HYD. CRN.....      | 1pc  |
| 8)  | P/N 16781 - TERMINAL, RING 10-12 GA #8.....         | 2pcs |
| 9)  | P/N 17013 - PLATE, ON-OFF FOR TOGGLE SWCH.....      | 1pc  |
| 10) | P/N 18600 - PLATE, CRANE-TRUCK STABILITY CHART..... | 1pc  |
| 11) | P/N 28992 - DECAL, LOAD CAPACITY 36,000.....        | 1pc  |
| 12) | P/N 23144 - LEVEL & TAPE ASSEMBLY.....              | 1pc  |
| 13) | P/N 30675 - COVER, TOGGLE SWITCH.....               | 1pc  |
| 14) | P/N 70053 - NUT, TOGGLE SWITCH.....                 | 1pc  |
| 15) | P/N 70054 - WASHER, LOCK TOGGLE SWITCH.....         | 1pc  |
| 16) | P/N 70055 - SCREW, MH FH 6-32 X 0.25.....           | 2pcs |
| 17) | *P/N 24081 - BLOCK, TRAV ASSY 6.0K lbs/6.5D. ....   | 1pc  |



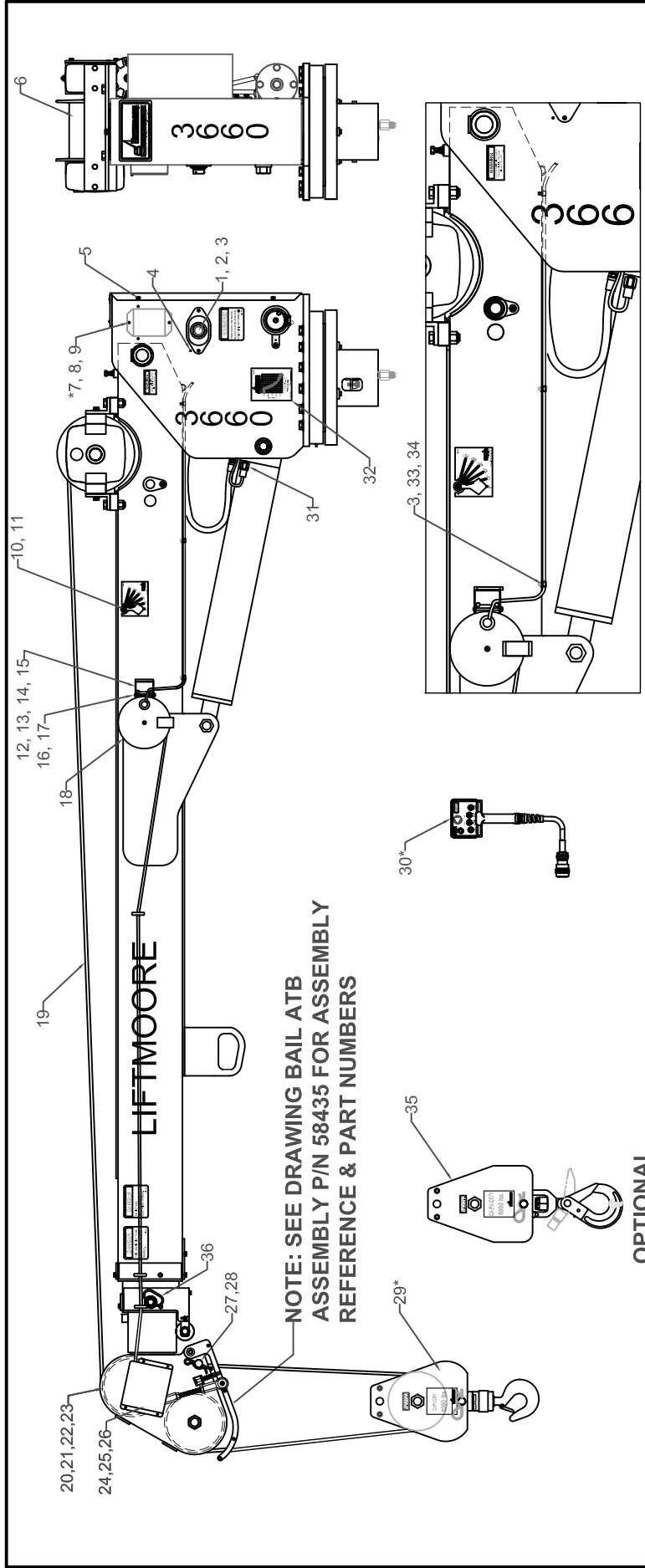

NOTE: SEE DRAWING BAIL ATB ASSEMBLY P/N 58435 FOR ASSEMBLY REFERENCE & PART NUMBERS

OPTIONAL

NOTE: CORD REEL ASSEMBLY DETAIL

ITEMS WITH \* HAVE DETAIL DRAWINGS

#	PN	DESCRIPTION	QTY	#	PN	DESCRIPTION	QTY	#	PN	DESCRIPTION	QTY
1	25125	EWH, DTCH HYD 3RD G XP ATB-BD	1	16	33410	SCREW, MH RD 10-24 X 3.00	1	31	20415	SWITCH, PRES ASSY 2050PSIDTCH	1
2	30457	SCREW, HHC 0.25-20 X 0.75 GR5	2	17	33409	NUT, HEX NYLOC 10-24 GR2	1	32	24186	PLATE, SERIAL 6036/3660	1
3	30889	WASHER, LOCK 0.25 GR5 PLATED	5	18	20407	REEL, CORD 20 FT ASSY DTCH	1	33	26582	SCREW, SOC HD 0.25-20 X 0.37 SS	3
4	33144	SCREW, MH HX 10-24 X 0.50	1	19	32384	ROPE, WIRE 0.37 X 95' W/THIMBLE	1	34	24960	CLAMP, HOSE SUPPORT 0.25	3
5	32589	SCREW, HWHSMS 0.25-20 X 0.75	4	20	20541	SHEAVE ASSY 6.58PD X 0.37 ROPE	2	35	22592	BLOCK, TRAV ASSY 6.0K lbs/6.5D	1
6	30528	SCREW, SET 0.37-16 X 0.75	1	21	34468	SCREW, SHEAVE SINGLE 1-8 3.25	2	36	33203	PIN, HITCH 0.75 X 6.00 W/H-PIN	1
7	22569	BOARD, RELAY 3RD G XP	1	22	30838	NUT, HEX NYLOC 1.00-8 GRADE 5	2	NOT SHOWN:			
8	17164	SCREW, SOC HD 10-24 X 0.62 SS	2	23	31258	WASHER, FLAT 1.00 SAE GRADE 8	2	19847	CONNECTOR, DTCH 2P PLUG	1	
9	32639	WASHER, LOCK #10 GR2 PLATED	2	24	27192	COVER, BAIL ATB	1	19845	CONNECTOR, DTCH 2P RECPT	1	
10	22394	PENDULUM, LOAD RADIUS DIA. HD	2	25	26909	SCREW, SOC HD 10-24 X 0.37 SS	4	19846	WEDGE, DEUTSCH 2P PLUG	1	
11	31017	SCREW, SHOULDER 0.31-18 X 0.75	2	26	26910	WASHER, FLAT #10 SS	4	19848	WEDGE, DEUTSCH 2P RECPT	1	
12	70012	BRACKET, CORD REEL	1	27	32658	PIN, CLEVIS 0.87 X 3.50 PLATED	1	20135	DECAL KIT 3660X-20	1	
13	30833	NUT, HEX NYLOC 0.25-20 GR2	2	28	31948	CLIP, HAIRPIN 0.87 - 1.00	1				
14	31110	WASHER, FLAT 0.25 GR5 PLATED	2	29	24081	BLOCK, TRAV ASSY 6.0K lbs/6.5D N.H.	1				
15	30457	SCREW, HHC 0.25-20 X 0.75 GR5	2	30	24694	CONTROL, PENDANT XP	1				

Houston TX  
(713)-688-5533  
www.liftmoore.com

DRWN BY: JE  
DATE: 1/9/20

CRANE ASSY 3660XP-20 RL E-STOP  
RND BAIL ATB, WHORN

DRAWING NO. 29218-0

**Parts List**

Item	Qty	Part Number	Description
1	1	32004BB	PENDANT WITH HALL TRIGGER AND BACK COVER
2	1	32004KA	CABLE ASSEMBLY WITH CONNECTOR AND INTERNAL JUMPERS
3	1	70040	CORD GRIP, ST THRU PLST, 3/4" NPT
4	1	070-070-1832	DECAL, PENDANT, GUIDER, 4SW, LIFTMOORE
5	4	30454	SW, TOGGLE, SPDT, (ON)-OFF-(ON), QUICK CONNECT
6	4	30675	SW, SEALING BOOT, BLACK, TOGGLE-15/32-32NS
7	1	240-109-8002	SW, PUSH BUTTON, N.O., GREEN DOME, SCREW CONNECT
8	1	24073	SW, E-STOP, TWIST TO RELEASE, NC CONTACT

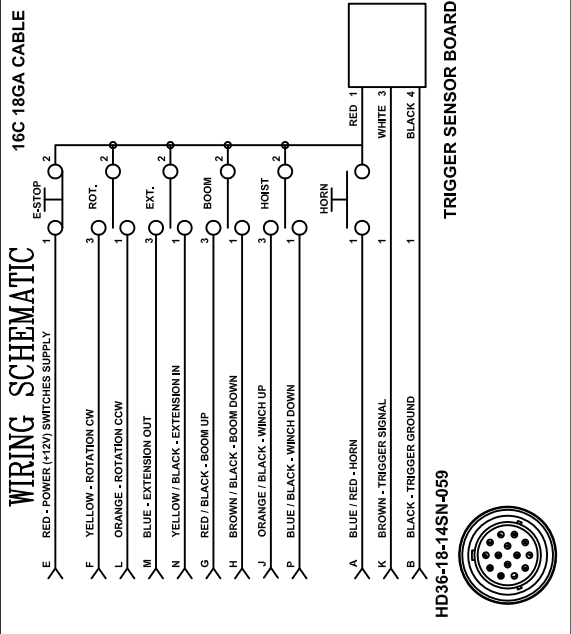
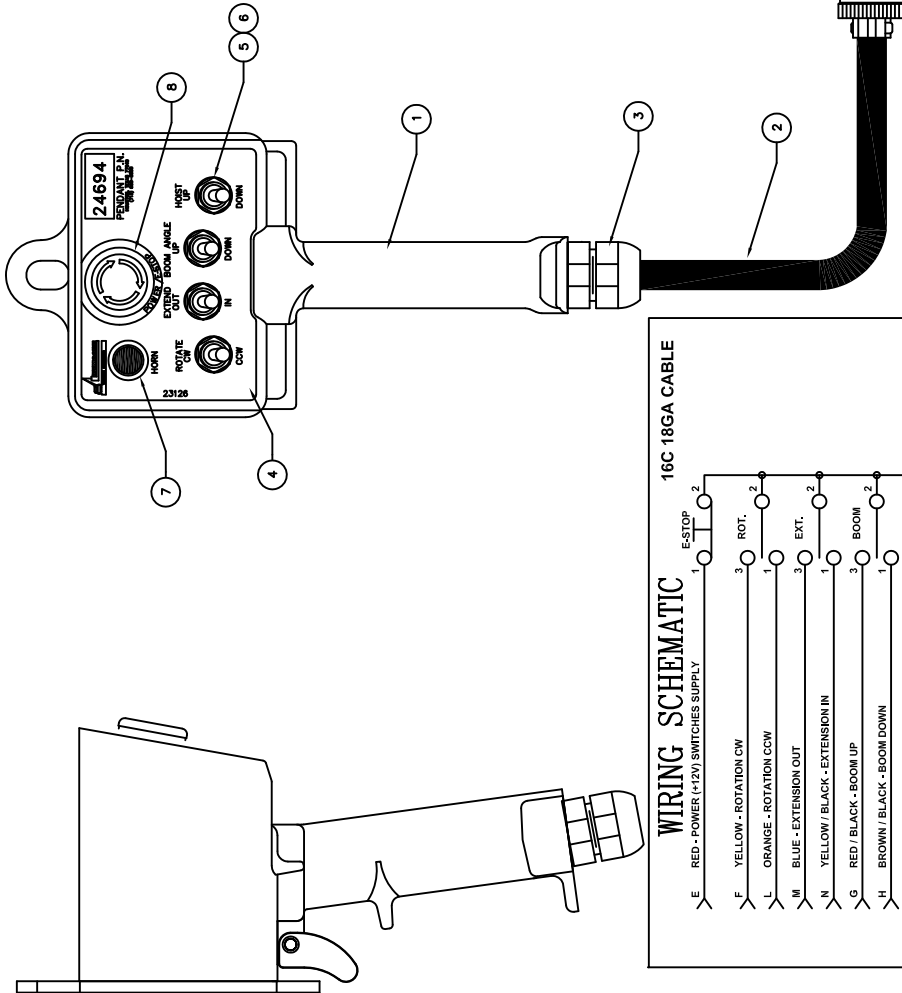

PIN	COLOR	DESCRIPTION
A	BLUE/RED	HORN
B	BLACK	TRIGGER GROUND
C	NC	NC
D	NC	NC
E	RED	SWITCHES SUPPLY +12V
F	YELLOW	ROTATION CW
G	RED/BLACK	BOOM UP
H	BROWN/BLACK	BOOM DOWN
J	ORANGE/BLACK	WINCH UP
K	BROWN	TRIGGER SIGNAL
L	ORANGE	ROTATION CCW
M	BLUE	EXTENSION OUT
N	YELLOW/BLACK	EXTENSION IN
P	BLUE/BLACK	WINCH DOWN



Houston TX  
(713)-688-5533  
www.liftmoore.com

DRWN BY: JE  
DATE: 10/25/11

**CONTROL, PENDANT XP HALL TRIG**  
HALL EFF. TRIGGER W/ E-STOP, HORN

DRAWING NO.  
**24694-H**

3RD GENERATION RELAY BOARD	
Pin No.	Description
1	Ground
2	Trigger Signal Input
3	Proportional Valve Output
4	Pressure Switch Input
5	ATB Switch Input
6	Winch Up Switch Input
7	Elevation Down Switch Input
8	Extension Out Switch Input
9	Extension Out Output
10	Elevation Down Output
11	Winch Up Output
12	Supply (9 To 30 VDC)

### ERROR CODE CHART

ERROR CODE COUNT	PROBABLE CAUSE
1	No Input To ATB Switch Input
2	No Input To Pressure Switch Input Or Overload Condition
3	Short Or Overload To Winch Up Output
4	Short Or Overload To Elevation Down Output
5	Short Or Overload To Extension Out Output
6	Trigger Input Out Of Range

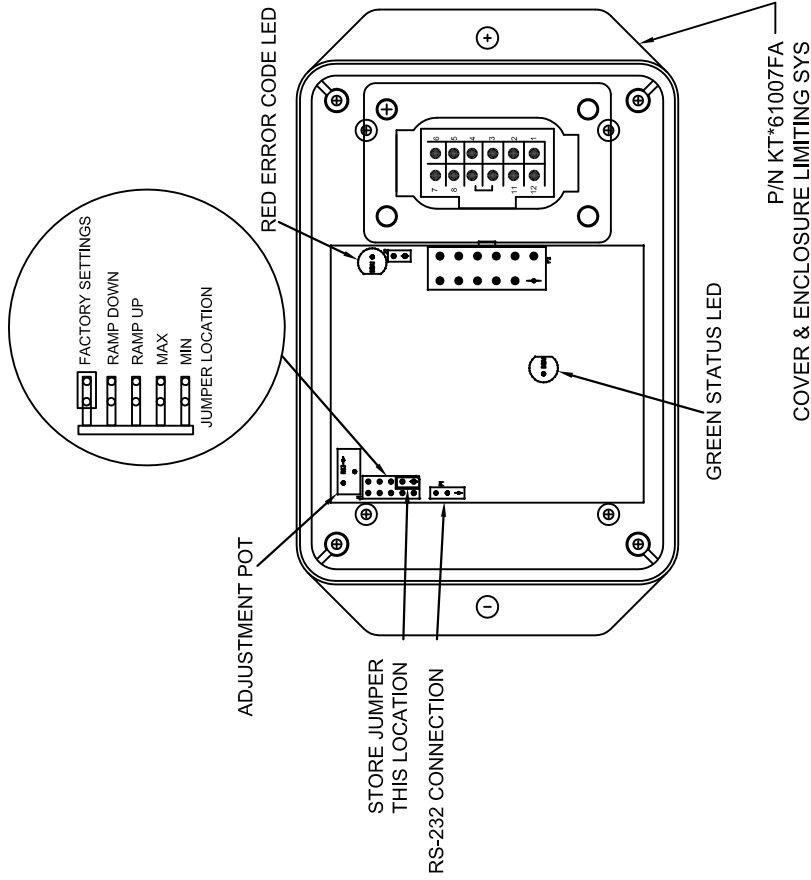

To Display an error code, the controller turns on and off the error code LED a certain number of times with a pause at the end. It repeats the code until the problem is resolved. The **Error Code Chart** is provided to assist the service personnel in troubleshooting the system.

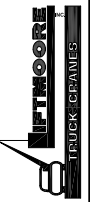

Houston TX  
(713)-688-5533  
www.liftmoore.com

DRWN BY: JC

DATE: 06/11/07

BOARD, RELAY 3RD G XP ATB-BD

ATB DOES NOT STOP BOOM DOWN

DRAWING NO.

22569-C

# ASSEMBLY

REPORT ANY ERRORS OR CHANGES TO ENGINEERING IMMEDIATELY

## NOTE

CROWN PLATE FOR REFERENCE ONLY

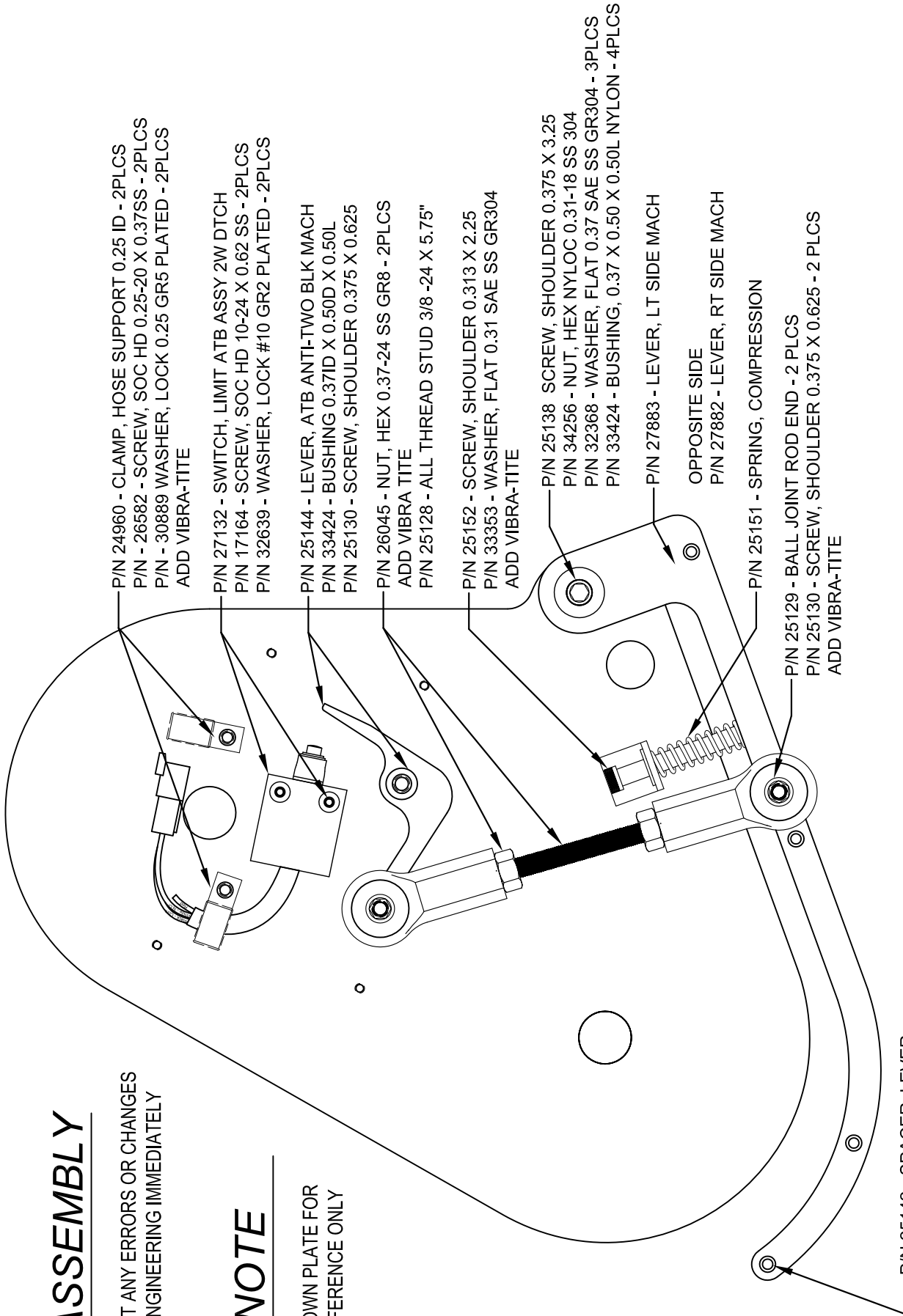

P/N 24960 - CLAMP, HOSE SUPPORT 0.25 ID - 2PLCS  
 P/N - 26582 - SCREW, SOC HD 0.25-20 X 0.37SS - 2PLCS  
 P/N - 30889 WASHER, LOCK 0.25 GR5 PLATED - 2PLCS  
 ADD VIBRA-TITE

P/N 27132 - SWITCH, LIMIT ATB ASSY 2W DTCH  
 P/N 17164 - SCREW, SOC HD 10-24 X 0.62 SS - 2PLCS  
 P/N 32639 - WASHER, LOCK #10 GR2 PLATED - 2PLCS

P/N 25144 - LEVER, ATB ANTI-TWO BLK MACH  
 P/N 33424 - BUSHING 0.37ID X 0.50D X 0.50L  
 P/N 25130 - SCREW, SHOULDER 0.375 X 0.625

P/N 26045 - NUT, HEX 0.37-24 SS GR8 - 2PLCS  
 ADD VIBRA TITE  
 P/N 25128 - ALL THREAD STUD 3/8 -24 X 5.75"

P/N 25152 - SCREW, SHOULDER 0.313 X 2.25  
 P/N 33353 - WASHER, FLAT 0.31 SAE SS GR304  
 ADD VIBRA-TITE

P/N 25138 SCREW, SHOULDER 0.375 X 3.25  
 P/N 34256 - NUT, HEX NYLOC 0.31-18 SS 304  
 P/N 32368 - WASHER, FLAT 0.37 SAE SS GR304 - 3PLCS  
 P/N 33424 - BUSHING, 0.37 X 0.50 X 0.50L NYLON - 4PLCS

P/N 27883 - LEVER, LT SIDE MACH  
 OPPOSITE SIDE  
 P/N 27882 - LEVER, RT SIDE MACH

P/N 25151 - SPRING, COMPRESSION  
 P/N 25129 - BALL JOINT ROD END - 2 PLCS  
 P/N 25130 - SCREW, SHOULDER 0.375 X 0.625 - 2 PLCS  
 ADD VIBRA-TITE

P/N 25142 - SPACER, LEVER  
 P/N 27885 - LEVER, BAIL SUPPORT - MACH - 2PLCS  
 P/N 17164 - SCREW, SOC HD 10-24 X 0.62 SS - 8PLCS  
 ADD VIBRA-TITE

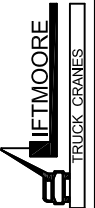

Houston TX  
 (713)-688-5533  
 www.liftmoore.com

DRWN BY: AA  
 DATE: 02/25/16

DWG, BAIL ATB ASSEMBLY  
 6036/3660/4064/5080 BAIL ATB

DRAWING NO.

58435-D

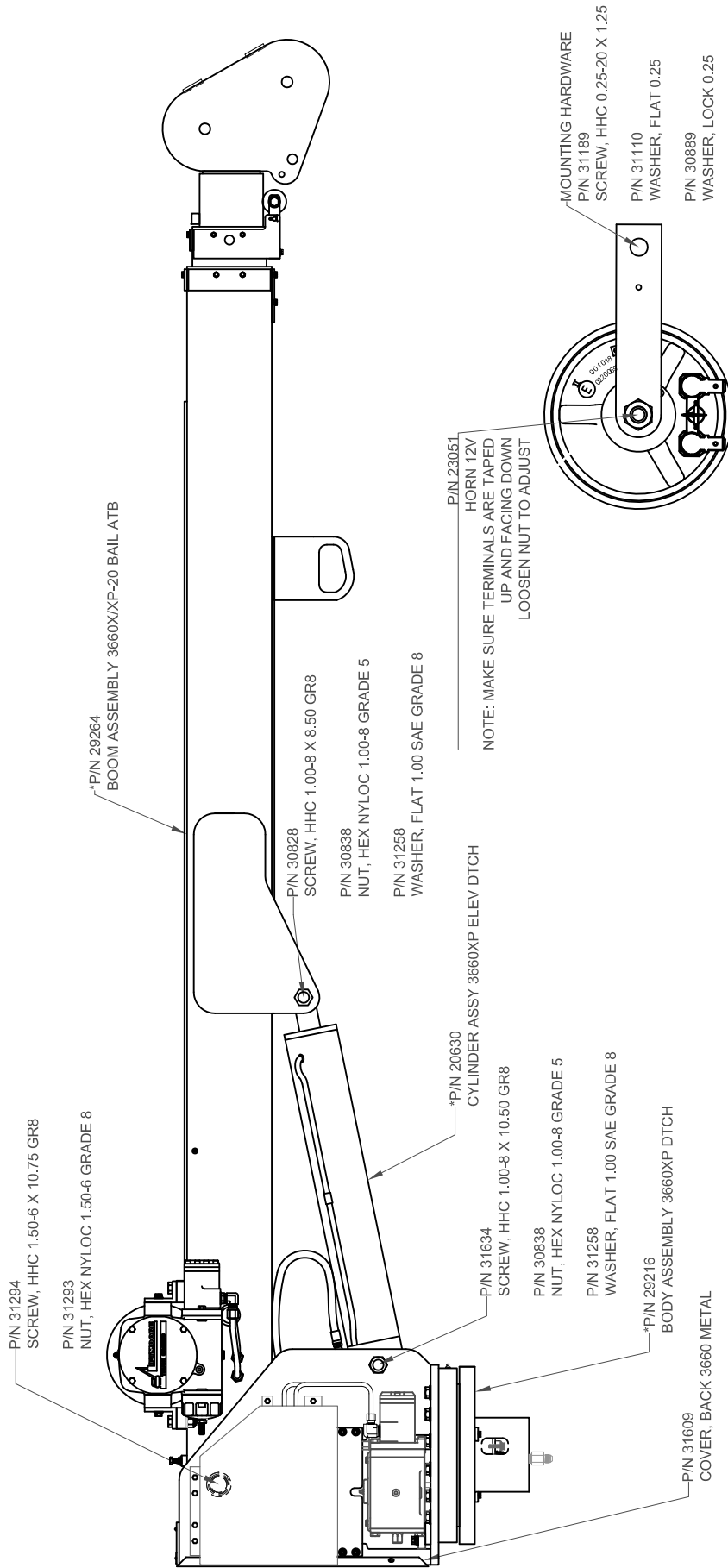

ITEMS WITH \* HAVE DETAIL DRAWINGS

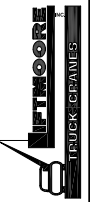

Houston TX  
 (713)-688-5533  
 www.liftmoore.com

DRWN BY: JE  
 DATE: 1/8/20

**BOOM-BODY ASSY 3660X-20 RL**  
 PERFECTION GEAR SP. REDUCER

DRAWING NO.

**29217-0**

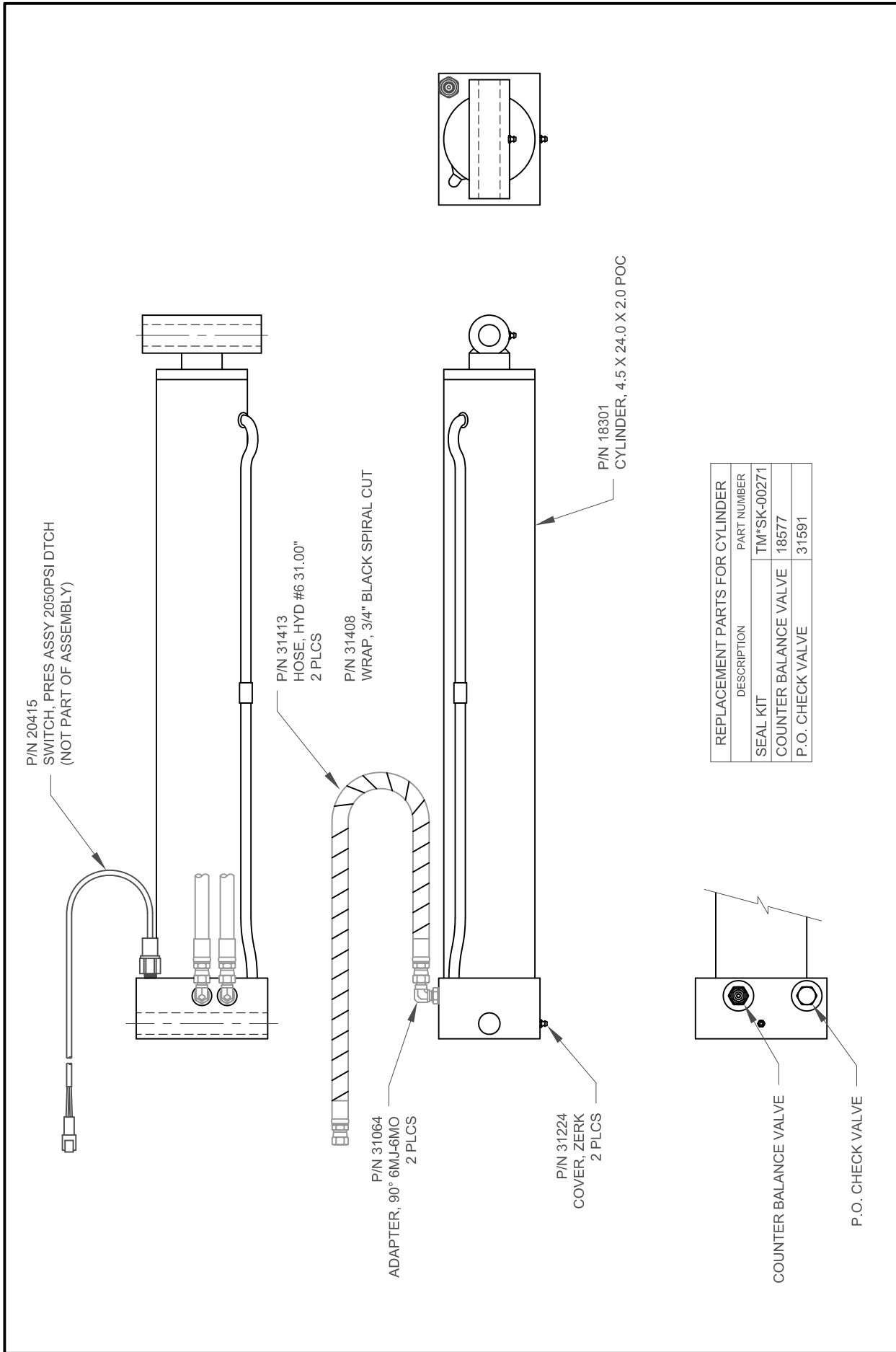

DRAWING NO.  
**20630-A**

**CYLINDER ASSY 3660XP ELEV DTCH**

DRWN BY: JC  
DATE: 7/25/08

Houston TX  
(713)-688-5533  
www.liftmoore.com

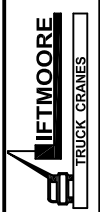

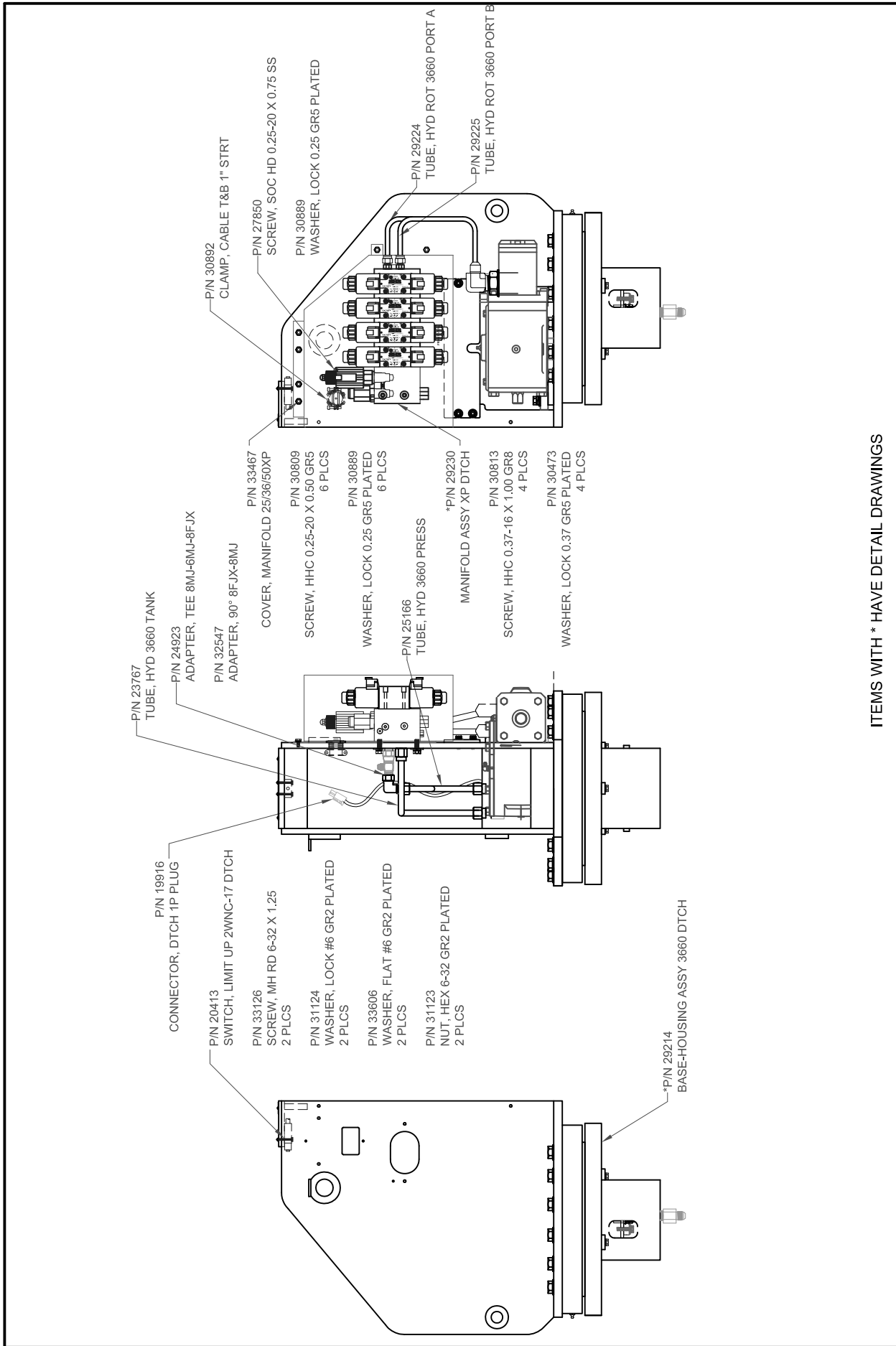

ITEMS WITH \* HAVE DETAIL DRAWINGS

DRAWING NO.  
**29216-0**

**BODY ASSEMBLY 3660XP DTCH**

DRWN BY: JE

DATE: 1/8/20

Houston TX  
(713)-688-5533  
www.liftmoore.com







BY: JE  
DATE: 1/22/20

# MANIFOLD ASSY XP DTCH

3660

4-9

DOCUMENT NO.

29230-0

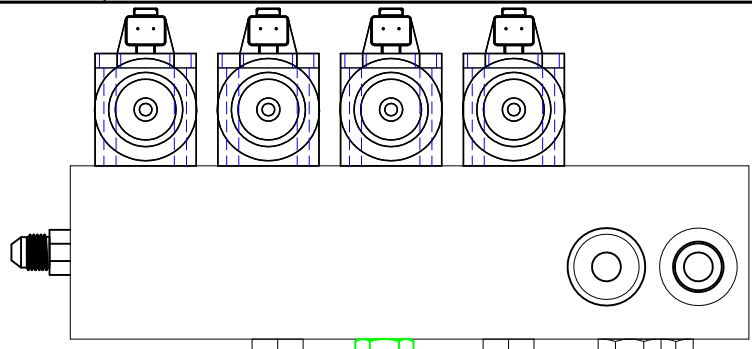

TOP VIEW

P/N 30899  
ADAPTER, 6FP-8MO  
TIGHTEN TO 25 FT. LBS  
4 PLCS

P/N 30978  
ADAPTER, 90° L 6MJ-6MPL  
2 PLCS  
LEAVE LOOSE

P/N 30898  
ADAPTER, 6MJ-8MO  
2 PLCS  
TIGHTEN TO 25 FT. LBS

P/N 22187  
ADAPTER, 90° LL 6MP-8MJ

P/N 31908  
ADAPTER, 8MJ-8MO X 1.48  
2 PLCS  
TIGHTEN TO 25 FT. LBS

P/N 31063  
ADAPTER, 6MJ-6MO  
2 PLCS  
TIGHTEN TO 25 FT. LBS.

P/N 20864  
ADAPTER, 6MJ-8FJ  
2 PLCS  
LEAVE LOOSE

P/N 24993  
MANIFOLD PRE-ASSY XP DTCH

BACK VIEW

P/N 31953  
ADAPTER, 90° LLL 6MPL-8MJ  
LEAVE LOOSE  
2 PLCS

INSTALL  
P/N 24432  
VALVE ASSY 4W/3P/12V/OC DTCH  
OPEN CENTER VALVES

P/N 30956  
SCREW, SOC HD 10-24X2.00  
GRADE 5

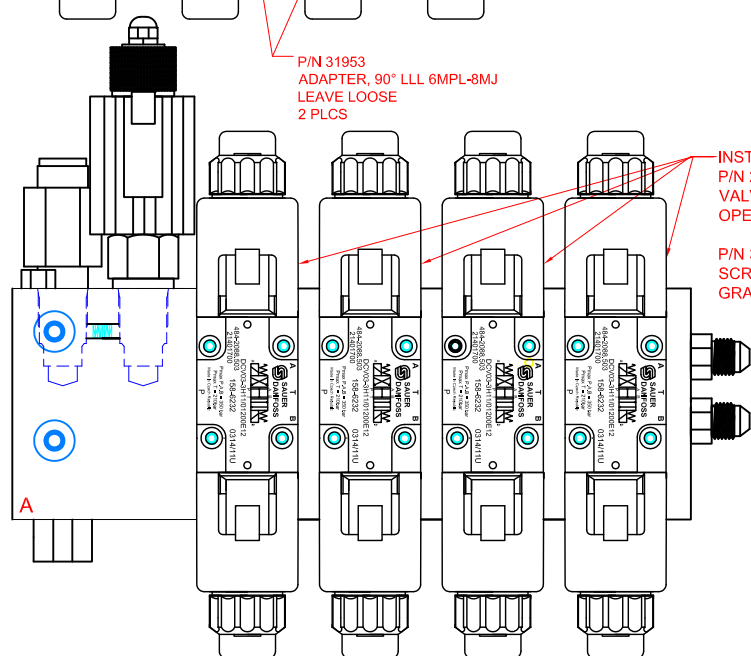

FRONT VIEW

**PRE-BUILD**

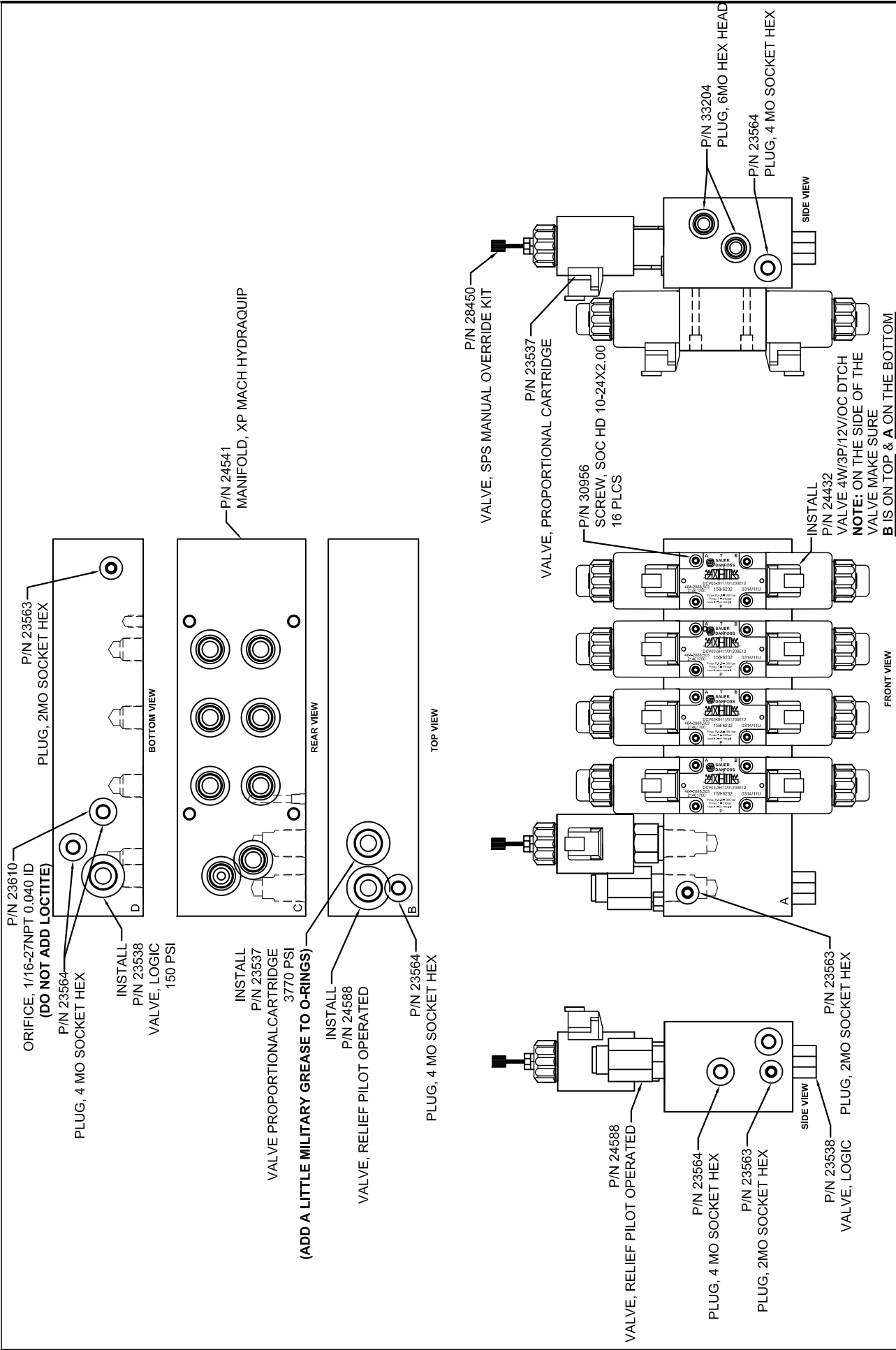

DRAWING NO.  
**24993-B**

**MANIFOLD PRE-ASSY XP DTCH**

DRWN BY: JE  
DATE: 6/4/12

Houston TX  
(713)-688-5533  
www.liftmoore.com

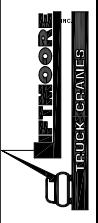

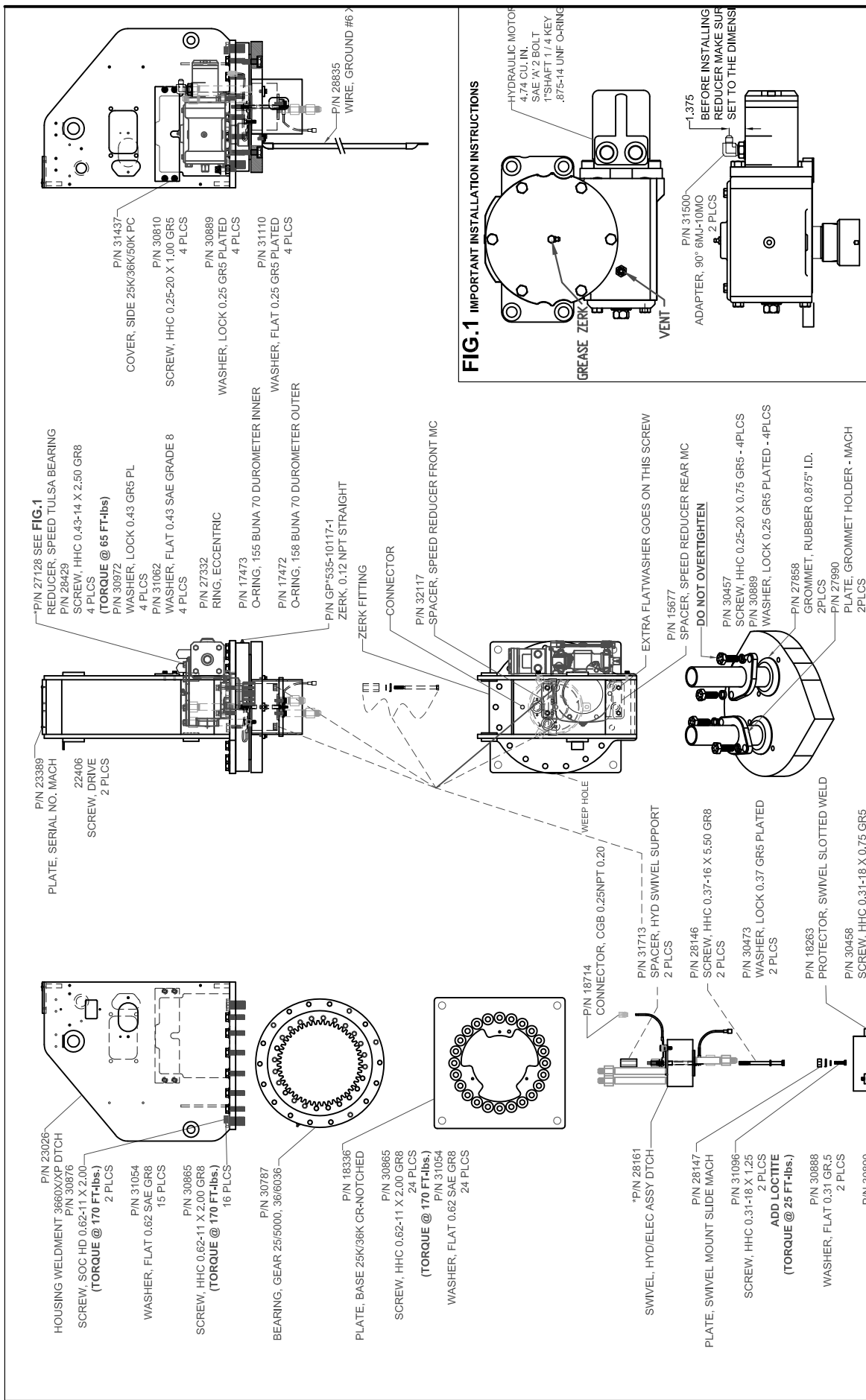

- PIN 27128 SEE FIG.1
- REDUCER, SPEED TULSA BEARING
- PIN 28429
- SCREW, HHC 0.43-14 X 2.50 GR8 4 PLCS
- (TORQUE @ 65 FT-lbs)
- PIN 30972
- WASHER, LOCK 0.43 GR5 PL 4 PLCS
- PIN 31062
- WASHER, FLAT 0.43 SAE GRADE 8 4 PLCS
- PIN 27332
- RING, ECCENTRIC
- PIN 17473
- O-RING, 158 BUNA 70 DUROMETER INNER
- PIN 17472
- O-RING, 158 BUNA 70 DUROMETER OUTER
- PIN GP\*535-10117-1
- ZERK, 0.12 NPT STRAIGHT
- ZERK FITTING
- CONNECTOR
- PIN 32117
- SPACER, SPEED REDUCER FRONT MC
- PIN 15677
- SPACER, SPEED REDUCER REAR MC
- DO NOT OVERTIGHTEN
- PIN 30457
- SCREW, HHC 0.25-20 X 0.75 GR5 -4PLCS
- PIN 30889
- WASHER, LOCK 0.25 GR5 PLATED -4PLCS
- PIN 27858
- GROMMET, RUBBER 0.875" I.D. 2PLCS
- PIN 27990
- PLATE, GROMMET HOLDER - MACH 2PLCS

- PIN 23389
- PLATE, SERIAL NO. MACH 22406
- SCREW, DRIVE 2 PLCS
- PIN 23026
- HOUSING WELDMENT 3660XXP DTCH
- PIN 30876
- SCREW, SOC HD 0.62-11 X 2.00 (TORQUE @ 170 FT-lbs.) 2 PLCS
- PIN 31054
- WASHER, FLAT 0.62 SAE GR8 15 PLCS
- PIN 30865
- SCREW, HHC 0.62-11 X 2.00 GR8 (TORQUE @ 170 FT-lbs.) 16 PLCS
- PIN 30787
- BEARING, GEAR 25/5000, 36/6036
- PIN 18336
- PLATE, BASE 25K/36K CR-NOTCHED
- PIN 30865
- SCREW, HHC 0.62-11 X 2.00 GR8 24 PLCS
- (TORQUE @ 170 FT-lbs.)
- PIN 31054
- WASHER, FLAT 0.62 SAE GR8 24 PLCS
- PIN 18714
- CONNECTOR, CGB 0.25NPT 0.20
- PIN 31713
- SPACER, HYD SWIVEL SUPPORT 2 PLCS
- PIN 28146
- SCREW, HHC 0.37-16 X 5.50 GR8 2 PLCS
- PIN 30473
- WASHER, LOCK 0.37 GR5 PLATED 2 PLCS
- PIN 18263
- PROTECTOR, SWIVEL SLOTTED WELD
- PIN 30458
- SCREW, HHC 0.31-18 X 0.75 GR5 3 PLCS
- PIN 30890
- WASHER, LOCK 0.31 GR5 PLATED 3 PLCS

- PIN 27128 SEE FIG.1
- REDUCER, SPEED TULSA BEARING
- PIN 28429
- SCREW, HHC 0.43-14 X 2.50 GR8 4 PLCS
- (TORQUE @ 65 FT-lbs)
- PIN 30972
- WASHER, LOCK 0.43 GR5 PL 4 PLCS
- PIN 31062
- WASHER, FLAT 0.43 SAE GRADE 8 4 PLCS
- PIN 27332
- RING, ECCENTRIC
- PIN 17473
- O-RING, 158 BUNA 70 DUROMETER INNER
- PIN 17472
- O-RING, 158 BUNA 70 DUROMETER OUTER
- PIN GP\*535-10117-1
- ZERK, 0.12 NPT STRAIGHT
- ZERK FITTING
- CONNECTOR
- PIN 32117
- SPACER, SPEED REDUCER FRONT MC
- PIN 15677
- SPACER, SPEED REDUCER REAR MC
- DO NOT OVERTIGHTEN
- PIN 30457
- SCREW, HHC 0.25-20 X 0.75 GR5 -4PLCS
- PIN 30889
- WASHER, LOCK 0.25 GR5 PLATED -4PLCS
- PIN 27858
- GROMMET, RUBBER 0.875" I.D. 2PLCS
- PIN 27990
- PLATE, GROMMET HOLDER - MACH 2PLCS

ITEMS WITH \* HAVE DETAIL DRAWINGS

Houston TX  
(713)-688-5533  
www.liftmoore.com

DRWN BY: JE  
DATE: 1/23/20

BASE-HOUSING ASSY 3660 DTCH  
PERFECTION GEAR SPEED REDUCER

DRAWING NO. 29214-0



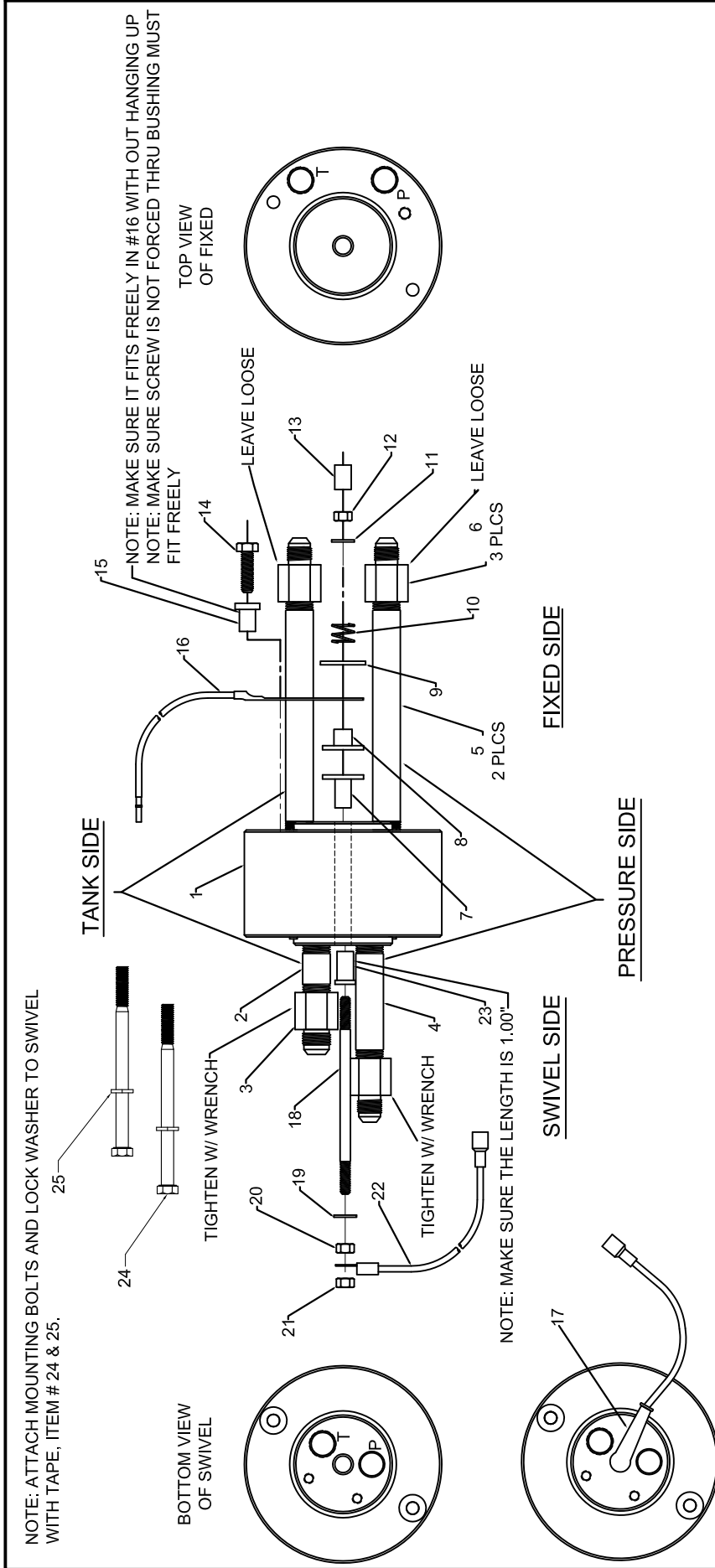

**NOTE**  
ON THE BOTTOM OF THE SWIVEL, THE TANK PORT USES A #10 FITTING, AND THE PRESSURE PORT USES A #8 FITTING.

#	PN	DESCRIPTION	QTY	#	PN	DESCRIPTION	QTY	#	PN	DESCRIPTION	QTY
1	28144	SWIVEL, HYDRAULIC 1/2" PORTS	1	9	32562	WASHER, FLAT 0.50 SS GRADE 304	1	17	30674	BOOT, RUBBER 1 & 1/0	1
2	31996	ADAPTER, NIPPLE 2.50" LG #8	1	10	31452	SPRING, SWIVEL	1	18	32277	STUD, 5/16-18 X 6 DOUBLE END	1
3	32468	ADAPTER, 8FP-10MJ	1	11	32368	WASHER, FLAT 0.37 SAE SS GR304	1	19	33353	WASHER, FLAT 0.31 SAE SS304	1
4	32321	ADAPTER, NIPPLE 4.00" LG #8	1	12	34256	NUT, HEX NYLOC 0.31-18 SS 304	1	20	34255	NUT, HEX 0.31-18 SS 304	1
5	32131	ADAPTER, NIPPLE 8.00" LG #8	2	13	32279	SLEEVE, SWIVEL SCREW INSULATOR	1	21	34256	NUT, HEX NYLOC 0.31-18 SS 304	1
6	31995	ADAPTER, 8FP-8MJ	3	14	23063	SCREW, HHC 0.37-16 X 1.25 GR8	1	22	32278	WIRE, SWIVEL SUPPLY W/TERMINAL	1
7	31382	SPACER, SWIVEL STUD INSULATOR	1	15	31451	INSULATOR, BOLT ELECTRIC	1	23	31383	SPACER, SWIVEL STUD INSULATOR	1
8	31381	SPACER, SWIVEL UPPER - BRONZE	1	16	20500	WIRE, SWIVEL HOT PLATE ASSY D	1	24	28146	SCREW, HHC 0.37-16 X 5.50 GR8	2
								25	30473	WASHER, LOCK 0.37 GR5 PLATED	2

Houston TX  
(713)-688-5533  
www.liftmoore.com

**SWIVEL, HYD/ELEC ASSY DTCH CTB**  
1/2" PORTS, COUNTER BORE HOLE

DRAWING NO.  
**28161-0**

DRWN BY: JE

DATE: 8/16/16

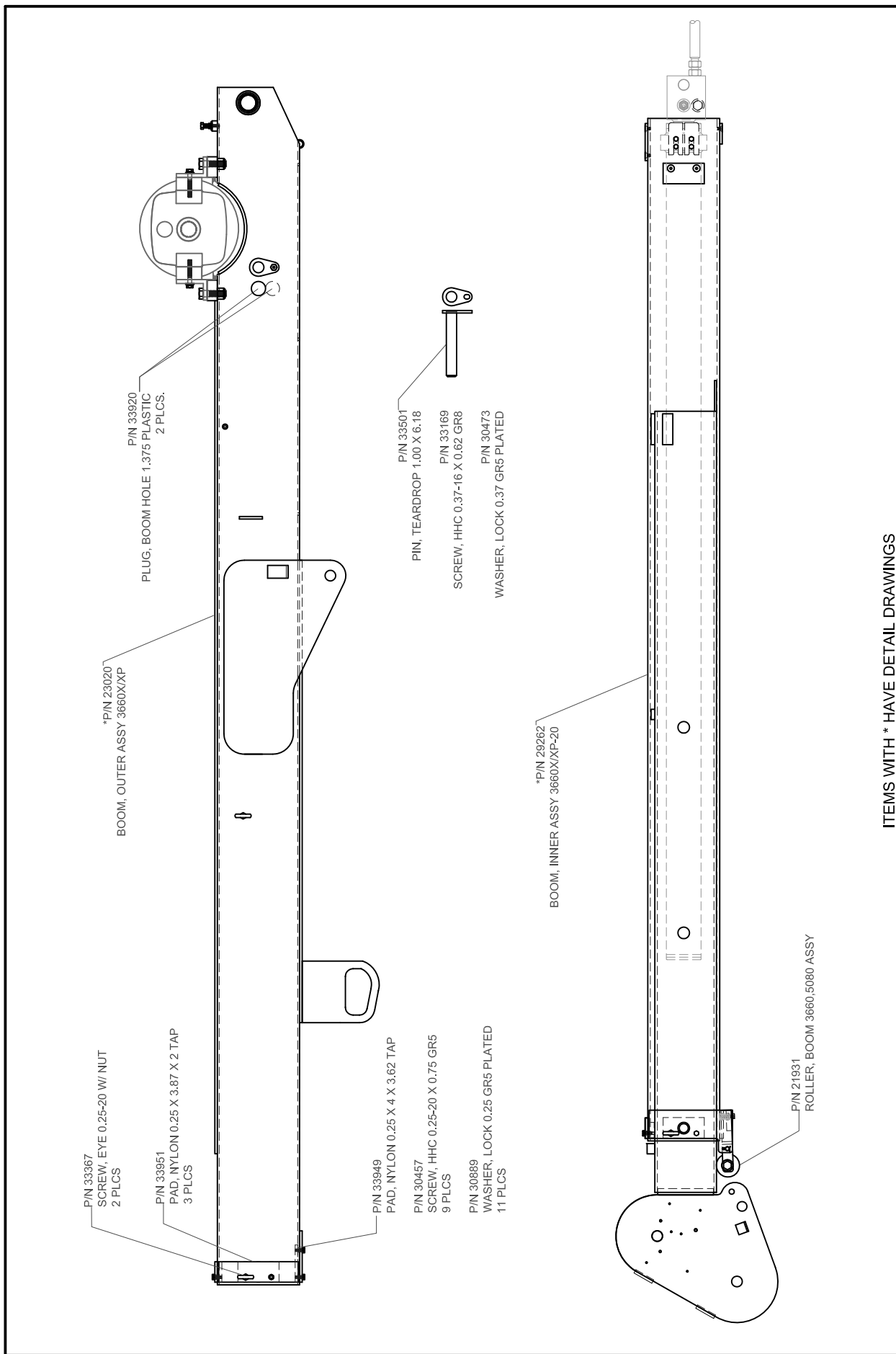

- P/N 33367  
SCREW, EYE 0.25-20 W/ NUT  
2 PLCS
- P/N 33951  
PAD, NYLON 0.25 X 3.87 X 2 TAP  
3 PLCS
- P/N 33949  
PAD, NYLON 0.25 X 4 X 3.62 TAP
- P/N 30457  
SCREW, HHC 0.25-20 X 0.75 GR5  
9 PLCS
- P/N 30889  
WASHER, LOCK 0.25 GR5 PLATED  
11 PLCS

\*P/N 23020  
BOOM, OUTER ASSY 3660/XP

P/N 33920  
PLUG, BOOM HOLE 1.375 PLASTIC  
2 PLCS.

- P/N 33501  
PIN, TEARDROP 1.00 X 6.18
- P/N 33169  
SCREW, HHC 0.37-16 X 0.62 GR8
- P/N 30473  
WASHER, LOCK 0.37 GR5 PLATED

\*P/N 29262  
BOOM, INNER ASSY 3660/XP-20

P/N 21931  
ROLLER, BOOM 3660,5080 ASSY

ITEMS WITH \* HAVE DETAIL DRAWINGS

**LIFTMOORE**  
TRUCK CRANES

Houston TX  
(713)-688-5533  
www.liftmoore.com

DRWN BY: JE  
DATE: 1/23/20

**BOOM ASSEMBLY 3660/XP-20 RL**

DRAWING NO.  
**29264-0**

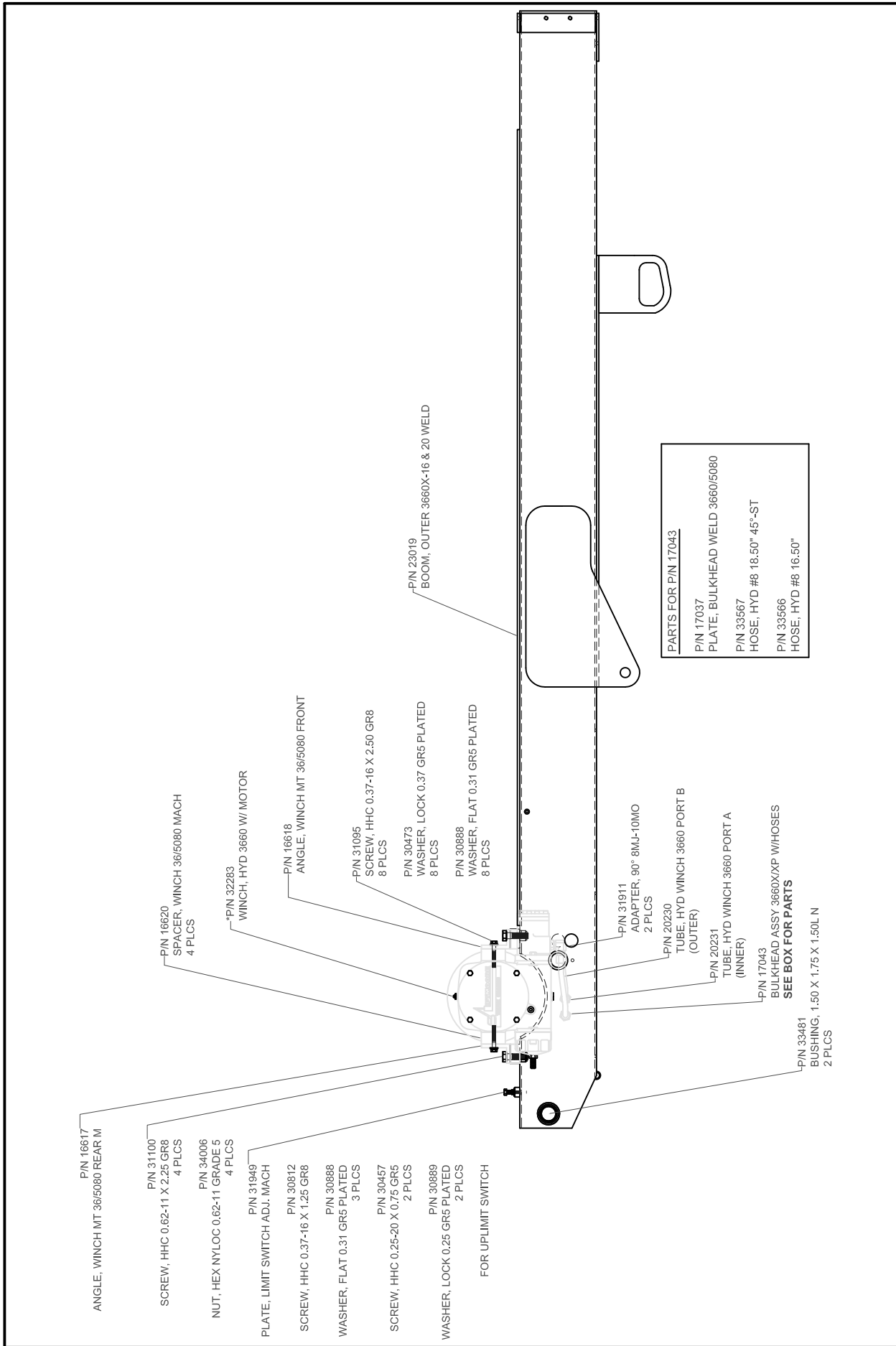

Houston TX  
 (713)-688-5533  
 www.liftmoore.com

DRWN BY: JC  
 DATE: 03/03/09

**BOOM, OUTER ASSY 3660X/XP**  
 16 & 20 FT; ATB ON LEFT SIDE

DRAWING NO.  
**23020-B**

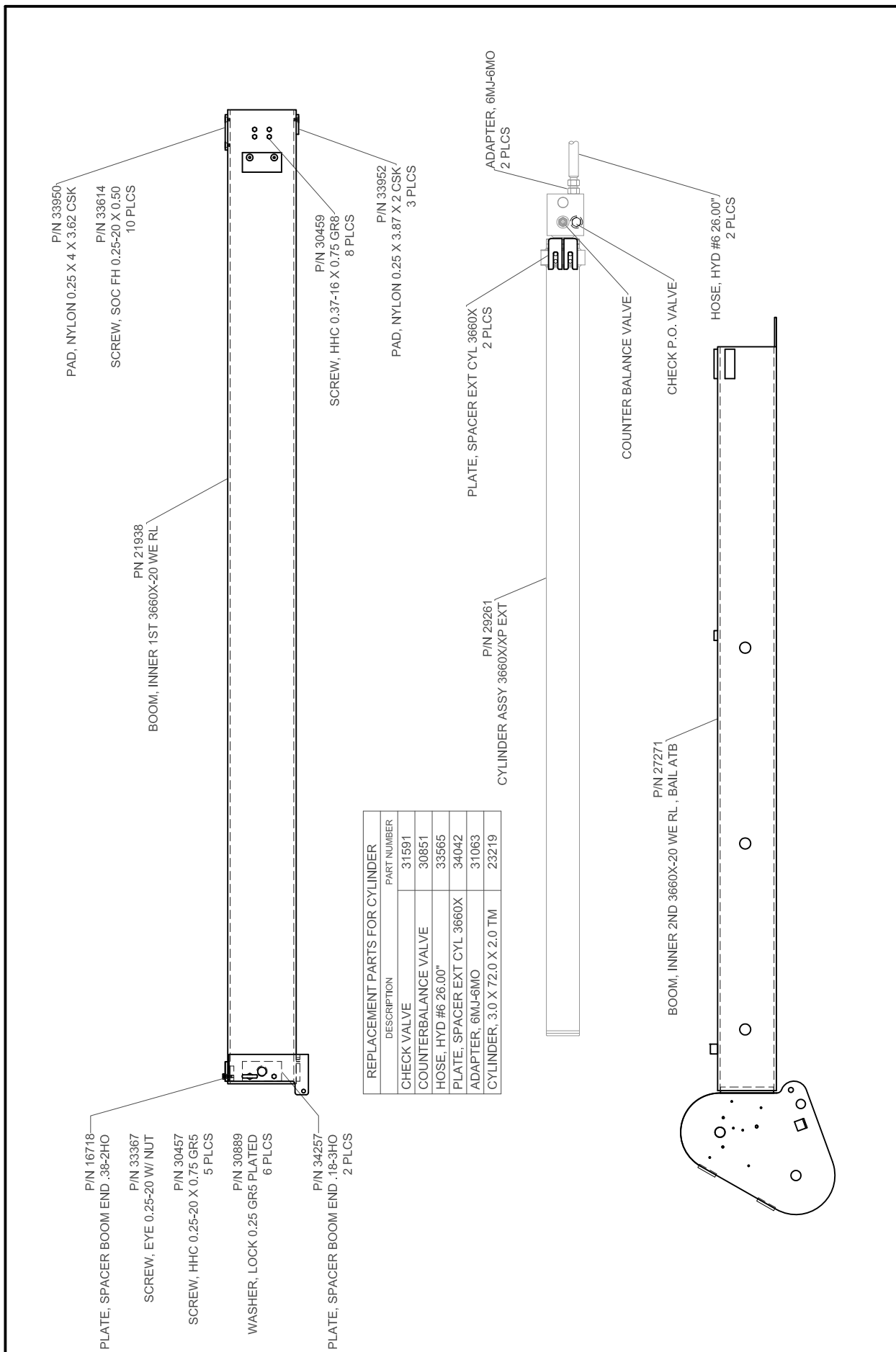

REPLACEMENT PARTS FOR CYLINDER	
DESCRIPTION	PART NUMBER
CHECK VALVE	31591
COUNTERBALANCE VALVE	30851
HOSE, HYD #6 26.00"	33565
PLATE, SPACER EXT CYL 3660X	34042
ADAPTER, 6MJ-6MO	31063
CYLINDER, 3.0 X 72.0 X 2.0 TM	23219

Houston TX  
(713)-688-5533  
www.liftmoore.com

DRWN BY: JE  
DATE: 1/23/20

**BOOM, INNER ASSY 3660X/XP-20**  
TMS CYLINDER

DRAWING NO.  
**29262-0**



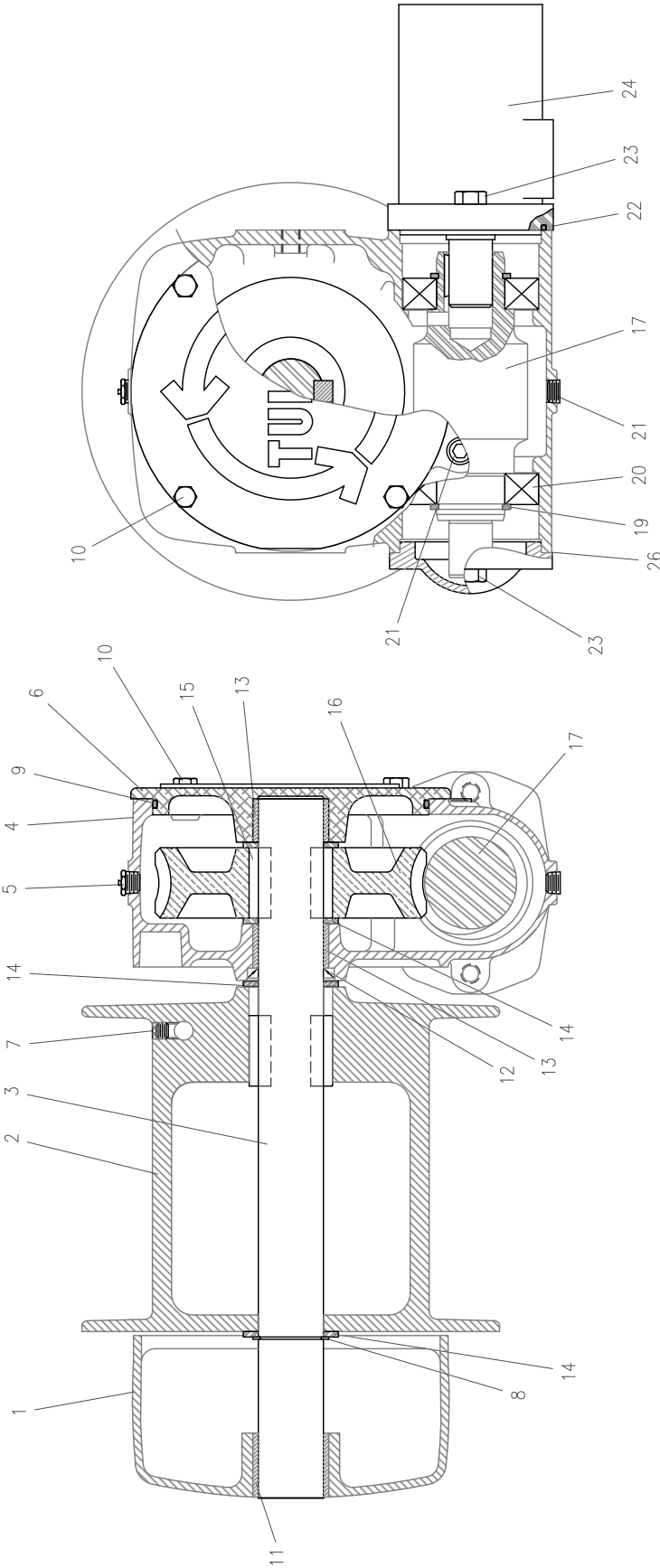

#	PN	DESCRIPTION	QTY	#	PN	DESCRIPTION	QTY	#	PN	DESCRIPTION	QTY
1	TW*40955	END BRACKET, MACH	1	10	TW*40407	CAPSCREW	4	19	TW*40396	RING, RETAINING	2
2	TW*41310	DRUM	1	11	TW*40399	BUSHING	1	20	TW*40395	BEARING	2
3	TW*41311	SHAFT, OUTPUT	1	12	TW*40401	SEAL OIL	1	21	TW*32220	PLUG, PIPE	2
4	TW*40383	HOUSING	1	13	TW*40400	BUSHING	2	22	TW*32566	O-RING	1
5	TW*4101	BREATHER KIT	1	14	TW*29017	WASHER	4	23	TW*40410	CAPSCREW	2
6	TW*40391	COVER, MACH	1	15	TW*40518	KEY	4	24	17034	MOTOR, HYDRAULIC	1
7	TW*23582	SCREW-SET	1	16	TW*40618	GEAR, SR	1	25	TW*4034	KIT, BRAKE, OIL	1
8	TW*27240	RETAINING RING	1	17	TW*40598	WORM, SR	1	26	TW*40147	GASKET	1
9	TW*40547	O-RING	1	18	OMIT			27	TW*40940	SPACER	1

Houston TX  
(713)-688-5533  
www.liftmoore.com

**WINCH, HYD 3360 W/ MOTOR**

DRAWN BY: SJN  
DATE: 10/4/96

DRAWING NO.  
**32283-A**



**TO SET WINCH BRAKE:**

HOLD SCREW 8  
 LOOSEN LOCKNUT, 9  
 TURN SCREW 8 CW 1/4 TURN  
 CHECK FOR DRIFT

IF BRAKE DOES NOT HOLD, TURN  
 SCREW 8 CW IN 1/4 TURN  
 INCREMENTS UNTIL IT HOLDS

TIGHTEN JAMNUT, 9, WHEN FINISHED

DO NOT TIGHTEN MORE THAN  
 NECESSARY. OVER TIGHTNING  
 WILL CAUSE OVER HEATING AND  
 PREMATURE WEAR IN THE BRAKE

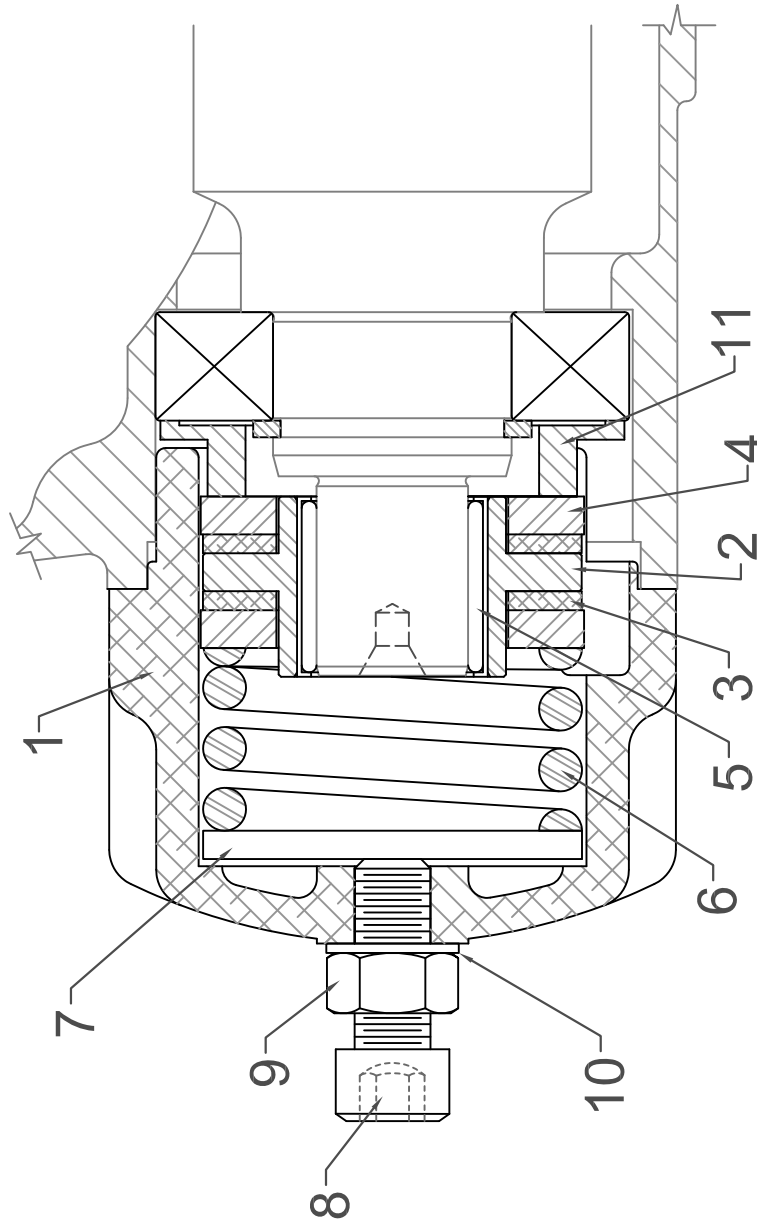

ITEM 12 NOT SHOWN

#	PN	DESCRIPTION	QTY	#	PN	DESCRIPTION	QTY	#	PN	DESCRIPTION	QTY
1	TW*40069	HOUSING	1	5	TW*40113	CAM CLUTCH	1	9	TW*40774	NUT	1
2	TW*40617	HUB	1	6	TW*40077	SPRING	1	10	TW*29044	WASHER	1
3	TW*40075	FRICITION DISC	2	7	TW*40078	TRUST WASHER	1	11	TW*40599	SPACER	1
4	TW*40076	STATOR PLATE	2	8	TW*40775	SET SCREW	1	12	TW*40546	CAPSCREW	2

		HOUSTON TX (713)-688-5533 www.liftmoore.com	DRAWN BY: SSC DATE: 11/14/94	WINCH BRAKE PARTS TW*4034	DRAWING NO. 50231-B
--	--	---------------------------------------------------	---------------------------------	---------------------------	------------------------

ITEM NO.	PART NUMBER	DESCRIPTION	QTY.
1	3309	SEAL, OIL #19831	1
2	AT3263	SEAL, OIL #12355PTC	1
3	AT3651	SNAP RING, INT. SHRI75STPA	1
4	AT4301-2E	HOUSING	1
5	AT4306A	CAP, GEAR	1
6	AT4309	CAP, WORM	1
7	AT4323A	7/16-14 X 1" HHCS PLATED	6
8	AT4327-2	SPACER, GEAR	1
9	AT4332SYP	SHIM, GEAR .003 GREEN	AS REQ.
9	AT4332SNP	SHIM, GEAR .005 BLUE	AS REQ.
9	AT4332SHP	SHIM, GEAR .0075 NATURAL	AS REQ.
9	AT4332SBP	SHIM, GEAR .010 BROWN	AS REQ.
10	AT4345G	GEAR, WORM 45i	1
11	AT4345X6	WORM 45i	1
12	AT4354	O-RING, PARKER 2-043	1
13	AT4354-2	O-RING, PARKER 2-165	1
14	AT4542SYP	SHIM, WORM .003 GREEN	AS REQ.
14	AT4542SNP	SHIM, WORM .005 BLUE	AS REQ.
14	AT4542SHP	SHIM, WORM .0075 NATURAL	AS REQ.
15	AT4552C & AT4552R	BRG, ROLLER CUP NP761714 & CONE NP535811	2
16	AT17595P	OUTPUT PINION	1
17	HCA3223F	3/8-16 x 1.1/8" LG HHCS	4
18	MA00140	MOTOR, HYD 4.74 CIPR 1" KEYED	1
19	PT8061C & PT8061R	BRG, ROLLER CUP-LM104911 & CONE-LM104949	1
20	SB1889	VENT. PRESSURE 1-5 PSIG	1
21	SB2671A	PLUG, PIPE 1/4" SOCKET HEAD	2
22	SB4563	OIL SEAL C/R 16084	1
23	SB4567	BUSHING, RED 1/8 X 1/4	1
24	SB4599C	GREASE FITTING 1/8 NPT 90	1
25	SC4523ES	1/2-13 X 1.1/4" SHCS	2
26	SH2161C & SH2161R	BRG, ROLLER CUP LM102910 & CONE LM102949	1
27	SH3297	PLUG, PLASTIC HOLE	4

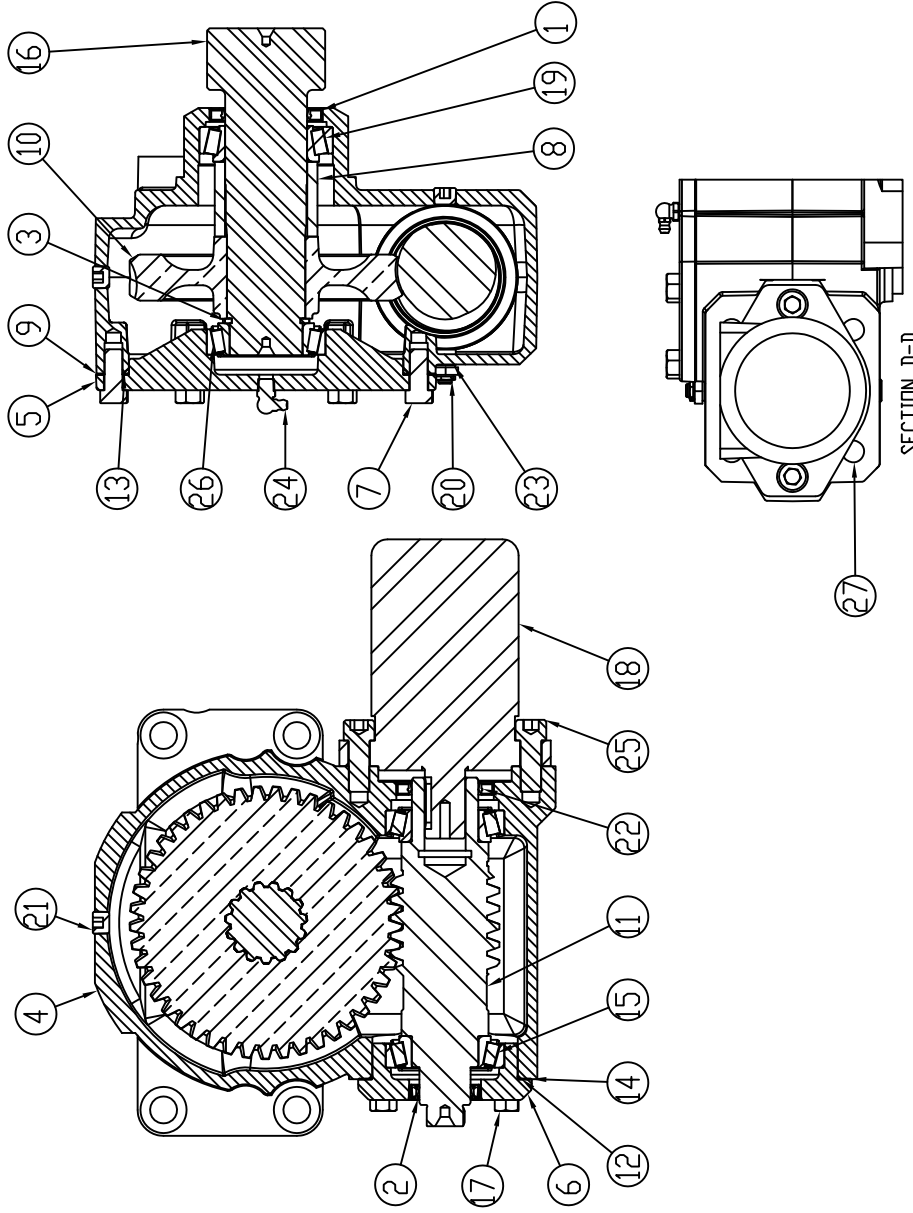

DRAWING NO.  
**27128-0**

**REDUCER, SPEED PERFECTION GEAR**  
PERF. GEAR P/N AT175955

DRWN BY: PER G  
DATE: 04/23/15

Houston TX  
(713)-688-5533  
www.liftmoore.com

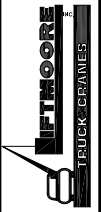

**NOTE A:**  
FOR J-14  
INSTALL 16GA. WHT PLUGS AT  
PIN LOCATIONS: J14-C, D; P6.6 &  
P12-B, 12

CIRCUIT NUMBER AND DESCRIPTION		
Wire Color	Wire Length	Function
BLU/BLK	30"	J14-A HORN OUTPUT
YEL	22"	J14-B TRIG GRND
WHT	12"	J14-E PWR, SOC
RED	32"	J14-F P2-R, 1 ROT CW
GRN	18"	J14-G P2-U, 1 ELEV UP
ORN	16"	J14-H P12A, 7 ELEV DWN
BLU	16"	J14-J P12A, 6 HOIST UP
WHT/BLK	16"	J14-K P12A, 2 TRIG SIG
RED/BLK	32"	J14-L P2-RA, 1 ROT CCW
GRN/BLK	18"	J14-M P12A, 8 EXT OUT
ORN/BLK	28"	J14-N P2-X, 1 EXT IN
BLK	26"	J14-P P2-H, 1 HOIST DWN
BRN	26"	P12A, 1 TR-2 GRND
YEL/BLK	26"	P12A, 3 P2-P, 1 PROP
GRY	18"	P12A, 4 P2-PS, 2 PRESS SW
BLK	18"	P12A, 5 P2-ATB, 2 ATB
WHT	34"	P12A, 9 P2-XA, 1 EXT. OUT VAL
YEL	36"	P12A, 10 P2-LA, 1 ELEV DWN VAL
PUR	32"	P12A, 11 P2-HA, 1 HOIST UP VAL
YEL	N/A	P6.1 MAIN PWR
RED	18"	P6.2 P12A, 12 POWER
RED	14"	P6.4 P2-ATB, 1 PWR, ATB
RED	14"	P6.5 P2-PS, 1 PWR, PS
GRN	24"	P2-U, 2 P2-L, 1 ELEV UP

BRN	P12B, 1 TR-2 MAIN GROUND
BRN	P12B, 2 P2-HA, 2 HOIST UP VAL GND
BRN	P12B, 3 P2-H, 2 HOIST UP VAL GND
BRN	P12B, 4 P2-L, 2 ELEV UP VAL GND
BRN	P12B, 5 P2-LA, 2 ELEV DWN VAL GND
BRN	P12B, 6 P2-X, 2 EXT OUT VAL GND
BRN	P12B, 7 P2-XA, 2 EXT IN VAL GND
BRN	P12B, 8 P2-RA, 2 ROT. CCW VALVE
BRN	P12B, 9 P2-R, 2 ROT. CW VALVE
BRN	P12B, 10 P2-P, 2 PROP GRND
BRN	P12B, 11 BF HORN GND

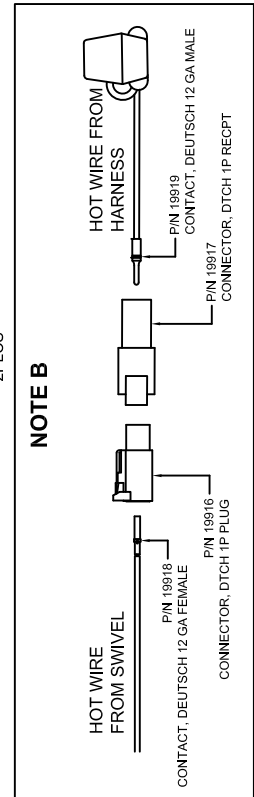
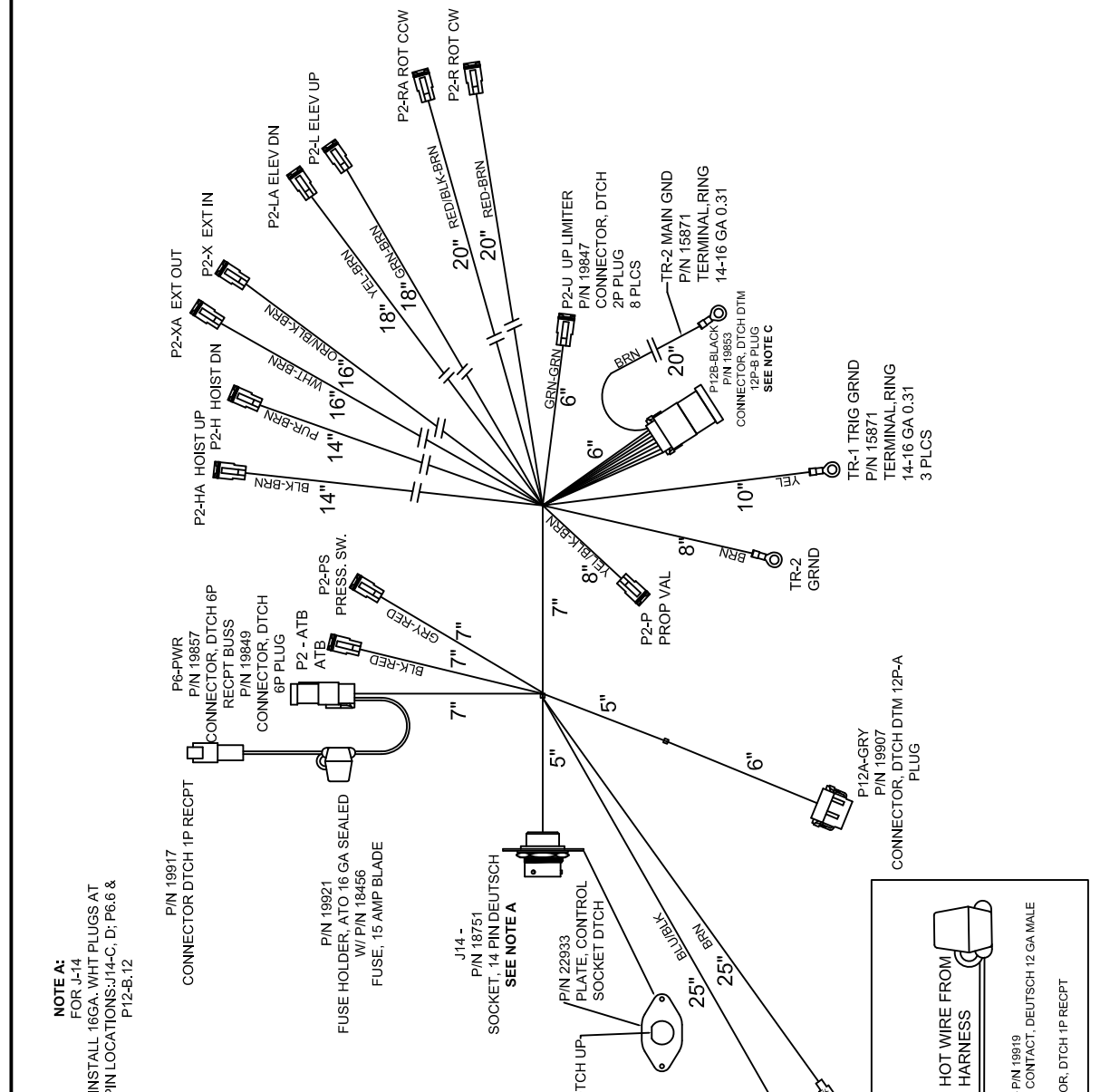

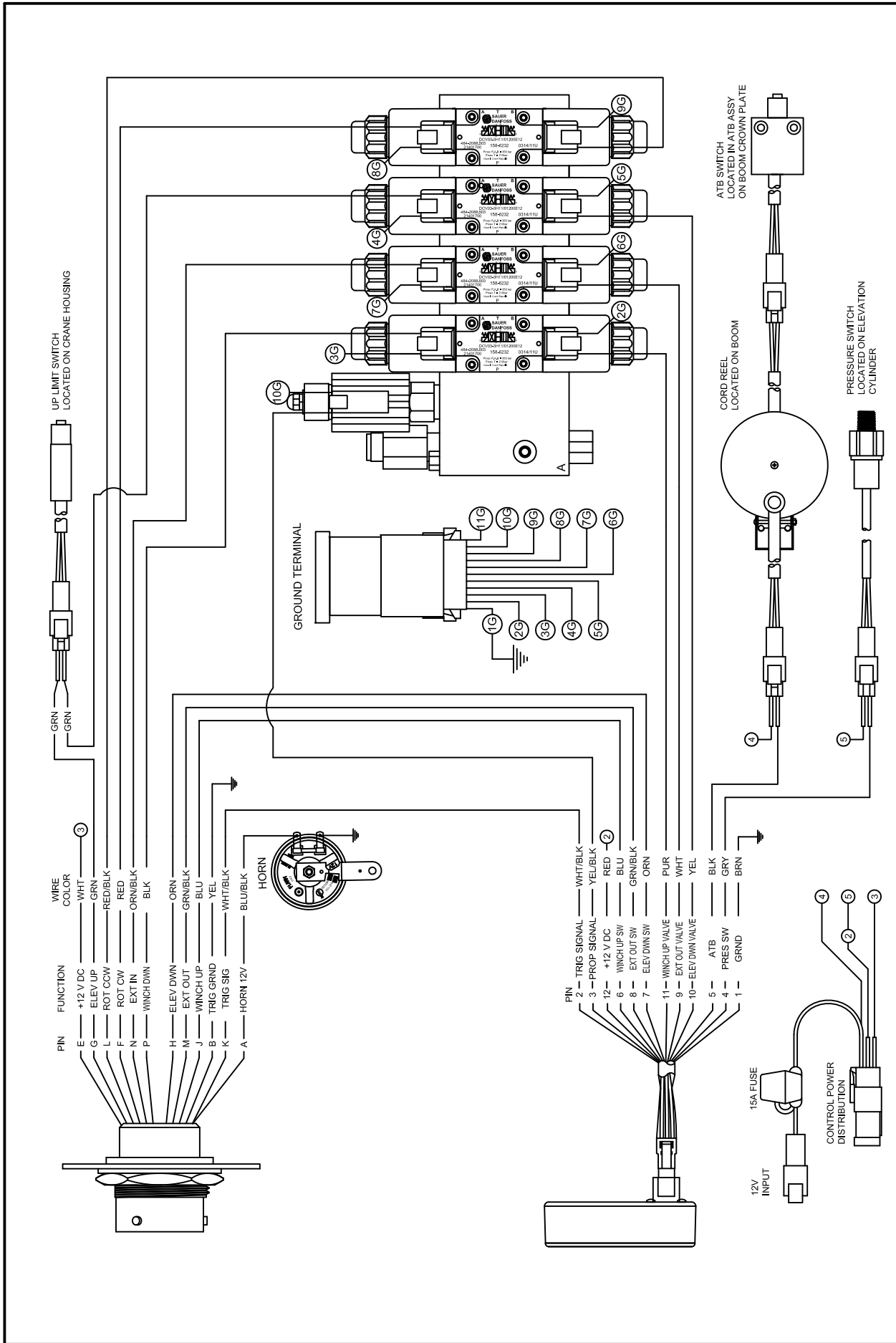

Houston TX  
 (713)-688-5533  
 www.iftmoore.com

DRWN BY: JE  
 DATE: 9/10/12

SCHEM, ELEC WIRING DTCH 3RD G XP ATB-BD  
 EWH 25125, HALL EFFECT, SD VAL

DRAWING NO.

50826-A

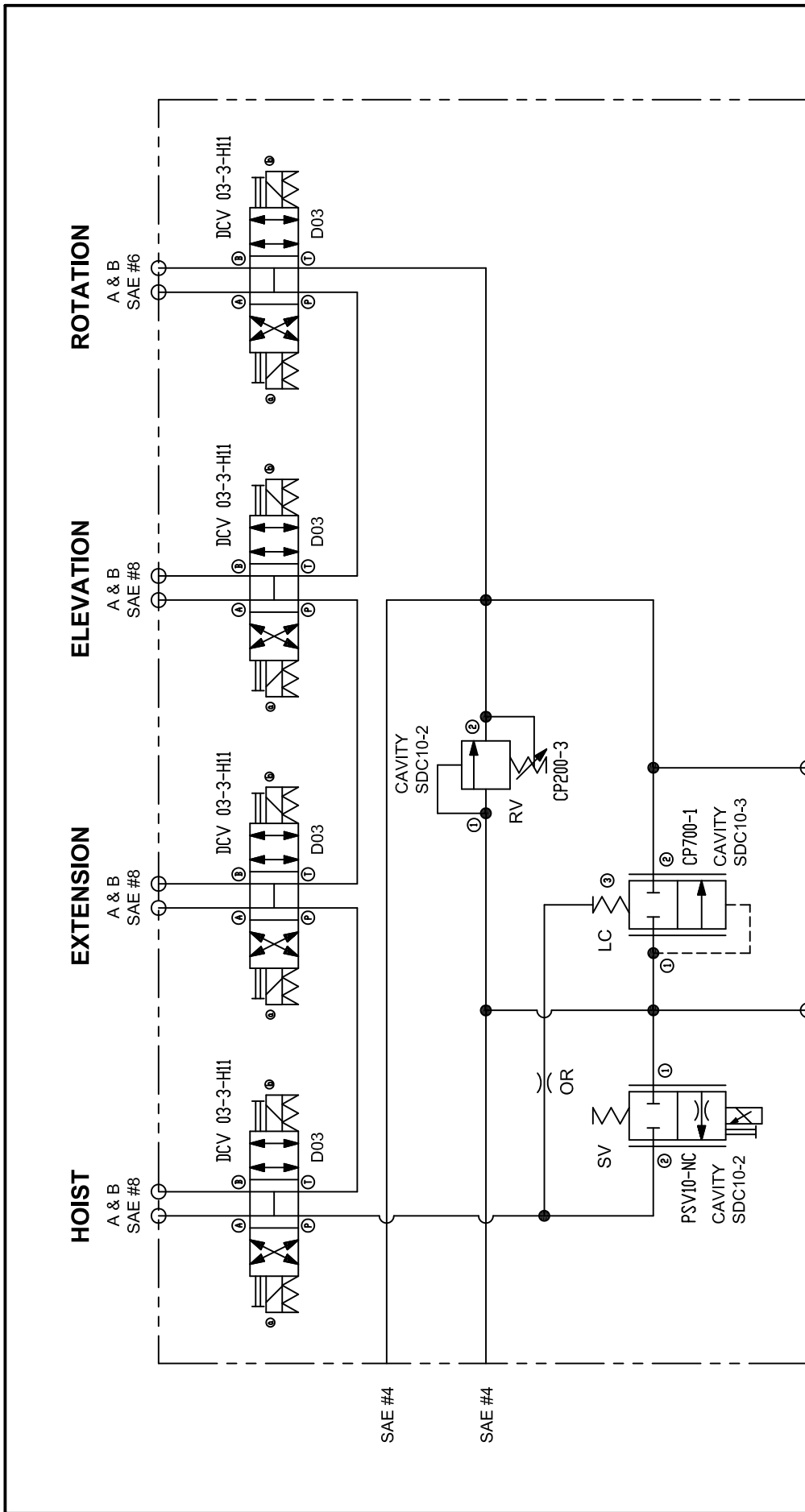

NOTE: HYDRAULIC SYSTEM RELIEF PRESSURE SET AT 2800 PSI.  
FLOW RATE INTO CRANE SHOULD BE SET AT 6 GPM.



Houston TX  
(713)-688-5533  
www.liftmoore.com

DRWN BY: JE  
DATE: 6/29/11

SCHEM, HYD PROPORTIONAL  
LIFTMOORE-MANIFOLD 24993

DRAWING NO.

50801-C

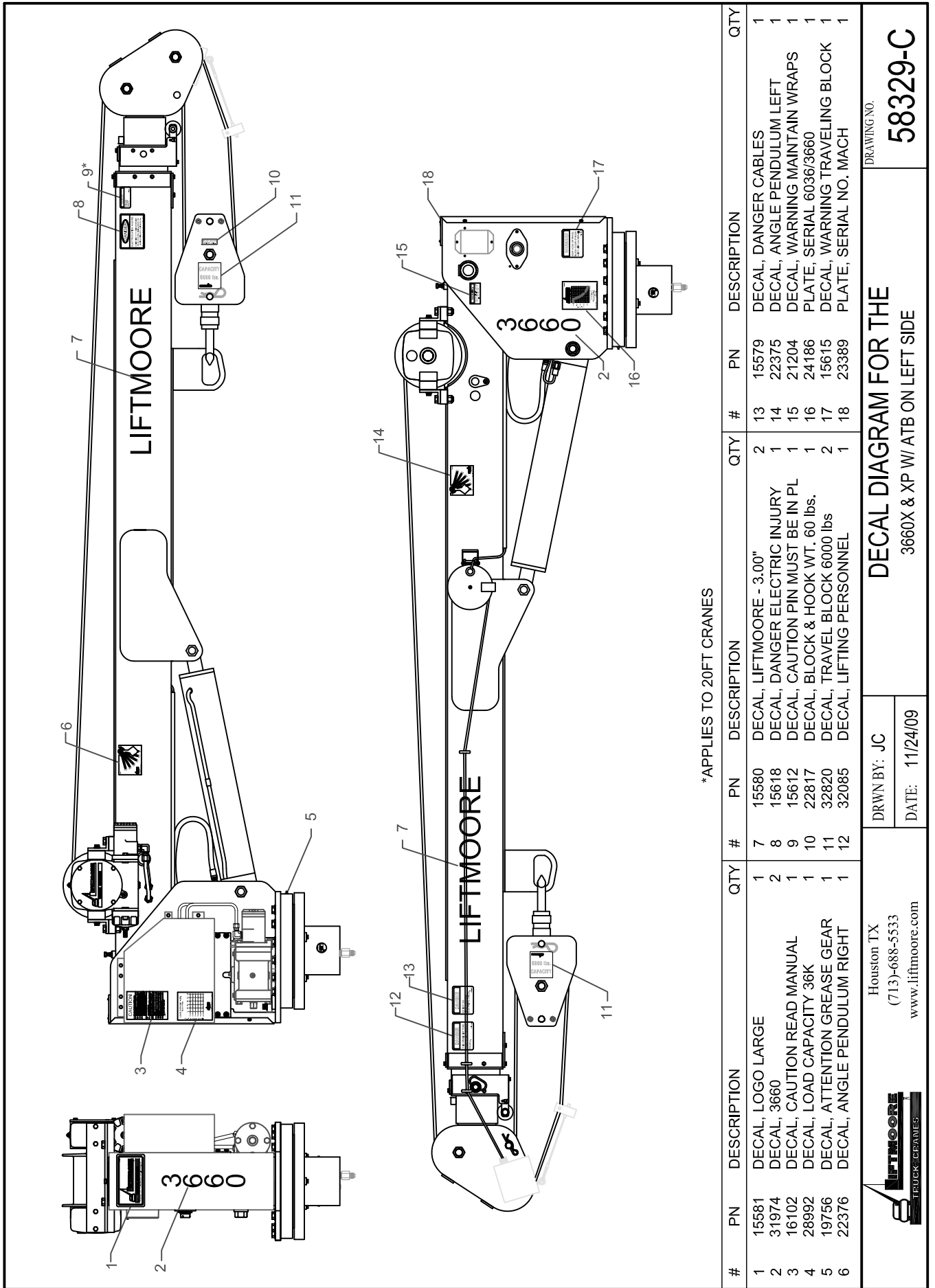

\* APPLIES TO 20FT CRANES

#	PN	DESCRIPTION	QTY	#	PN	DESCRIPTION	QTY	#	PN	DESCRIPTION	QTY
1	15581	DECAL, LOGO LARGE	1	7	15580	DECAL, LIFTMOORE - 3.00"	2	13	15579	DECAL, DANGER CABLES	1
2	31974	DECAL, 3660	2	8	15618	DECAL, DANGER ELECTRIC INJURY	1	14	22375	DECAL, ANGLE PENDULUM LEFT	1
3	16102	DECAL, CAUTION READ MANUAL	1	9	15612	DECAL, CAUTION PIN MUST BE IN PL	1	15	21204	DECAL, WARNING MAINTAIN WRAPS	1
4	28992	DECAL, LOAD CAPACITY 36K	1	10	22817	DECAL, BLOCK & HOOK WT. 60 lbs.	1	16	24186	PLATE, SERIAL 6036/3660	1
5	19756	DECAL, ATTENTION GREASE GEAR	1	11	32820	DECAL, TRAVEL BLOCK 6000 lbs	2	17	15615	DECAL, WARNING TRAVELING BLOCK	1
6	22376	DECAL, ANGLE PENDULUM RIGHT	1	12	32085	DECAL, LIFTING PERSONNEL	1	18	23389	PLATE, SERIAL NO. MACH	1



Houston TX  
(713)-688-5533  
www.liftmoore.com

DECAL DIAGRAM FOR THE  
3660X & XP W/ ATB ON LEFT SIDE

DRAWING NO.  
**58329-C**

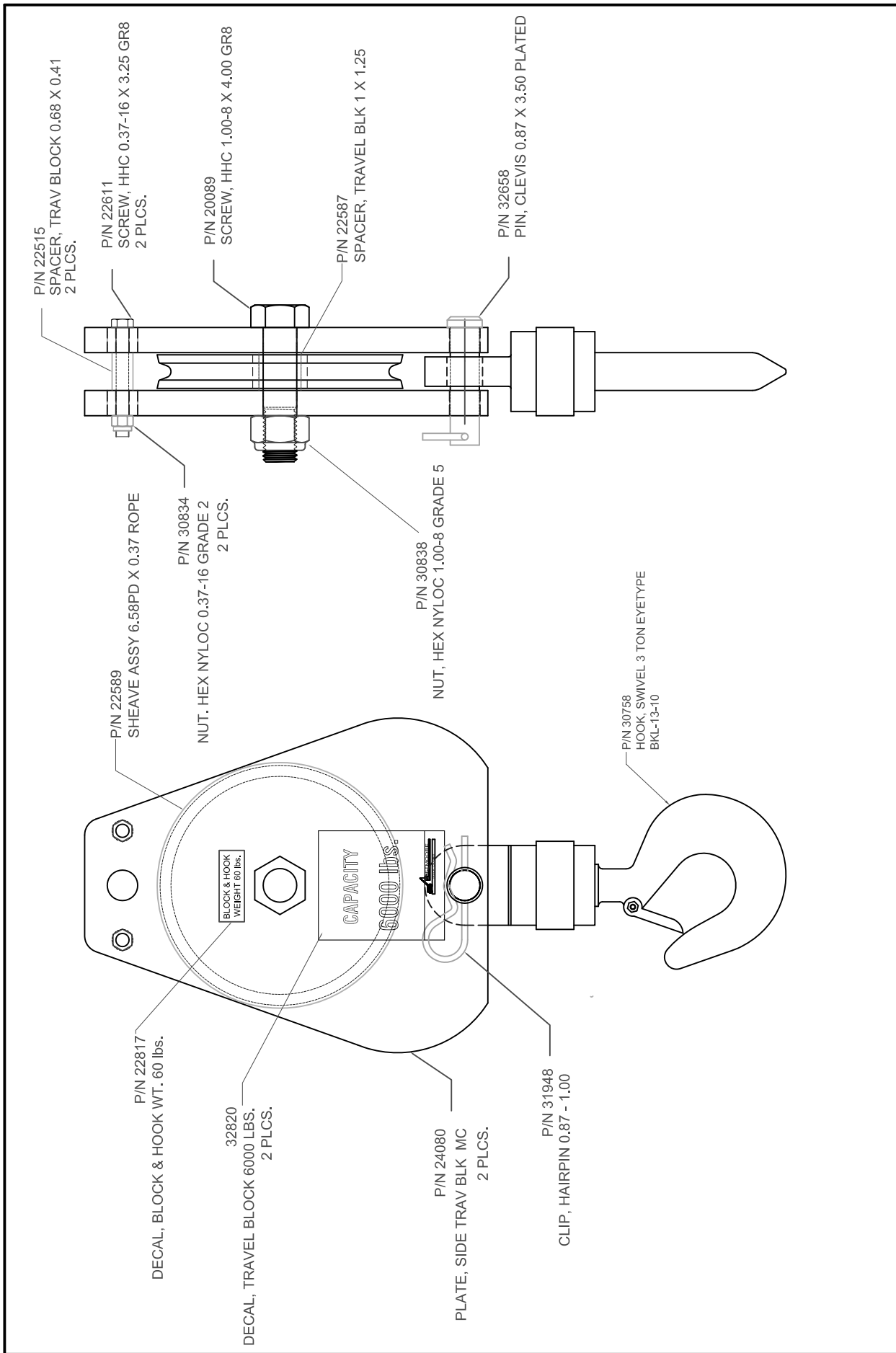

Houston TX (713)-688-5533 www.liftmoore.com	DRWN BY: PDS	BLOCK, TRAVEL ASSY 6.0K LBS/6.5D GUNNEBO HOOK P/N 24034	DRAWING NO. <b>24081-C</b>
	DATE: 10-11-10		



THIS DRAWING INTENTIONALLY LEFT BLANK

FOR FUTURE ADDITIONS

OR

A PART OR FEATURE IS NOT APPLICABLE TO THIS CRANE



Houston TX  
(713)-688-5533  
[www.iftmoore.com](http://www.iftmoore.com)

DRWN BY:

DATE:

DRAWING NO.



## **LIFTMOORE LIMITED WARRANTY**

### Parts and Structural

Liftmoore, Inc. warrants each LIFTMOORE crane to be free from defects in materials and workmanship for twelve (12) months from the date of delivery to the original customer. Under the terms of this warranty the crane structural components manufactured by LIFTMOORE, Inc. are warranted for thirty-six (36) months from the date of delivery to the original customer. LIFTMOORE, Inc. will repair or replace, as its sole discretion, any equipment or part that is returned f.o.b. to LIFTMOORE, Inc.'s plant at 7810 Pinemont Drive, Houston, Texas 77040, or to one of its authorized dealers, and is found by LIFTMOORE, Inc. or its authorized dealer to have been defective at the time of original delivery.

The foregoing warranty is the exclusive warranty made by LIFTMOORE, Inc. with respect to its cranes and is in lieu of all other warranties. ANY AND ALL OTHER WARRANTIES, EXPRESS OR IMPLIED, INCLUDING ANY WARRANTY OF MERCHANTABILITY OR FITNESS OF ANY CRANE FOR A PARTICULAR PURPOSE OR OPERATION, ARE HERBY EXPRESSLY DISCLAIMED.

The foregoing warranty applies only to LIFTMOORE cranes under normal use and service and does not apply in the event of damage caused by repair or alteration or damage during shipment, accident, negligence, overloading, or misuse, including operator's failure to follow any of the instructions issued with the crane.

This warranty is limited to the original purchaser and is not assignable. In order to submit a claim, the original purchaser must provide a copy of the original invoice for the crane in question within twelve (12) months following the delivery date and within 30 days from the date of repair.

The warranty applies only when the LIFTMOORE crane is used for commercial purposes and does not cover any purchase for use for personal, family or household purposes.

**LIMITATION OF LIABILITY:** LIFTMOORE, Inc.'s liability for any losses or damages resulting from any cause whatsoever, including LIFTMOORE, Inc.'s NEGLIGENCE or from a defective crane irrespective of whether such defects are discoverable or latent, shall in no event exceed the purchase price of the crane to which losses or damages are claimed, or at the election of LIFTMOORE, Inc., the repair or replacement of the defective crane.

In no event shall LIFTMOORE, Inc. be liable for any special, incidental, or consequential damages, including commercial losses or costs of any kind sustained by purchaser or any other person or for any damages for which purchaser may be liable to other persons by reason of any defect in any LIFTMOORE crane or any part thereof.

LIFTMOORE, Inc. reserves the right to make changes in design or construction of its cranes at any time without obligating itself to make such changes on cranes previously manufactured.

No agent, employee, or representative of LIFTMOORE, Inc. has authority to amend or modify the foregoing warranty or to bind LIFTMOORE, Inc. by any other warranty, guaranty, or assumption of liability.

In the event any provision of this warranty is for any reason held ineffective, the remaining provisions shall remain in full force and effect.

Some states do not allow limitations on how long an implied warranty lasts or the exclusion or limitation of incidental or consequential damages, so the above limitations and exclusions may not apply to you. This warranty gives you specific legal rights, and you may also have other legal rights that vary from state to state.

