

# TABLE OF CONTENTS

USERS MANUAL P/N 28981  
3612 WP DTCH MONARCH.  
15 FT BOOMS

## SECTION I

### CRANE INSTALLATION INSTRUCTIONS

CRANE INSTALLATION INSTRUCTIONS .....	F2526-A .....	1-1
MOUNTING PATTERN.....	50895-0 .....	1-3
ELECTRICAL INSTALLATION .....	50912-0 .....	1-4
STABILITY PROCEDURE.....	F691-G .....	1-5
STABILITY TEST RESULTS .....	F691-G .....	1-6

## SECTION II

### GENERAL OPERATION, INSPECTION, AND MAINTENANCE

CRANE SAFETY RULES.....	F1122-B.....	1-7
INTRODUCTION .....	F1111-D.....	1-8
OPERATING RESTRICTIONS .....	F1112-E.....	1-9
OPERATING PRACTICES.....	F1112-E.....	1-10
INSPECTION AND MAINTENANCE.....	F1113-D .....	1-12
MONTHLY INSPECTION REPORT .....	F1123-B.....	1-14
STANDARD HAND SIGNALS FOR CRANE OPERATIONS ..	F2409-0.....	1-15

## SECTION III

### WIRELESS REMOTE CONTROL SYSTEM GUIDER

OPERATION MANUAL RADIO/CAN REMOTE .....	3B2781J .....	1-19
---	---------------	------

## SECTION IV

### CRANE SYSTEMS AND TROUBLESHOOTING

SAFETY SYSTEM.....	F1115-F .....	2-1
ELECTRIC HOIST.....	F1239-0 .....	2-2
HYDRAULIC SYSTEM FOR ELECTRIC CRANE .....	F1145-D .....	2-3
TROUBLESHOOTING SAFETY SYSTEM .....	F1254-A .....	2-5
TROUBLESHOOTING ELECTRIC HOIST .....	F1243-A .....	2-6
TROUBLESHOOTING HYRAULIC PUMP .....	F1255-B .....	2-8
DEUTSCH CONNECTIONS & PINS .....	F2435-A .....	2-9

## SECTION V

### CRANE SPECIFICATIONS

LIFTING CAPACITIES .....	F2614-0 .....	3-1
POWER FUNCTIONS AND SPEEDS.....	F2614-0 .....	3-1
BOLT AND LUBRICATION SPECS .....	F2614-0 .....	3-2
CRANE LUBRICATION POINTS.....	F2614-0 .....	3-3



F2610-A  
1/28/20

HOUSTON, TEXAS  
FAX: (800) 824-5559 (USA & Canada)  
FAX: (713) 688-6324  
PHONE: (713) 688-5533  
[www.liftmoore.com](http://www.liftmoore.com)

# TABLE OF CONTENTS

USERS MANUAL P/N 28981  
3612 WP DTCH MONARCH.  
15 FT BOOMS

## SECTION VI PARTS

BOX PARTS LIST .....	F2611-0 .....	4-1
CRANE ASSEMBLY .....	DWG.28951-B .....	4-2
CRANE ASSEMBLY II .....	DWG.28579-F .....	4-7
ANTI-TWO BLOCK ASSEMBLY .....	DWG.22908-B .....	4-10
BOOM-BODY ASSEMBLY .....	DWG.28630-C .....	4-11
ELEVATION CYLINDER ASSEMBLY .....	DWG.21209-C .....	4-12
BODY ASSEMBLY .....	DWG.28629-C .....	4-13
MANIFOLD ASSEMBLY .....	DWG.22168-B .....	4-18
HYDRAULIC PUMP .....	DWG.50624-H .....	4-19
BASE-HOUSING ASSEMBLY .....	DWG.28626-D .....	4-20
ROTATION COMPONENTS .....	DWG.50706-A .....	4-22
ELECTRIC SWIVEL .....	DWG.50754-0 .....	4-23
BOOM ASSEMBLY – 15 FT .....	DWG.28568-B .....	4-24
BOOM INNER ASSEMBLY – 15 FT .....	DWG.22937-B .....	4-26
WINCH DRAWING .....	DWG.23872-C .....	4-27
WINCH PARTS LIST .....	DWG.23872-C .....	4-28
ELECTRICAL WIRING HARNESS .....	DWG.28919-D .....	4-29
ELECTRICAL SCHEMATIC .....	DWG.50916-C .....	4-30
TRAVEL BLOCK ASSY .....	DWG.22532-D .....	4-31
WARRANTY .....	F1442-A .....	



F2610-A  
1/28/20

HOUSTON, TEXAS  
FAX: (800) 824-5559 (USA & Canada)  
FAX: (713) 688-6324  
PHONE: (713) 688-5533  
[www.liftmoore.com](http://www.liftmoore.com)

## MODEL 2010/3612 INSTALLATION INSTRUCTIONS

Read and understand this complete section before starting the crane installation.

Before installing make sure you have all necessary parts. Please refer to the Owner's manual Section 4-1 for the list of parts required for installation. Report any shortages to Liftmoore, Inc. immediately.

1. The mounting must be adequate to support the load and moment rating for the crane as listed:  
2010 - 2,000 Lbs. Maximum Load; 10,000 Ft.-Lbs. Moment Rating

For truck mounting the crane must be mounted on a structure that will carry the loads to both sides of the truck frame. Sample mounting instructions are available from Liftmoore upon request.

2. Layout the mounting holes for the crane as shown in the drawing No. 50895 in this manual. The base plate for this crane is 14" square with holes for four 1/2" bolts on a 12" square pattern. Drill four 9/16" mounting holes to match the 12" square pattern. Cut a 5.0" hole in the center of the mounting to clear the portion of the quill that projects through the base plate. On cranes with auxiliary controls in the pendant, the rotation is restricted. For these models, locate the rotation stop opposite the point where the boom will be restricted. Bolt the crane onto the truck using the 1/2" x 2-3/4" Grade 8 bolts supplied. If longer bolts are required, at least Grade 8 quality is needed. Tighten the 1/2" Grade 8 bolts to 120 Ft.-Lbs. Other bolts can be used if they are at least Grade 8 strength and no less than 1/2" diameter.(1/2-13 GRADE 8)

NOTE: Replace the plug in the reservoir with the filler-breather plug shipped with the box of crane parts.

3. A manual disconnect switch with mounting bracket and terminals is provided with the crane. This switch will act as the main power disconnect for the crane. Removing power from the crane during periods of non-use will help to increase the life of the crane's electrical components. The switch should be mounted as near as possible to the crane and in a position which will facilitate its use. Determine the appropriate mounting position for the switch and use the supplied terminals to splice in to the crane's main power cable. We recommend that this be below the welding connector supplied with the crane. Drawing No. 50912 illustrates where we recommend installing the disconnect switch, welding connector and circuit breaker.(Always turn off power when crane is not in use.)

4. The vehicle's battery should have a capacity of at least 90 Amp-Hr. A second battery located near the crane is strongly advised (Refer to drawing 50912 FIG.1). This will keep the voltage as near 12 Volts as possible while the crane is running. The life of the crane's electrical components will be longer if the voltage is as near 12 volts as possible. A deep cycle battery provides the best battery life. Connect the second battery in parallel with the truck's original equipment battery using at least No. 1 battery wire.

5. Install the 150 Amp circuit breaker near the battery supplying the crane and on the battery's positive line with a universal or marine type wing nut lug terminal (See drawing 50912 FIG.1). This breaker is to protect the battery in event of an accidental grounding of the positive wire anywhere along its length. Use a section of the wire and the terminals supplied to connect between the battery and the circuit breaker. See drawing No. 50912.

6. Run the No. 1 battery cable along the inside of the chassis frame to the circuit breaker if a second battery is not used. Make sure that the cable is protected avoiding sharp edges and heat sources such as the muffler or catalytic converter. Use loom for protection whenever the cable passes through the body, frame or other metal objects. The quick disconnect under the crane



**MODEL 2010/3612 INSTALLATION INSTRUCTIONS, Cont.**

should be accessible. Always leave this disconnected to take the crane out of the electrical circuit when it is not in use.

7. Install the extra ground wire P/N 26084 supplied from the negative battery terminal to the truck's main frame. Grounding the battery to the frame protects the chassis wiring. Leave the regular ground to the engine as is. The battery end of both wires can be clamped together using a universal type battery connector. This ground must be in place to protect the truck's wiring and for efficient operation of the crane. A good ground must exist for the crane to work. Leaving this ground wire off can damage the truck's chassis wiring as it may then carry some of the crane circuits current. This wire must be as large as the battery lead wire for the system to operate efficiently. (Refer to drawing 50912)

8. Attach ground wire P/N 28643 coming from the crane base directly to the negative terminal of battery (if battery is underneath crane see drawing 50912 FIG.1). Or attach to the truck's main frame (if battery is located in the engine compartment see drawing 50912 FIG.2).

9. A boom support must be installed to secure the boom when the truck is moved. Mount an eye on the boom rest for the hook as shown in Liftmoore's Accessories bulletin. The wire rope can then be used to secure the boom in the rest.

10. An outrigger must be installed to keep the truck and the crane as level as possible under all expected working conditions. Keeping the crane level reduces the loads on the rotation gear. This will also protect the truck's springs, axle and wheels when heavy loads are suspended from the crane. OSHA requirements require a stability test be performed on this installation. If the installation does not pass the stability test contact Liftmoore for information on derating the crane in the unstable areas.

11. Additional truck springs may be necessary depending upon the size of the truck and location of the crane on the truck. Add springs to bring the truck level after all equipment is mounted.

12. The crane is now ready to use. Read the Operating Instructions section of the Owner's Manual before operating the crane. When operating the crane for the first time run the cylinders through their full extension cycle to purge any air from the cylinder. Operate the crane to assure complete operation of all functions.

Operating speeds are approximately as follows:

Rotation of one revolution: 70 Seconds  
 Boom Elevation (75 Degrees): 35 Seconds  
 Boom Extension (6 Feet): 35 Seconds  
 Winch Line Speed: 17 Ft. per Min.

13. If equipped with an anti two-block device, verify that the anti two-block will stop extension out, boom down and winch up when the weight on the device is lifted by either function. Make sure that the weight is on the live or running wire rope. The Crane Assembly drawing in the owner's manual Section 4-2 illustrates how the weight should be installed on the line.

14. Place these Installation Instructions and the Owner's Manual with Operating Instructions in a convenient place for the user to find and use before operating the crane.

15. When complete, turn off the crane power switch and disconnect the welding connector.

14. Load Chart Decal is to be placed on the truck body for easy visibility by the user.



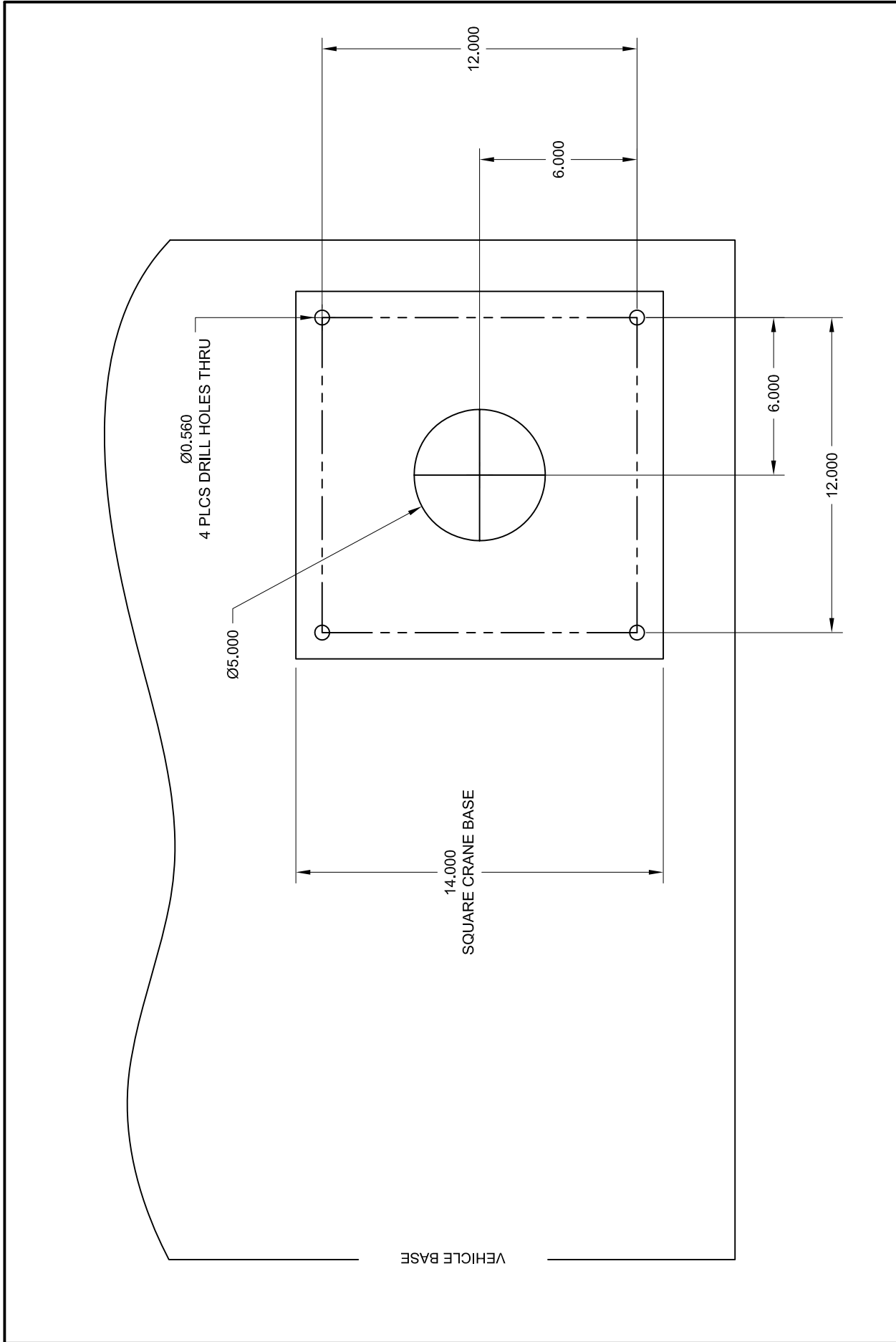

DRAWING NO. 50895-0

MOUNTING PATTERN FOR 2010

DRWN BY: JE  
DATE: 1/3/18

Houston TX  
(713)-688-5533  
www.liftmoore.com



FIG.1 SUGGESTED WIRING SCHEMATIC FOR UNDERNEATH CRANE.

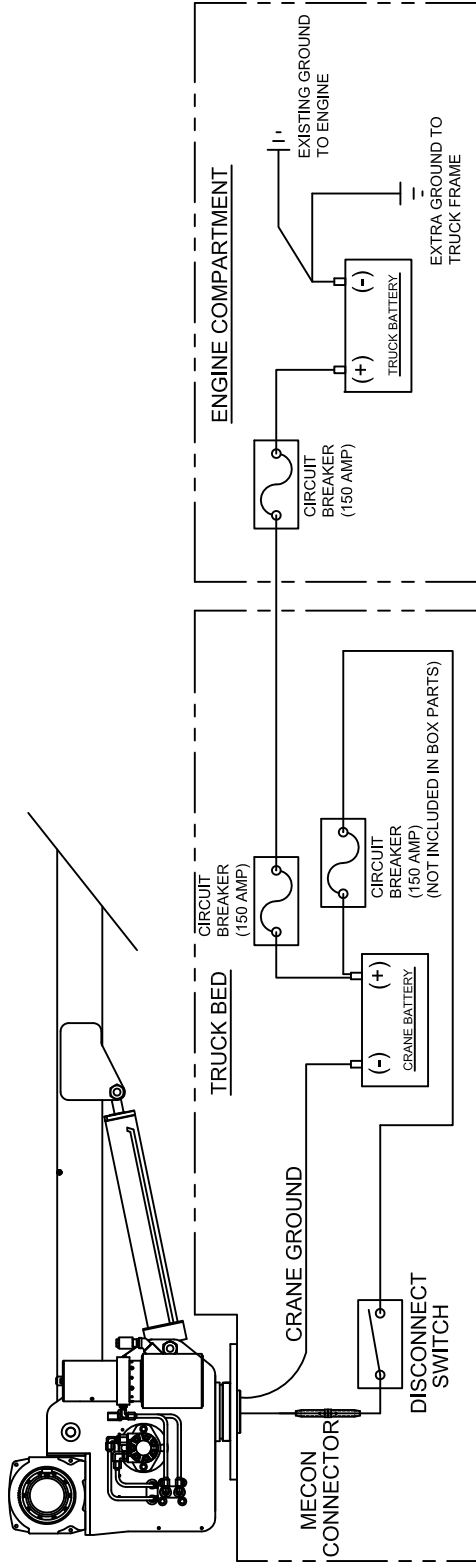
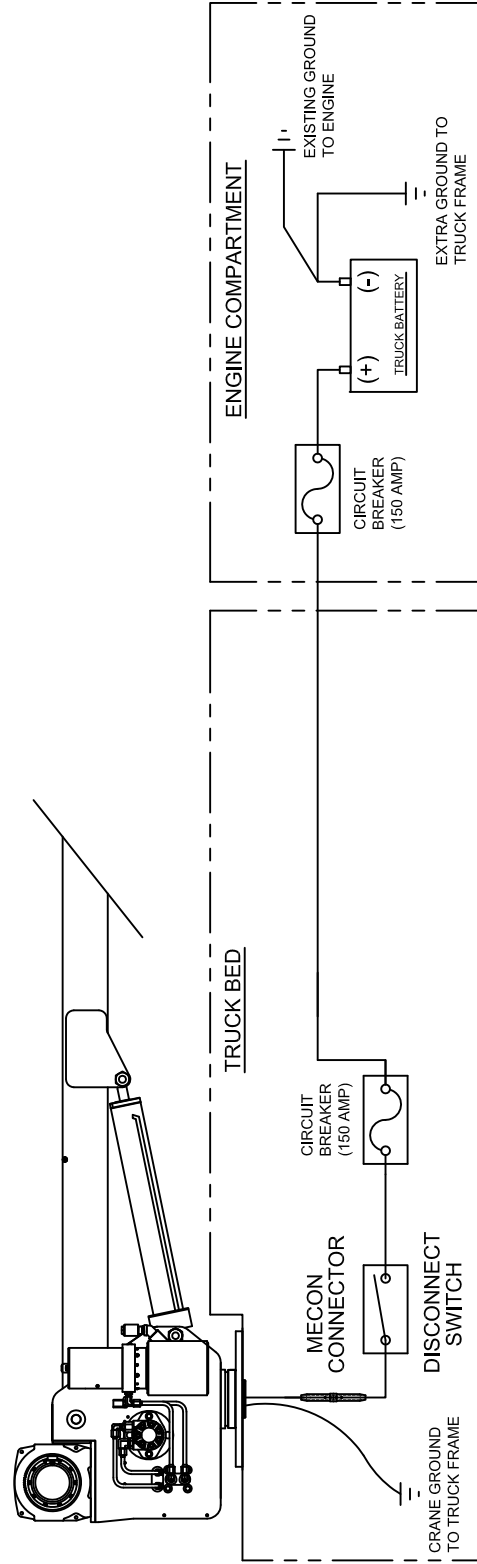

FIG.2 SUGGESTED WIRING SCHEMATIC FOR BATTERY IN ENGINE COMPARTMENT



Houston TX  
(713)-688-5533  
www.liftmoore.com

DRWN BY: JE  
DATE: 3/1/19

SCHEM, CRANE ELEC. INSTAL-ELEC

FOR 2010, 3612

DRAWING NO.

50912-0

## VEHICLE STABILITY TEST

12/6/12

Liftmoore, Inc.  
Form No. 691-G  
Revised 1/30/2013

OSHA requires a stability test be completed by the installer. A qualified person shall perform this test. Please call Liftmoore for any assistance required in completing this test.

### Test Preparations:

- Use as level of a test site as possible.
- Engage parking brake on vehicle.
- Set outriggers, jackstands, or other stability device in place.
  - Vehicle tires should remain in contact with the ground.
  - The vehicle should be level.

### Fill out test form:

- Complete the vehicle and crane data at the top of Page 2 of this form.
- Use a known weight to determine the *Testing Load Radius*.

### Test Procedure:

#### **Determine Area W1 Length**

1. With the crane extended to the *Testing Load Radius* over the rear of the truck, lift the load. Keep the load less than 4" off of the ground.
2. Rotate the load counterclockwise. Monitor all vehicle tires to ensure they remain in contact with the test surface.
3. When one of the vehicle's tires breaks contact with the ground, stop the rotation.
4. Use a protractor to determine this angle. Write this angle on the Stability Test Results as *Area Y*.
5. Keeping the load off of the ground, retract or elevate the boom until all tires are in contact with the test surface.
6. Continue rotating the load counterclockwise while monitoring all vehicle tires.
7. When one of the vehicle's tires breaks contact with the ground, stop the rotation.
8. Keeping the load off of the ground, retract or elevate the boom until all tires are in contact with the test surface.
9. Repeat this procedure until either the vehicle prevents further rotation or a 180 degree rotation of the load is reached.
10. Record the load radius in feet at this point on the Stability Test Results as *Area W1 Length*.

#### **Determine Area W2 Length**

11. Return the load to the rear of the vehicle and extend the load to the *Testing Load Radius*. Keep the load less than 4" off of the ground.
12. Rotate the load clockwise. Monitor all vehicle tires to ensure they remain in contact with the test surface.
13. When one of the vehicle's tires breaks contact with the ground, stop the rotation.
14. Use a protractor to determine this angle and write this angle on the Stability Test Results as *Area Z*.
15. Keeping the load off of the ground, retract or elevate the boom until all tires are in contact with the test surface.
16. Continue rotating the load clockwise while monitoring all vehicle tires.
17. When one of the vehicle's tires breaks contact with the ground, stop the rotation.
18. Keeping the load off of the ground, retract or elevate the boom until all tires are in contact with the test surface.
19. Repeat this procedure until either the vehicle prevents further rotation or a 180 degree rotation of the load is reached.
20. Record the load radius in feet at this point on the Stability Test Results as *Area W2 Length*.

#### **Record Stability Test Results on Placard**

21. Record the information from the Stability Test Results on the CRANE TRUCK STABILITY plate (P.N. 18600) and install the plate in a visible position on the vehicle, preferably near the crane.

**THIS TEST IS NOW COMPLETE**

1-6

## STABILITY TEST FORM

Operational limits of this vehicle

VEHICLE INFORMATION	CRANE INFORMATION
Year _____	Model _____
Make _____	Serial Number _____
Model _____	Moment Rating (ft-lbs.) _____
VIN _____	

Determine The **Testing Load Radius** by using the following:

Moment Rating (ft-lbs.) \_\_\_\_\_  
 Multiply by 1.18 x \_\_\_\_\_  
 Divide by known weight ÷ \_\_\_\_\_  
**Testing Load Radius (ft.)** = \_\_\_\_\_

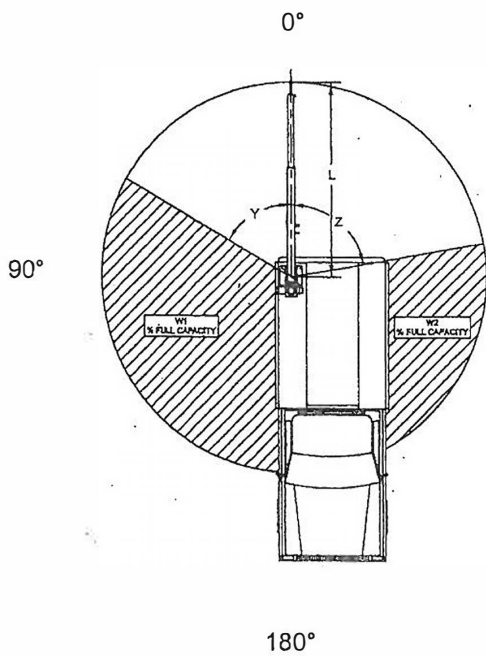

**Area W1 Length** \_\_\_\_\_  
**Testing Load Radius (ft.)** ÷ \_\_\_\_\_  
 Multiply by 100 x \_\_\_\_\_  
 W1 % Rated Capacity = \_\_\_\_\_

**Area W2 Length** \_\_\_\_\_  
**Testing Load Radius (ft.)** ÷ \_\_\_\_\_  
 Multiply by 100 x \_\_\_\_\_  
 W2 % Rated Capacity = \_\_\_\_\_

STABILITY TEST RESULTS	
Area Y:	_____ Degrees
Area Z:	_____ Degrees
Area W1 Rated Capacity:	_____ %
Area W2 Rated Capacity:	_____ %

Test performed by: \_\_\_\_\_

Date: \_\_\_\_\_



## CRANE SAFETY RULES

### CAUTION!

1. READ AND UNDERSTAND OPERATOR'S MANUAL.
2. INSPECT VEHICLE AND CRANE, INCLUDING ITS OPERATION BEFORE DAILY USE.
3. USE THIS EQUIPMENT ONLY ON SOLID LEVEL GROUND WITH OUTRIGGERS OR JACKSTANDS PROPERLY SET.
4. BEFORE OPERATING THE CRANE REFER TO MAXIMUM LOAD CHART ON CRANE FOR OPERATING LOAD LIMITS.
5. BE SURE LOAD BEING LIFTED IS WITHIN SAFE WINCH CAPACITY AS WELL AS SAFE CRANE CAPACITY. MULTI-PART LINE OPERATION IS REQUIRED WHEN SINGLE LINE LOAD CAPACITY OF WINCH IS EXCEEDED.
6. DO NOT OPERATE, WALK, OR STAND UNDER THE BOOM OR ANY SUSPENDED LOAD.
7. ALWAYS PAY OUT LOAD LINE BEFORE EXTENDING BOOM. WIRE ROPE DAMAGE AND / OR BREAKAGE MAY OCCUR.
8. BOOM MUST BE IN ITS REST BEFORE MOVING VEHICLE.
9. BOOM TIP MUST BE DIRECTLY OVER THE LOAD BEFORE ANY LIFTING IS STARTED. DO NOT DRAG LOADS WITH THIS CRANE.
10. MAINTAIN THIS CRANE AS REQUIRED IN THE OWNER'S MANUAL.
11. DO NOT ALLOW PERSONNEL TO RIDE ON THE LOAD LINE, LOAD, OR BOOM OF THIS CRANE.
12. IT IS UNLAWFUL TO OPERATE THIS EQUIPMENT WITHIN TEN FEET OF HIGH VOLTAGE LINE



## INTRODUCTION

This crane is a powerful machine designed to lift and move heavy loads. There are many hazards associated with these operations. Liftmoore has designed this crane to be as safe as possible but -

**IT IS THE OPERATOR'S RESPONSIBILITY TO PREVENT ACCIDENTS!**

This takes pre-planning, attention, and knowledge of basic principles and rules. Even if you have used similar cranes, reading this manual in its entirety will help prevent damage, injury, or even loss of life; benefits well worth the short amount of time it takes to read these pages.

### REGULATORY AUTHORITY

Use of this crane is governed by OSHA 29 CFR 1910.180 and may be governed by other federal, state, or local regulations.

**IT IS THE OPERATOR'S RESPONSIBILITY TO UNDERSTAND AND COMPLY WITH ALL APPLICABLE REGULATIONS GOVERNING THE OPERATION, INSPECTION, AND MAINTENANCE OF THIS CRANE.**

Personnel should be trained, tested, and certified, as recommended by OSHA and ANSI standards, before operating this crane.

### USING THIS MANUAL

This manual assumes that the crane is mounted on a typical service body type or similar truck, which is powered by the vehicle electrical or hydraulic system, and is controlled by either the standard pendant control or FM radio control sold by Liftmoore, Inc.

This manual is supplied to provide basic guidelines for the safe use, routine maintenance, and general inspections of this crane.

This manual is supplied to provide basic guidelines for the safe use, routine maintenance, and general inspections of this crane.

Laws, regulations, standards, or policies may be more restrictive than this manual. If a conflict exists for any limit or condition, the safest or most prohibitive shall be used. Under no circumstances shall the load, moment, or stability ratings be exceeded.

Pay particular attention to the following:

**WARNING!** – Draws attention to hazards, conditions, or procedures that if not observed could result in injury or death.

**CAUTION!** – Draws attention to hazards, conditions, or procedures that if not observed could result in damage to the crane, load, or other equipment. Equipment failure could in turn lead to injury or death.

**NOTE!** – Draws attention to conditions or procedures that are essential to emphasize.

For questions, interpretations, or to report errors, please contact Liftmoore, Inc, Engineering Dept.



## OPERATING PRACTICES

### OPERATING RESTRICTIONS

#### DUTY CYCLE

For Electric Cranes the duty cycle time should be limited to 10%. This is limited by heat buildup in the motors and declining charge in the batteries. (Installing extra batteries near the crane helps keep the voltage at maximum.)

#### PERSONNEL

LIFTING OR MOVING OF PERSONNEL IS STRICTLY PROHIBITED! This crane was neither designed nor intended to lift personnel. Under no circumstances should anyone be allowed to ride on the crane, line, or load. All non-essential personnel must be kept away when using the crane. The load must never be moved over people, nor must anyone be allowed to pass or stand under a suspended load.

#### ELECTRICAL LINES

Consult ANSI B30.5 for operating procedures, minimum safe distances, and prohibited zones when working around electrical lines or poles.

When operating near electrical power lines, the crane must be positioned so that the distance from the crane to the lines or poles is equal to or greater than the length of the fully extended boom plus the minimum safe distance required.

All parts of the crane, line, and load must be kept a minimum safe distance from electrical power lines and poles. This distance is 10 feet for electrical lines carrying 50kV or less.

UNDER NO CIRCUMSTANCES SHOULD A CRANE BE OPERATED UNDER ELECTRICAL POWER LINES.

#### SETUP

**POSITION** The vehicle must be positioned so that the load is kept as close to the crane base as possible to reduce the moment on the crane. Consideration must be given to starting and ending position as well as firmness and slope of the ground and any obstructions.

**OUTRIGGERS** The outriggers or jackstands must be firmly set and the vehicle as level as possible. This will reduce the stresses on the rotation drive and keep the load off the vehicle's suspension. Keep in mind that the weight on the vehicle will shift as the crane and load is rotated.

**MANUAL BOOM EXTENSION** If the manual extension part of the boom is needed, it must be extended and the boom pin placed in the required position. Insert the pin and replace the pin's hairpin keeper before attempting to lift any load.

**LOAD LIMIT** The operator must understand the crane load chart. The operator must ensure that the load is within the load limits over the entire range which it will be moved. Be sure to include the weight of any lifting devices including the travel block.

The load limit chart is attached to the side of the crane to aid the operator.

The boom angle indicator and chart aids the operator in determining the load capacity at various boom angles and extensions. It also gives the load limit at that configuration.

**STABILITY** A stability chart must be posted near the crane. The operator must understand the stability chart. The crane may be de-rated over some areas of its operating radius.



## 1-10

**TRAVEL BLOCK** The operator must determine if the load is within the single line compatibility of the winch or if a multi-part line configuration is needed.

**REEVING** Ensure the proper routing of the rope through the sheaves and travel block. The rope must lie in the sheave groove and must not rub against any metal objects.

Ensure the rope is correctly wound on the winch drum. The crane assembly drawing will indicate if the rope must be wound over the top or bottom of the drum. The rope must never contact any part of the winch mounting.

### WARNING!

If the winch winding direction is reversed the brake will not work and the load will fall.

### ATTACHING THE LOAD

**POSITION** The boom tip must be moved over the load before lifting so that it will be lifted straight up.

### CAUTION!

Never drag a load with the crane. Dragging a load puts very high stresses on the crane for which it was not designed.

**ROPE** Check the rope condition to ensure it is not frayed or damaged. Ensure that the rope is not kinked and that it does not contact any sharp edges or make any sharp bends.

If using double line configuration, ensure that the lines are not twisted.

### CAUTION!

Never wrap the hoist rope around the load! Serious damage to the rope WILL occur.

**HOOK** Always make sure the load is applied to the throat of the hook. Never use a bent hook.

### CAUTION!

Always lift with the throat of the hook. Never lift with the load applied to the tip of the hook. Doing so will bend the hook.

**SLINGS** If the load does not have a lifting eye, use a nylon, chain, or other type of sling designed for lifting and rated for loads greater than that being lifted.

**BALANCE** Ensure the load will be secure and balanced when lifted. Ensure that the load cannot shift in the sling and that the sling cannot slide across the hook should the load become unbalanced.

### LIFTING THE LOAD

Before lifting, ensure that the load is free from all mountings and is no way attached or stuck to anything.

Ensure that at least five full wraps remain on the winch drum at all times.

Test the winch brake by lifting the load a few inches and ensuring that it does not slip.



## HOLDING THE LOAD

The operator must keep the load in sight at all times once it is lifted.

The operator must never leave the controls once the load is lifted.

The operator must ensure that no one is allowed to pass or stand under a suspended load.

## CAUTION!

Never move the vehicle with a suspended load. Doing so will put dynamic loads on the crane for which it was not designed.

## MOVING THE LOAD

Before moving the load, make sure the path is free of any obstructions or people.

Avoid sudden accelerations or stops. Speeds must be kept to a minimum, especially rotation, to keep the load from swinging.

Avoid sudden reversing of direction. Do not reverse direction while the load is still moving.

Make sure that no part of the crane, boom, or load makes contact with any obstruction or comes within a minimum of ten feet from any electrical line.

## TRANSIT

While in transit, the crane must be stowed, preferably in a boom rest. The crane must be prevented from rotating and the hook prevented from swinging.



## INSPECTION AND MAINTENANCE

OSHA and ANSI require frequent and periodic inspections. Records of these inspections must be kept readily available. Liftmoore requires periodic maintenance to ensure proper operation and prolonged life of the crane.

### INSPECTION

#### DAILY INSPECTION

OSHA 29CFR 1910.180 (d)(2)(i) requires the following be checked daily prior to use:

- All control mechanisms for maladjustment interfering with proper operation as well as for excessive wear of components and contamination by lubricants or other foreign matter.
- All safety devices for malfunction. This should include the anti-two block and pressure switch.
- Deterioration or leakage in air or hydraulic systems.
- Crane hooks with deformations or cracks. For hooks with cracks or having more than 15 percent in excess of normal throat opening or more than 10 deg. twist from the plane of the unbent hook.
- Electrical apparatus for malfunctioning, signs of excessive deterioration, dirt, and moisture accumulation. This should include the battery terminals, master disconnect switch, electrical swivel
- The wire rope shall be replaced if any of the following conditions are noted:
  - Kinking, crushing, bird-caging, or other damage
  - Reductions from nominal diameter of more than one-sixty-fourth inch for diameters up to and including five-sixteenths inch, one-thirty-second inch for diameters three-eighths inch to and including one-half inch.
  - Thimble is not in place or is damaged
  - Any evidence of heat damage
  - Six or more randomly distributed broken wires in 1 lay
  - Three or more broken wires in 1 strand in 1 lay

### MONTHLY INSPECTION

A thorough inspection of all ropes in use shall be made at least once a month and a certification record which includes the date of inspection, the signature of the person who performed the inspection and an identifier for the ropes shall be prepared and kept on file where readily available. All inspections shall be performed by an appointed or authorized person. Any deterioration, resulting in appreciable loss of original strength shall be carefully observed and determination made as to whether further use of the rope would constitute a safety hazard. Some of the conditions that could result in an appreciable loss of strength are the following:

- Reduction of rope diameter below nominal diameter due to loss of core support, internal or external corrosion, or wear of outside wires.
- A number of broken outside wires and the degree of distribution of concentration of such broken wires.



- Worn outside wires.
- Corroded or broken wires at end connections.
- Corroded, cracked, bent, worn, or improperly applied end connections.
- Severe kinking, crushing, cutting, or unstranding.

#### PERIODIC INSPECTION

An Annual Inspection Form is included in this manual. OSHA 29CFR 1910.180 (d)(2)ii) requires periodic inspections of this crane. Liftmoore recommends an annual inspection using the included form.

#### MAINTENANCE PRECAUTIONS

The crane should be maintained monthly for safety reasons and to reduce stress on the crane.

#### WARNING!

Never perform any maintenance while the crane has any type of load on it. Use the manual operation procedure to lower the load if necessary.

#### WARNING!

Hydraulic cylinders may have high pressure stored in them even after hydraulic power is removed.

The counterbalance and pilot operated check valve in the cylinder will always hold some pressure in the cylinder. Slightly extending the cylinder then retracting a small amount will relieve most of the pressure in the cylinder. **DO NOT DEADHEAD THE CYLINDER!** This will store the maximum amount of pressure in the cylinder. Care should be taken when either valve is removed from the cylinder as some pressure will still remain.

After any maintenance has been performed the crane shall not be operated until all guards have been reinstalled, all safety

devices reactivated, and maintenance equipment removed.

**LUBRICATION** Refer to the crane specification section for the periodic maintenance schedule and type of lubrication required.

**BOLTS** Bolts may loosen over time due to vibration; therefore they should be checked periodically. If bolts need to be replaced, make sure they are replaced with bolts of equal or greater strength. Check the periodic maintenance schedule (Crane Specification Section) for bolt specification and torque.

#### NOTE!

Sheave and boom and cylinder pivot bolts are not standard bolts. The shank and thread length of these bolts have been modified so that they do not pivot on the threads. Consult the parts section of this manual for part numbers of these bolts.

#### OTHER MAINTENANCE

Refer to parts drawings for any specific maintenance or adjustment procedures such as hydraulic winch brake, rotation drive gear set adjustment, Ect.



### MONTHLY INSPECTION REPORT

Crane Model No. \_\_\_\_\_ Serial Number \_\_\_\_\_



- Are Boom Hitch Pins and Keepers in place? Yes \_\_\_\_\_ No \_\_\_\_\_
- Wire Line Hook with Safety Latch Working? Yes \_\_\_\_\_ No \_\_\_\_\_
- Is Hook OK, (Not bent)? Yes \_\_\_\_\_ No \_\_\_\_\_
- Is Thimble on Wire Rope OK? Yes \_\_\_\_\_ No \_\_\_\_\_
- Is Traveling Block in use? Yes \_\_\_\_\_ No \_\_\_\_\_
- Is Wire Rope OK, not kinked or frayed? Yes \_\_\_\_\_ No \_\_\_\_\_
- Are all Boom Sections straight? Yes \_\_\_\_\_ No \_\_\_\_\_
- Are Sheave Bolts in place and tight? Yes \_\_\_\_\_ No \_\_\_\_\_
- Do all Sheaves rotate easily? Yes \_\_\_\_\_ No \_\_\_\_\_
- Are Mounting Bolts tight? Yes \_\_\_\_\_ No \_\_\_\_\_
- Is Anti Two-Block functioning properly? Yes \_\_\_\_\_ No \_\_\_\_\_
- Is Boom Angle Indicator in place and functioning and is Chart legible? Yes \_\_\_\_\_ No \_\_\_\_\_
- Are Cylinder Mounting Bolts secure? Yes \_\_\_\_\_ No \_\_\_\_\_
- Are Winch Mounting Bolts tight? Yes \_\_\_\_\_ No \_\_\_\_\_
- When stopped does winch drift less than 1.0 Inches? Yes \_\_\_\_\_ No \_\_\_\_\_
- Is Load Chart in place and easily read? Yes \_\_\_\_\_ No \_\_\_\_\_
- Are functions on Pendant operating correctly? Yes \_\_\_\_\_ No \_\_\_\_\_
- Is Hydraulic Reservoir full? Yes \_\_\_\_\_ No \_\_\_\_\_
- Is Outrigger straight and functioning? Yes \_\_\_\_\_ No \_\_\_\_\_

Any items checked 'No' must be repaired before using this crane.





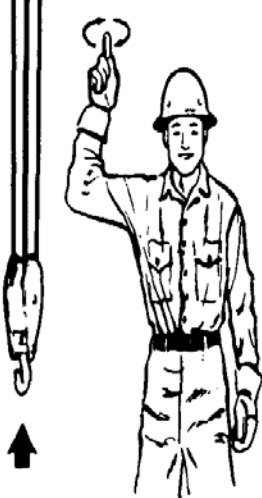
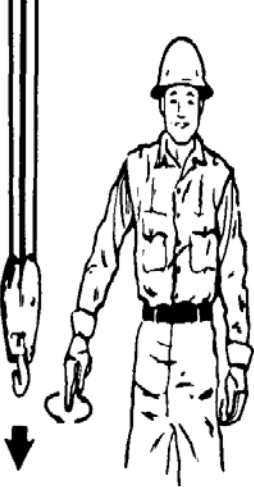

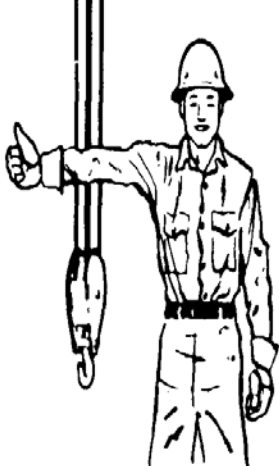
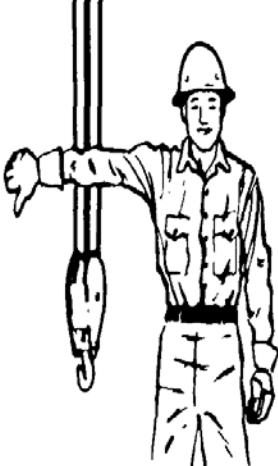

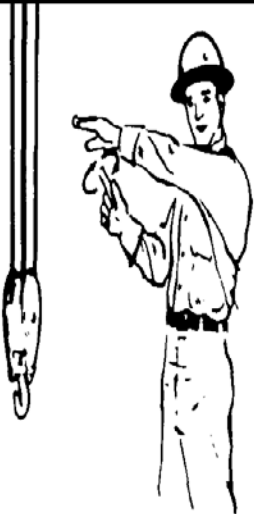
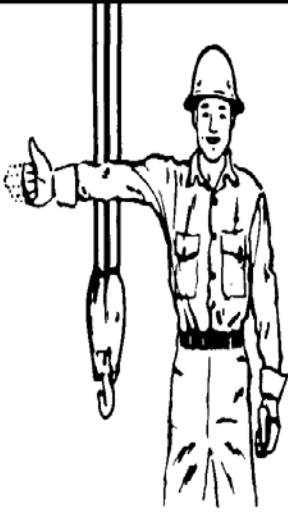
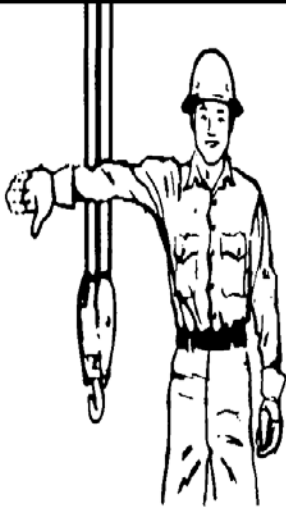
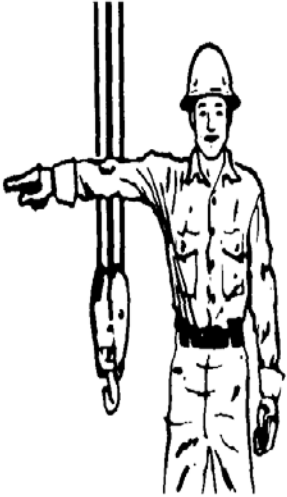
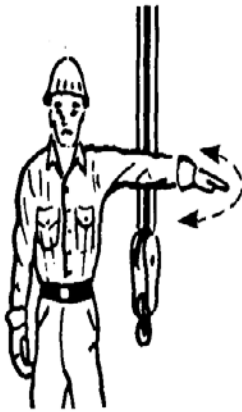
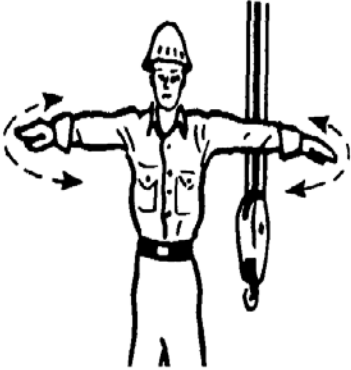

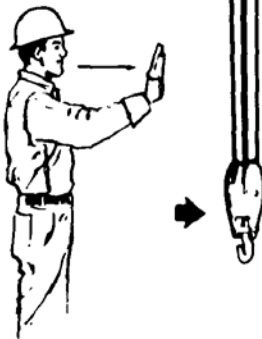

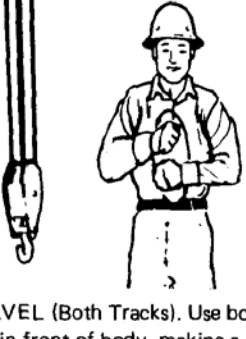
**STANDARD HAND SIGNALS FOR CONTROLLING CRANE OPERATIONS**

 <p><b>HOIST.</b> With forearm vertical, forefinger pointing up, move hand in small horizontal circle.</p>	 <p><b>LOWER.</b> With arm extended downward, forefinger pointing down, move hand in small horizontal circle.</p>	 <p><b>USE MAIN HOIST.</b> Tap fist on head; then use regular signals.</p>
 <p><b>USE WHIPLINE (Auxiliary Hoist).</b> Tap elbow with one hand; then use regular signals.</p>	 <p><b>RAISE BOOM.</b> Arm extended, fingers closed, thumb pointing upward.</p>	 <p><b>LOWER BOOM.</b> Arm extended, fingers closed, thumb pointing downward.</p>

 <p data-bbox="256 751 597 934"><b>MOVE SLOWLY.</b> Use one hand to give any motion signal and place other hand motionless in front of hand giving the motion signal. (Hoist slowly shown as example.)</p>	 <p data-bbox="630 751 963 898"><b>RAISE THE BOOM AND LOWER THE LOAD.</b> With arm extended, thumb pointing up, flex fingers in and out as long as load movement is desired.</p>	 <p data-bbox="1003 751 1336 934"><b>LOWER THE BOOM AND RAISE THE LOAD.</b> With arm extended, thumb pointing down, flex fingers in and out as long as load movement is desired.</p>
 <p data-bbox="267 1497 597 1570"><b>SWING.</b> Arm extended, point with finger in direction of swing of boom.</p>	 <p data-bbox="638 1497 954 1602"><b>STOP.</b> Arm extended, palm down, move arm back and forth horizontally.</p>	 <p data-bbox="995 1497 1328 1602"><b>EMERGENCY STOP.</b> Both arms extended, palms down, move arms back and forth horizontally.</p>

 <p><b>TRAVEL.</b> Arm extended forward, hand open and slightly raised, make pushing motion in direction of travel.</p>	 <p><b>DOG EVERYTHING.</b> Clasp hands in front of body.</p>	 <p><b>TRAVEL (Both Tracks).</b> Use both fists in front of body, making a circular motion about each other, indicating direction of travel, forward or backward. (For land cranes only.)</p>
 <p><b>TRAVEL. (One Track)</b> Lock the track on side indicated by raised fist. Travel opposite track in direction indicated by circular motion of other fist, rotated vertically in front of body. (For land cranes only.)</p>	 <p><b>EXTEND BOOM (Telescoping Booms).</b> Both fists in front of body with thumbs pointing outward.</p>	 <p><b>RETRACT BOOM (Telescoping Booms).</b> Both fists in front of body with thumbs pointing toward each other.</p>
 <p><b>EXTEND BOOM (Telescoping Boom).</b> One Hand Signal. One fist in front of chest with thumb tapping chest.</p>		 <p><b>RETRACT BOOM (Telescoping Boom).</b> One Hand Signal. One fist in front of chest, thumb pointing outward and heel of fist tapping chest.</p>

THIS PAGE INTENTIONALLY LEFT BLANK



F1122-B  
05/12/08

HOUSTON, TEXAS  
FAX: (800) 824-5559 (USA & Canada)  
FAX: (713) 688-6324  
PHONE: (713) 688-5533  
[www.liftmoore.com](http://www.liftmoore.com)



# **GUIDER**

RADIO/CAN REMOTE CONTROL SYSTEM

## **INSTALLATION AND OPERATION MANUAL**

LIFTMOORE  
3B2781CJ.doc  
July 16, 2019  
BK

# GUIDER REMOTE

## INDEX

<b>DESCRIPTION</b> .....	<b>3</b>
<b>OPERATION</b> .....	<b>4</b>
<b>INDICATOR LEDs</b> .....	<b>6</b>
<b>TRANSMITTER AND RECEIVER SYNCHRONIZATION</b> .....	<b>6</b>
<b>TEACH BY CAN CABLE</b> .....	<b>7</b>
<b>TEACH BY RF</b> .....	<b>7</b>
<b>CLONING</b> .....	<b>7</b>
<b>BATTERY CHARGING</b> .....	<b>8</b>
<b>OUTPUTS</b> .....	<b>9</b>
<b>INPUTS</b> .....	<b>10</b>
<b>INSTALLATION</b> .....	<b>10</b>
<b>BEFORE APPLYING POWER!</b> .....	<b>11</b>
<b>SYSTEM TROUBLESHOOTING USING ON BOARD GATE:</b> .....	<b>12</b>
<b>ACCESSING THE CONTROL PANEL</b> .....	<b>12</b>
<b>DIAGNOSTICS</b> .....	<b>13</b>
<b>CALIBRATION</b> .....	<b>14</b>
<b>HISTOGRAM</b> .....	<b>17</b>
<b>SOFTWARE UPDATE</b> .....	<b>18</b>
<b>GATE CONFIGURATION</b> .....	<b>19</b>
<b>WIRING CRANE RECEIVER</b> .....	<b>21</b>
<b>WIRING ENGINE RECEIVER</b> .....	<b>22</b>
<b>ROUTINE MAINTENANCE</b> .....	<b>24</b>
<b>MAINTENANCE PRECAUTIONS</b> .....	<b>24</b>
<b>TROUBLESHOOTING</b> .....	<b>25</b>
<b>TROUBLESHOOTING CHART</b> .....	<b>26</b>
<b>ERROR CODES CRANE RECEIVER</b> .....	<b>28</b>
<b>TRANSMITTER PICTORIAL</b> .....	<b>32</b>
<b>CRANE RECEIVER PICTORIAL</b> .....	<b>33</b>

## GUIDER REMOTE

<b>TILT, CHASSIS SENSOR PICTORIAL.....</b>	<b>35</b>
<b>ROTATIONAL, BOOM SENSOR PICTORIAL.....</b>	<b>36</b>
<b>SPECIFICATIONS.....</b>	<b>37</b>
<b>INSTRUCTION TO THE USER.....</b>	<b>38</b>

## GUIDER REMOTE

### DESCRIPTION

The GUIDER REMOTE is a state of the art microprocessor based Radio Frequency (RF) control system. It will provide the operator the ability to wirelessly operate equipment. The operator is required to follow all OSHA [www.osha.gov](http://www.osha.gov) and other applicable safety standards when operating the equipment. Do not use high power radio devices in close proximity of this product.

The remote control system consists of: the radio transmitter, main receiver module, engine receiver module, and associated optional equipment such as wiring harnesses.

The transmitter is equipped with a trigger, twist to release E-stop

switch, and toggle switches for the various functions. It includes a port for wired control via the built-in Controller Area Network (CAN) system<sup>1</sup>. This unit runs on a 3.7V rechargeable Li-Ion battery when in wireless mode. When in wired mode, the transmitter runs with power supplied by the CAN cable. This is useful if the battery power gets too low to operate the transmitter but continued operation is needed. The port is also used to charge the internal battery.

The system's radio receiver has both a proportional output and ON/OFF outputs to accommodate the functions available on the transmitter. All outputs are current-sourcing. It also includes a port for wired

---

<sup>1</sup> The CAN control will only work with the CRANE module. The ENGINE module only works on RF



## GUIDER REMOTE

(CAN) and RS-232 communication for system diagnostics.

### OPERATION

Power must be applied to the receiver module for the system to work.

Releasing the E-STOP will turn on the transmitter. Pressing the E-STOP button will turn off the transmitter. Pressing the E-STOP will turn off all outputs as a safety feature. If the transmitter goes out of range for more than 2 seconds, all the momentary outputs will turn off as a safety feature, the e-stop output will turn off after 10 seconds.

To operate a proportional output, toggle the switch of the desired function and pull the trigger to the level desired.

**\*Please note that if the trigger is pulled before the function is selected, the proportional output will not work as a safety feature.** Release the trigger and begin again in the proper sequence.

Once the Guider transmitter is on, the operating screen will be displayed. On the top left corner of the screen is transmitter battery display. Plug in the transmitter as soon as possible after seeing the battery symbol turn red. See BATTERY CHARGING below. The top middle of the screen shows the LINK status with the receiver (CAN, RF, or NO LINK), and the top right of the screen shows the system voltage. Load capacity and any errors (if present) are then shown below this when connected to the CRANE receiver. When connected to

## GUIDER REMOTE

the ENGINE receiver, the display will show RUNNING ENGINE FUNCTIONS.

### CONFIGURATION MENU

To navigate to the configuration menu turn the transmitter and receiver off. Press and hold the HORN button then turn on the transmitter. Keep holding the button for greater than 10 seconds until the menu is shown. There are the following options under the configuration menu: TEACH MODE, CLONE TX, SLEEP TIME, RESET TX, and EXIT. To select an option press the HORN button. To scroll down, use the AUX switch and to scroll up, use the RPM switch. To EXIT the configuration menu and go to the operating screen select EXIT.

### TEACH MODE

Select this option to put the transmitter into teach mode and synchronize the receiver and transmitter. See transmitter and receiver synchronization below for more information.

### SLEEP TIME

To save battery life, the transmitter will turn off after 60 minutes no buttons are pressed. The user must press and release the E-STOP at this point to restore transmitter operation. To change the sleep time, select this option and use the RPM and AUX switch to change the number of minutes the transmitter waits to go to sleep. Press the HORN button to save the selected sleep time and exit.

## GUIDER REMOTE

### RESET TX

**Warning! If the transmitter is reset, the receiver will have to be re-synchronized to the transmitter for operation!** To reset the transmitter select RESET TX then press any button.

### CLONE TX

**Warning! This feature can pose a safety hazard for operators if both transmitters are used simultaneously!** Use with caution! Occasionally, it is desirable to have more than one transmitter work with a single receiver. This is accomplished by a process called cloning. See CLONING below for more information.

### INDICATOR LEDs

The receiver module can identify problems with the system in the form of an error code (red LED will be blinking). Check the decal on the receiver to diagnose system problems. Then, refer to the ERROR CODE CHART in this manual for explanation of the error codes. The green LED indicator will blink on the receiver during active operation. It will turn on solid when the Gate is connected to Wi-Fi.

### TRANSMITTER AND RECEIVER SYNCHRONIZATION

Each radio remote system is designed to operate with a unique radio ID code and RF channel sequence. Each receiver is programmed to respond *only* to the transmitter with the correct ID code/RF channel

## GUIDER REMOTE

sequence for which it is set. This feature allows multiple systems to work in close proximity to one another without interference.

In the event that a transmitter becomes damaged and a new one is needed, the receiver can be reprogrammed to respond to the new transmitter. To teach the ID code to the receiver, use the following procedure. **\*Please note that if this procedure is interrupted before it has completed, the system may have intermittent operation:**

For 3B2783A, Crane Receiver:

### TEACH BY CAN CABLE

1. Plug the CAN cable into the CAN port on both the receiver and transmitter and operate a function on the transmitter until the LEDs on the front panel go from steady to flashing for at least 5 seconds. The

units will be synchronized at this point

### TEACH BY RF

1. Turn the transmitter and both receivers off
2. On the transmitter, go to the configuration menu above then select TEACH MODE
3. Apply power to the receiver (engine or crane). The transmitter will display SUCCESFUL and go to operating screen
4. Teach complete

## CLONING

**Warning! This feature can pose a safety hazard for operators if both transmitters are used simultaneously! Use with caution!** Occasionally, it is desirable to have more than one

## GUIDER REMOTE

transmitter work with a single receiver. This is accomplished by a process called cloning. Cloning allows an additional transmitter (B) to have the same ID code as the original transmitter (A). If this feature is desired, use the following procedure:

1. Make sure transmitters and receivers are off
5. On transmitter A, go to the configuration menu above then select TEACH MODE
6. On transmitter B, go to the configuration menu above then select CLONE TX
2. Wait for a few seconds until the screen displays SUCCESFUL
3. Turn off both transmitters
4. Synchronize one of the transmitters to the receivers

If cloning feature has been

invoked and is no longer desired, the ID code of one of the transmitters needs to be changed. This will unclone the transmitters. If this is desired, use the following procedure:

1. Make sure the receiver and transmitters are OFF
2. On the transmitter, go to the configuration menu above then select RESET TX
3. Press any switch again to select a new ID
4. Uncloning complete
5. Use transmitter and receiver synchronization procedure above to link the uncloned transmitter to new receivers

## BATTERY CHARGING

The transmitter is designed with a smart battery charger. The battery can be charged by

## GUIDER REMOTE

connecting the CAN cable from the receiver module (powered on) to the port on the transmitter, or by plugging the AC wall charger or DC cigarette charger (minimum 2A @ 12.6VDC) into the port. Red and green LED indicators on the underside of the transmitter indicate the status of the charger: A red LED indicates that the battery is charging and a green LED indicates that the battery is fully charged.

### *IMPORTANT BATTERY INFO*

When the battery is new, the run-time of the transmitter will be shorter until it has gone through the drain/charge cycle several times. After this point, the unit's current drain should allow at least 20 hours of run-time before a recharge is needed.

The temperature that the transmitter battery is exposed to affects performance and useful life. It is strongly recommended you keep within the following limits:

- A. Charging: -4 to +86°F
- B. Operating: -20 to +122°F
- C. Storing: -4 to +86°F  
(lower is better)

## OUTPUTS

Each of the outputs from the receiver module is designed with built-in short circuit and overload protection. The outputs can also detect a no-load or broken wire condition. These error conditions are evident by the alphanumeric display on the receiver module *or* the HISTOGRAM page on the optional Gate.

## GUIDER REMOTE

The ON/OFF outputs will indicate an error under no load or broken wire status if NOT activated, and will detect a short IF activated. The proportional outputs will detect a no-load or short condition WHEN activated.

### INPUTS

Digital inputs are available for ATB, BOOM LIMIT, and PRESSURE signals. They will function up to battery voltage levels. One analog input is available for a PRESSURE TRANSDUCER. This expects a signal from 4-20mA.

### INSTALLATION

Refer to the WIRING CHART in this manual for hookup of the harness.

To install the receiver module, use the two mounting holes

provided on the enclosure to attach it in a vertical manner with the connectors facing down. Please take extra caution not to damage internal components while installing. For high vibration applications, use shock absorbing mounts. It is advised to mount the unit as high as possible, keeping clear of metal obstructions around the antenna which might affect RF performance. Antenna extension cables are available from to aid in this, if needed.

During operation, the crane receiver will generate heat that must be dissipated. The published amps rating can only be fully achieved if adequate cooling is provided. Mount the controller so that the enclosure makes contact with a metallic surface (chassis, cabinet) to conduct the heat and nothing

## GUIDER REMOTE

protrudes through the potting material to damage internal electronic components.

The main power to the receiver should be connected through a switched, fused line capable of a minimum of 20 amps for Engine receiver and 250 amps for Crane receiver. For best results, connect power (+) to the receiver via an auxiliary terminal of the ignition switch, PTO switch, or ignition relay. Be sure that the ground (-) is connected securely to the chassis or battery with a star washer which digs into the base metal to insure good contact.

All connections must be properly insulated to protect against shorts.

Seal all connections with a non-conductive silicone grease to

prevent corrosion.

### **BEFORE APPLYING POWER!**

- Check power and ground for proper polarity.
- Check the wiring harness for possible shorts before connecting to output devices (i.e., valves and relays) by checking each mating pin terminal.
- Verify that the transmitter battery is fully charged.
- Read the rest of this manual.



## GUIDER REMOTE

### SYSTEM TROUBLESHOOTING USING ON BOARD GATE:

The GATE creates a Wi-Fi access point which allows you to connect to any device with Wi-Fi and web browser such as smart phones, pads or personal computers. It supports Google Chrome, Internet Explorer, Firefox and IOS Safari and allows user to configure, diagnose and troubleshoot the system.

#### ACCESSING THE CONTROL PANEL

1. Turn on the power to the receiver.
2. Use your device and look for the available WiFi networks. A network under the name of "LIFTMOOREXXXXXXXXXX" should be available at

this point, the "XXXXXXXXXX" should be the 10 digit numeric serial # on the crane WIFI receiver. Connect to the network, if required password is 3B2783C1.

3. Once the connection is established, open a web browser on your device. The Chrome browser is recommended.
4. Enter the address `http://192.168.1.1` in the address bar

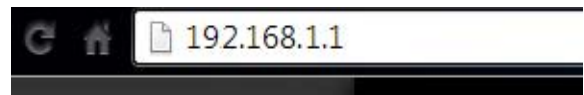

*Address Bar*

5. If the Gate is not used for 5 minutes after power up it will automatically turn off. Recycle power to the receiver to turn it back on.
6. The following options are available from the main screen.

# GUIDER REMOTE

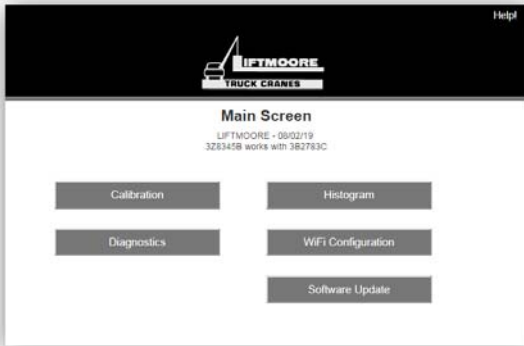

*Main Screen*

## DIAGNOSTICS

Tap the Diagnostic button to see the diagnostic screens, which shows the present state of remote communications, and system I/O.

When the round circle next to a label is dark, the corresponding ON/OFF input or output is sensed to be active or ON.

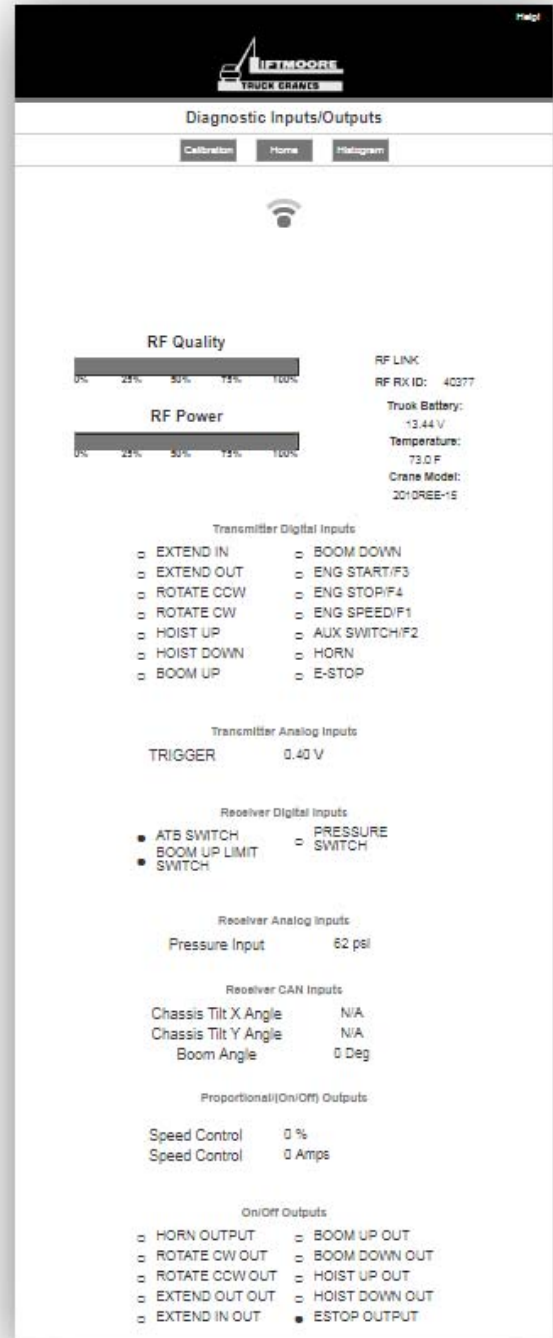

*Diagnostics*

# GUIDER REMOTE

## CALIBRATION

To change the configuration of the unit, tap the Calibration icon.

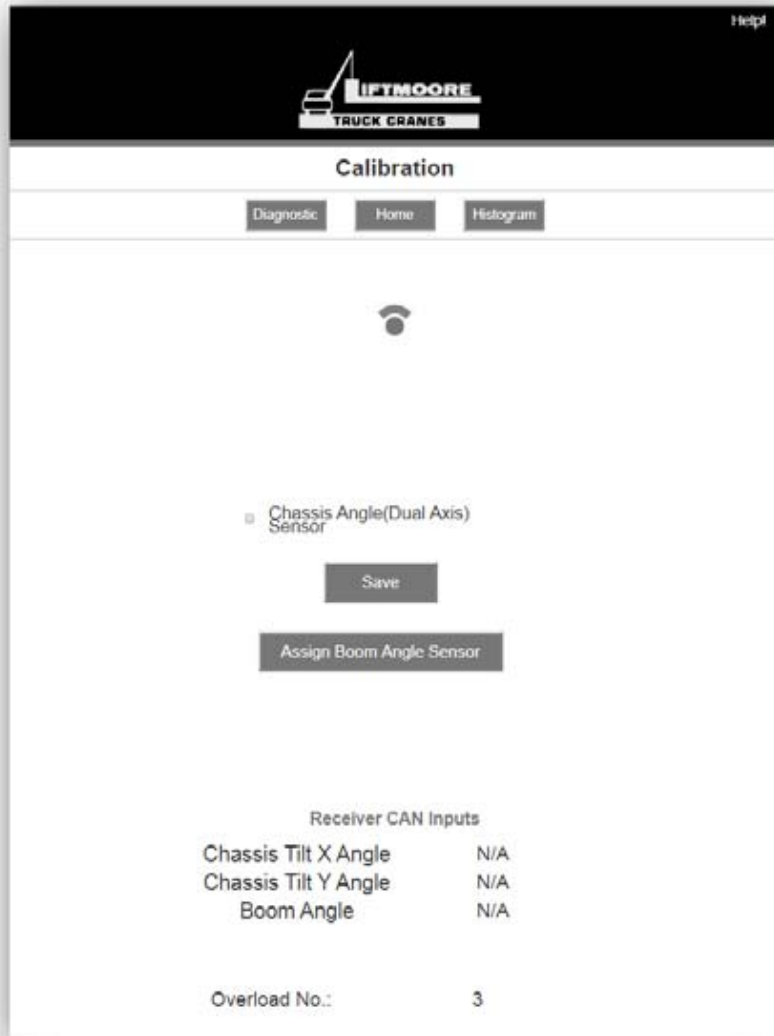

*End user Calibration Page  
Password = 1713*

**THIS DRAWING INTENTIONALLY LEFT BLANK**

FOR FUTURE ADDITIONS

OR

A PART OR FEATURE IS NOT APPLICABLE TO THIS CRANE

**THIS DRAWING INTENTIONALLY LEFT BLANK**

FOR FUTURE ADDITIONS

OR

A PART OR FEATURE IS NOT APPLICABLE TO THIS CRANE

## GUIDER REMOTE

### HISTOGRAM

Tap the Histogram icon to see a set of screens that show which error codes are active and how many times the specific error code has been active.

This feature can be used to troubleshoot machine wiring and other problems. Tapping the Reset button resets the error code counts. The password to reset error codes is (*Contact Liftmoore Inc.*). Tap the Home button to return to the main menu.

Note: the GATE is not a

# GUIDER REMOTE

precision measurement instrument. There may be delays.

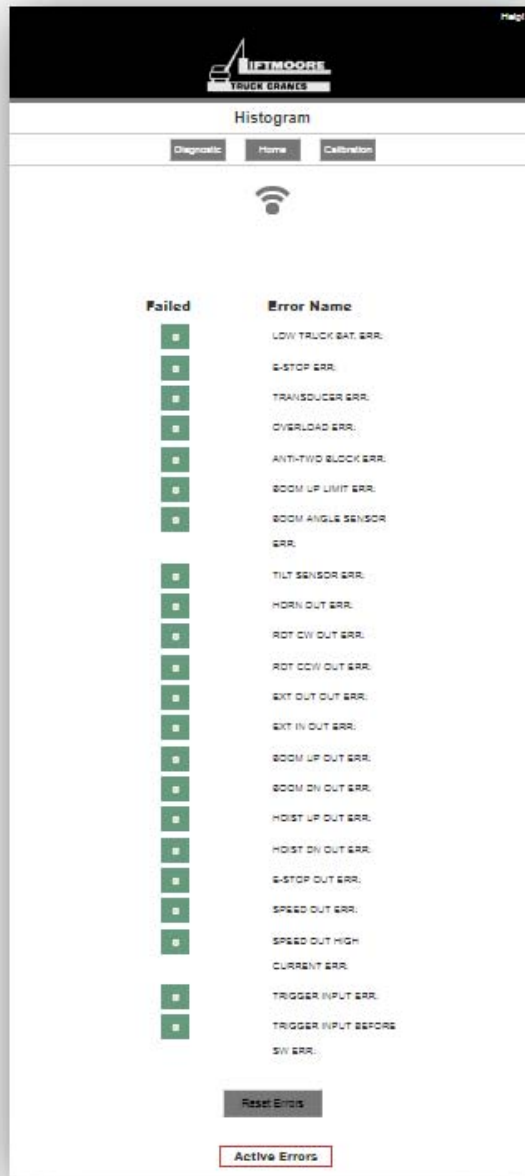

*Histogram Page*

## GUIDER REMOTE

Note: the GATE is not a precision measurement instrument. There may be some delays.

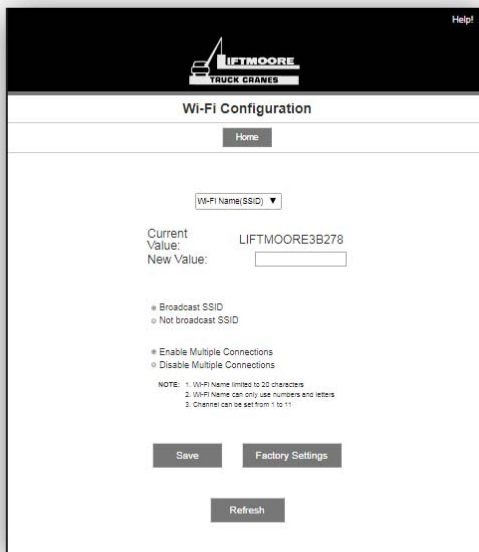

*Gate Configuration Page*

### GATE CONFIGURATION

The password to gain access to the gate configuration page is (*Contact Liftmoore Inc.*).

This page allows you to change the name (SSID) of the Wi-Fi network you are connecting to. Factory settings will rename the Wi-Fi to its original name.

If Broadcast SSID option is selected, the Wi-Fi name (SSID) is public and it will be visible to any other Wi-Fi devices. Otherwise, the Wi-Fi name (SSID) is hidden and it would require manual connection to the network.

If Enable Multiple Connections is selected, multiple connections up to 4 devices could be connected to the GATE. However, only one of



## **GUIDER REMOTE**

the connected devices can use the GATE. If Single connection is enabled, only one device can be connected to the GATE.

NOTE: A reconnect to the new Wi-Fi connection is needed after each change. It is advised to keep a note of the Wi-Fi name in case if Not Broadcast SSID option is selected. Forgetting the Wi-Fi name after selecting this option will require the GATE to be sent to KAR-TECH for RESET.

## GUIDER REMOTE

### WIRING CRANE RECEIVER

#### P1 - DEUTSCH DTM13-12PA

PIN	DESCRIPTION
1	ROTATION CW OUTPUT
2	ROTATION CCW OUTPUT
3	EXTEND OUT OUTPUT
4	EXTEND IN OUTPUT
5	BOOM UP OUTPUT
6	BOOM DOWN OUTPUT
7	HOIST UP OUTPUT
8	HOIST DOWN OUTPUT
9	N/C
10	E-STOP OUTPUT
11	N/C
12	BOOM UP LIMIT SWITCH INPUT

#### P2 - DEUTSCH DT04-4P

PIN	DESCRIPTION
1	POWER (9-30V)
2	BOOM PRESSURE 4-20mA INPUT
3	ATB INPUT
4	HORN OUTPUT

#### P3 - DEUTSCH DT04-4S

PIN	DESCRIPTION
1	POWER (9-30V)
2	GROUND
3	CAN HIGH
4	CAN LOW

#### P4 - DEUTSCH DT04-4S

PIN	DESCRIPTION
1	POWER (9-30V)
2	GROUND
3	CAN HIGH
4	CAN LOW

## GUIDER REMOTE

CON, RECEPTACLE, PLASTIC, CAN

PIN	DESCRIPTION
A	POWER (9-30V)
B	GROUND
C	CAN HIGH
D	CAN LOW
E	SHIELD

**NOTE: MAKE SURE BOTH RED 6GA POWER WIRES ARE CONNECTED TO 9-30V AND 6A BLACK WIRE IS CONNECTED TO GROUND FOR PROPER OPERATION. MAKE SURE ALSO THAT 6GA WHITE WIRES ARE CONNECTED TO THE PUMP.**

## WIRING ENGINE RECEIVER

DEUTSCH DTM13-12PA

PIN	DESCRIPTION
1	GROUND
2	N/C
3	N/C
4	N/C
5	ENGINE SPEED SELECT DIGITAL INPUT
6	N/C
7	N/C
8	AUXILIARY OUTPUT
9	ENGINE START OUTPUT
10	ENGINE STOP OUTPUT
11	ENGINE SPEED OUTPUT
12	POWER (9-30V)

## TRANSMITTER PORT

- A POWER
- B GROUND
- C CAN HIGH
- D CAN LOW
- E NO CONNECTION

## GUIDER REMOTE

### WIRING TILT AND ROTATIONAL SENSOR

<b>DT04-4P-E008 CON/ KT PN: 055-157-0402</b>	
<b>PIN</b>	<b>DESCRIPTION</b>
1	POWER 9-30V
2	GROUND
3	CAN HIGH
4	CAN LOW

## GUIDER REMOTE

### ROUTINE MAINTENANCE

Clean transmitter regularly with a damp cloth and mild detergent.

Inspect electrical wiring for wear points or other damage. Repair as required.

Inspect all connections for looseness or corrosion. Tighten and/or "seal" as necessary.

Guider pendants that include a trigger control should be cleaned periodically by blowing air around the trigger area to remove any debris that would prevent proper operation. Apply a light machine oil to the point of rotation when clean.

### MAINTENANCE PRECAUTIONS

When performing any inspection

or maintenance work on the remote system, always exercise care to prevent injury to yourself and others or damage to the equipment. The following are general precautions, which should be closely followed in carrying out any maintenance work.

Do not have hydraulic power available to the valves when performing electrical tests.

Never operate or test any function if any person is in an area where they could be hurt by being hit or squeezed by the hydraulic equipment.

Turn power off before connecting or disconnecting valve coils or other electrical loads.

### **TROUBLESHOOTING**

This next section provides basic operator level troubleshooting for the GUIDER REMOTE system. If, after following these instructions, the system still does not function, contact your sales representative for further instructions or servicing.

## GUIDER REMOTE

### TROUBLESHOOTING CHART

<b><i>PROBLEM</i></b>	<b><i>SOLUTION</i></b>
No functions work	<ol style="list-style-type: none"><li>1. Verify transmitter power source – battery, CAN cable, external supply, etc</li><li>2. Verify that receiver control module power source is present at its input connector</li><li>3. Check for proper system ground</li><li>4. Check the receiver or control module LED status display for functionality or errors</li><li>3. Check the hydraulic system</li><li>4. Check to see if the crane receiver has sufficient cooling.</li></ol>
Certain functions do not work	<ol style="list-style-type: none"><li>1. Check the wiring and connections from the receiver control module to the control module to the valve coil for the particular function that does not work</li><li>2. Check the receiver control module LED status display for possible fault or error indication</li><li>3. Check the hydraulic system</li><li>4. Check the electrical system</li><li>5. Check to see if the crane receiver has sufficient cooling.</li></ol>
Functions operate intermittently	<ol style="list-style-type: none"><li>1. Check for loose connections at the valve coil</li><li>2. Check the receiver control module LED status display for functionality or errors</li><li>3. Check the receiver antenna for damage</li></ol>

## GUIDER REMOTE

	<p>and possible obstructions</p> <ol style="list-style-type: none"><li>1. Check the hydraulic system</li><li>2. Check to see if the crane receiver has sufficient cooling.</li></ol>
--	--



## GUIDER REMOTE

### ERROR CODES CRANE RECEIVER

Number of Red LED Blinks	Error Code	Transmitter Display
1	RF Communication Error	RF signal will show red x
2	Low Truck Battery Error	Truck low batt err
3	E-STOP Condition	E-STOP mode err
4	Transducer Error	Transducer err
5	Overload Condition	Overload err
6	ANTI-TWO-BLOCK Condition	ANTI-TWO-BLOCK
7	BOOM UP LIMIT Condition	Boom limit err
8	Rotational Sensor Error	Boom angle sens err
9	Tilt Sensor Error	Tilt sensor err
10	HORN Output Error	Horn err
11	ROTATE CW Output Error	Rotate CW err
12	ROTATE CCW Output Error	Rotate CCW err
13	EXTEND OUT Output Error	Extend out err
14	EXTEND IN Output Error	Extend in err
15	BOOM UP Output Error	Boom up err
16	BOOM DOWN Output Error	Boom down err
17	HOIST UP Output Error	Hoist up err
18	HOIST DOWN Output Error	Hoist down err
19	E-STOP Output Error	E-STOP out err
20	SPEED Output Error	Speed out err
21	SPEED Output High Current Error	Overcurrent err
22	TRIGGER Input Error	Trigger err
23	TRIGGER before Switch Error	Trigger start err
N/A	N/A	Chassis tilted

#### **Error code explanations:**

- 1** Transmitter is off  
 Transmitter went to sleep mode  
 Interference in RF communication link
- 2** System voltage is below 11V (12V system)

## GUIDER REMOTE

- 3 E-STOP button is pressed on the transmitter
- 4 No voltage present at pressure input or voltage is out of specified range (4-20mA)
- 5 Overload condition based on Gate setting is present
- 6 Anti-Two Block condition present, ATB input is low
- 7 Boom Limit input active, BOOM LIMIT input is low
- 8 No CAN messages are being received from Tilt sensor. Check wiring
- 9 No CAN messages are being received from Rotational sensor. Check wiring
- 10-20 Short or open load/coil on output
- 21 Current at SPEED output is above rated current, output will turn off
- 22 No voltage present on trigger in transmitter
- 23 Trigger was pulled on transmitter before switch was activated

**Chassis tilted - If the chassis is tilted over five degrees, all functions are reduced to slow speed. The following outputs will also be disabled: Boom Down, Hoist Up, and Extend Out.**

## GUIDER REMOTE

### ERROR CODES ENGINE RECEIVER

EC	POSSIBLE CAUSE
1	RF COMMUNICATION ERROR
2	ENGINE SPEED OUTPUT ERROR

#### **Error code explanations:**

- 1** Transmitter is off  
Transmitter went to sleep mode  
Interference in RF communication link
- 2** Short or open load/coil on output

## GUIDER REMOTE

### PARTS LIST

<i>PART NUMBER</i>	<i>DESCRIPTION</i>
<b>3B2782B</b>	RADIO TRANSMITTER
<b>3B2783C</b>	CRANE RADIO RECEIVER
<b>3B2784A</b>	ENGINE RADIO RECEIVER
<b>020-506-0250</b>	CAN ADAPTOR CABLE 25'
<b>B20032B</b>	CHARGER, 12 VDC CIGARETTE LIGHTER PLUG
<b>B20072A</b>	FAST CHARGER SUPPLY, 110V AC WALL
<b>A3003EA</b>	TILT SENSOR
<b>A3003FA</b>	ROTATIONAL SENSOR

There are no user-serviceable parts inside the transmitter or the receiver. Return the units for service.

Note: For operation with negative ground systems only.

#### **WARNING:**

The GUIDER REMOTE must be operated in compliance with all applicable safety regulations, rules, and practices. Failure to follow required safety practices may result in death or serious injury.

The information, specifications, and illustrations in this manual are those in effect at the time of printing. We reserve the right to change specifications or design at any time without notice.

# GUIDER REMOTE

## TRANSMITTER PICTORIAL

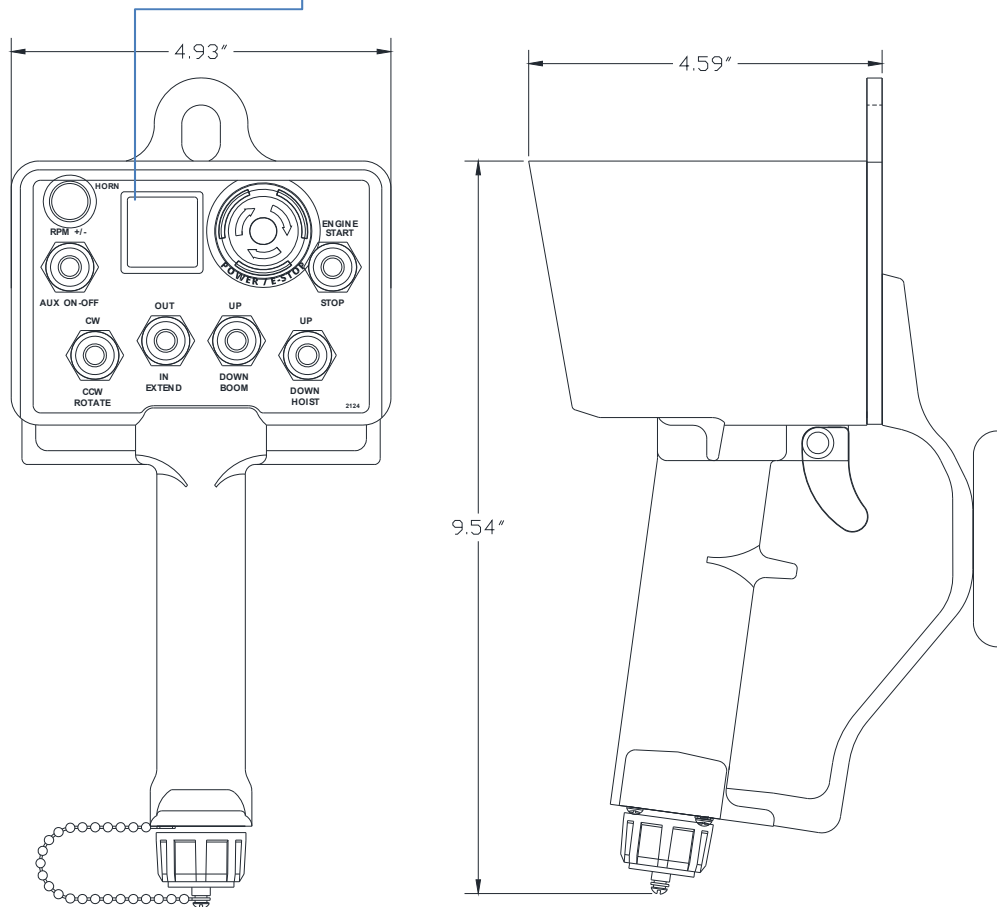
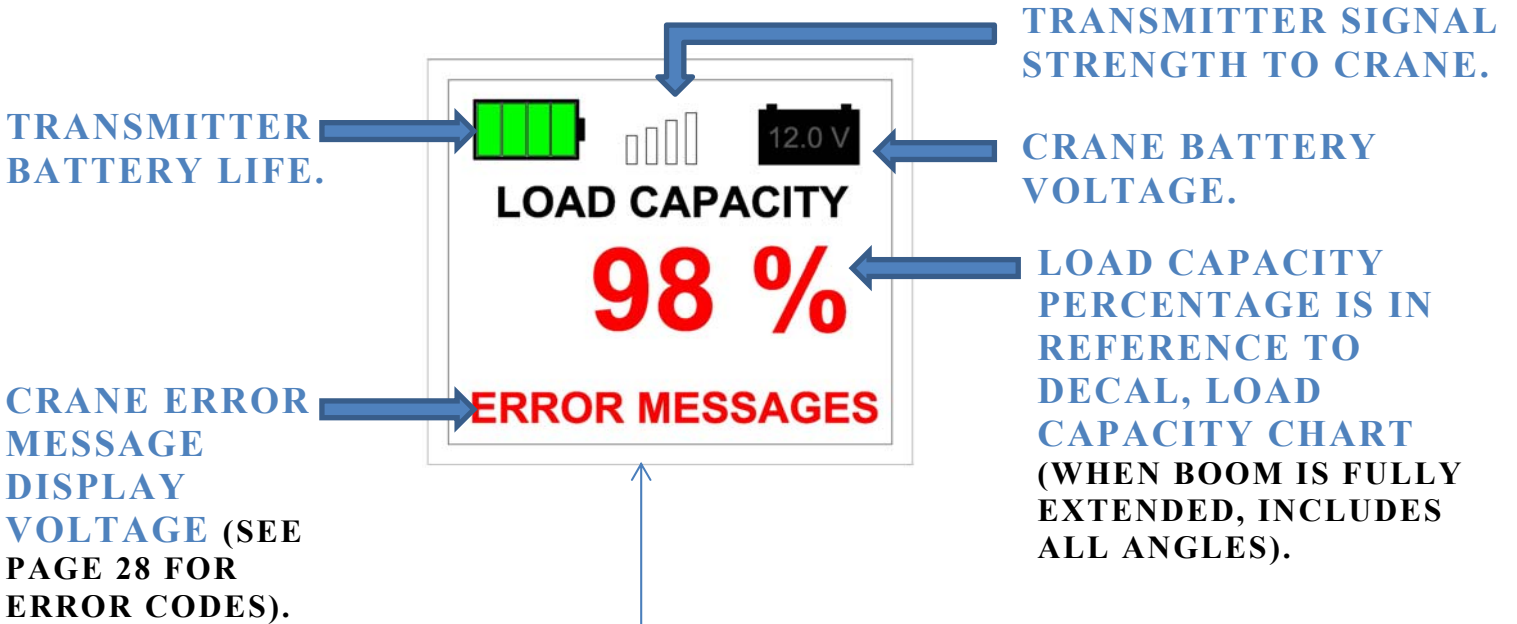

# GUIDER REMOTE CRANE RECEIVER PICTORIAL

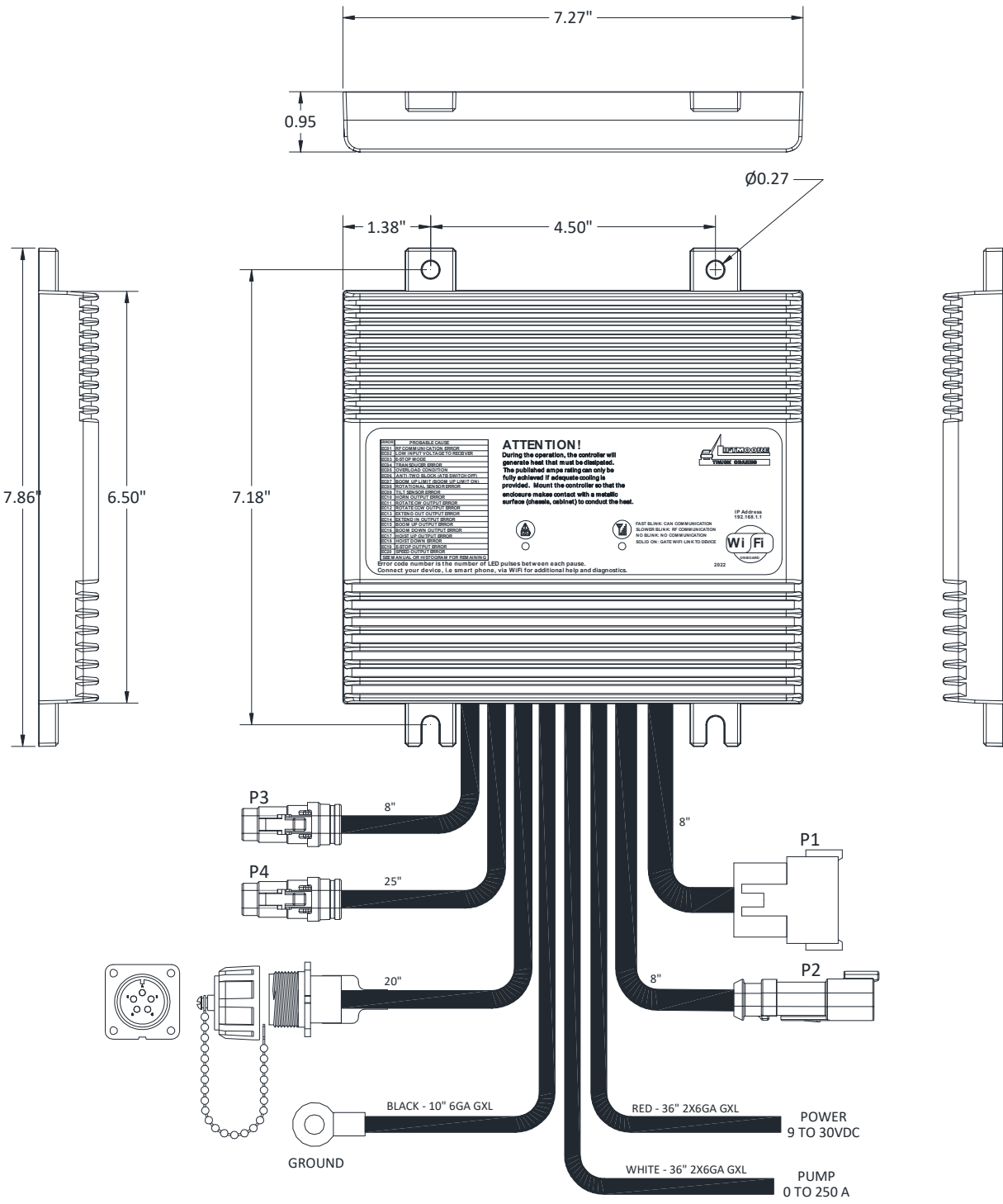

# GUIDER REMOTE

## ENGINE RECEIVER PICTORIAL

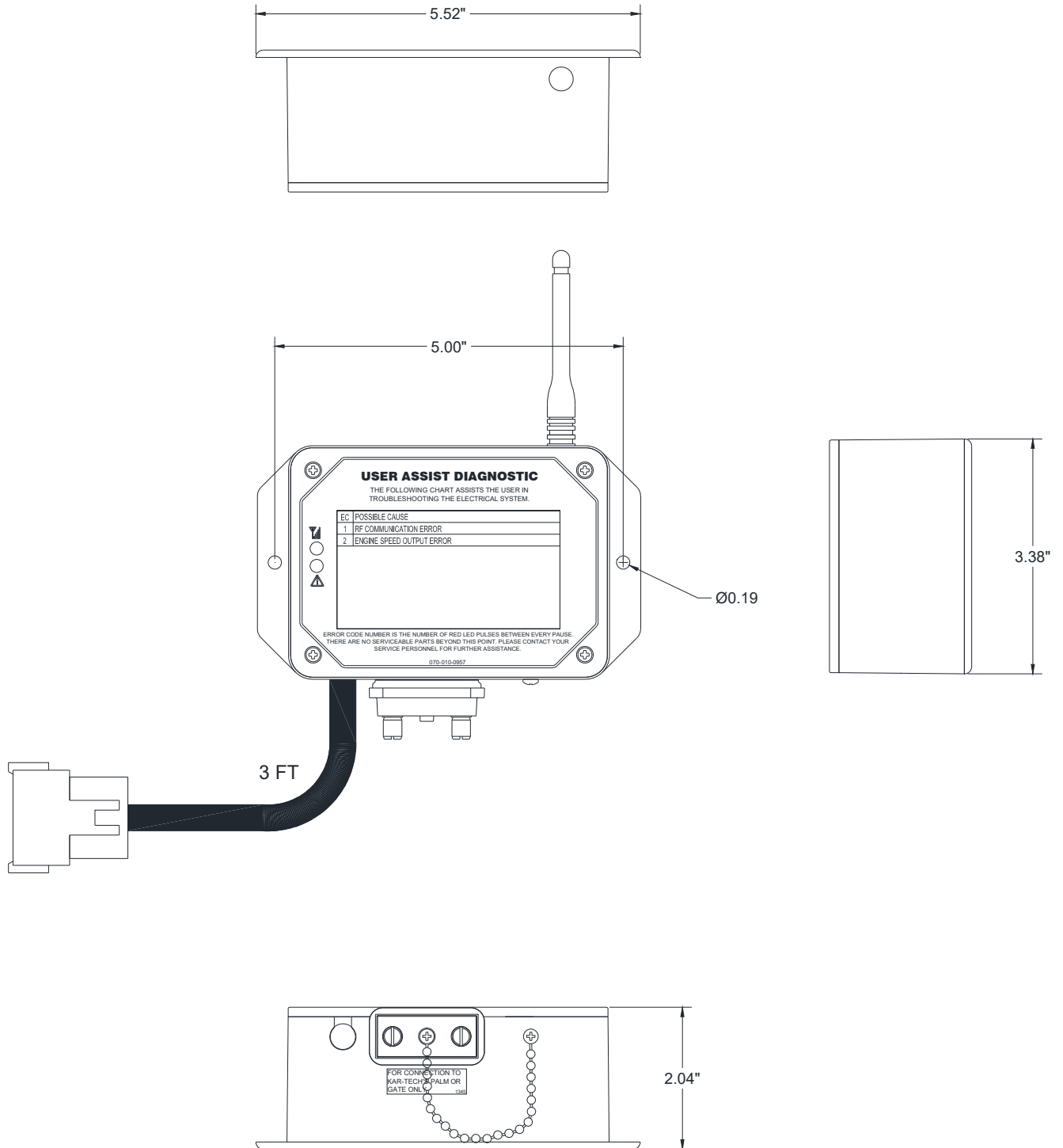

# GUIDER REMOTE

## TILT, CHASSIS SENSOR PICTORIAL

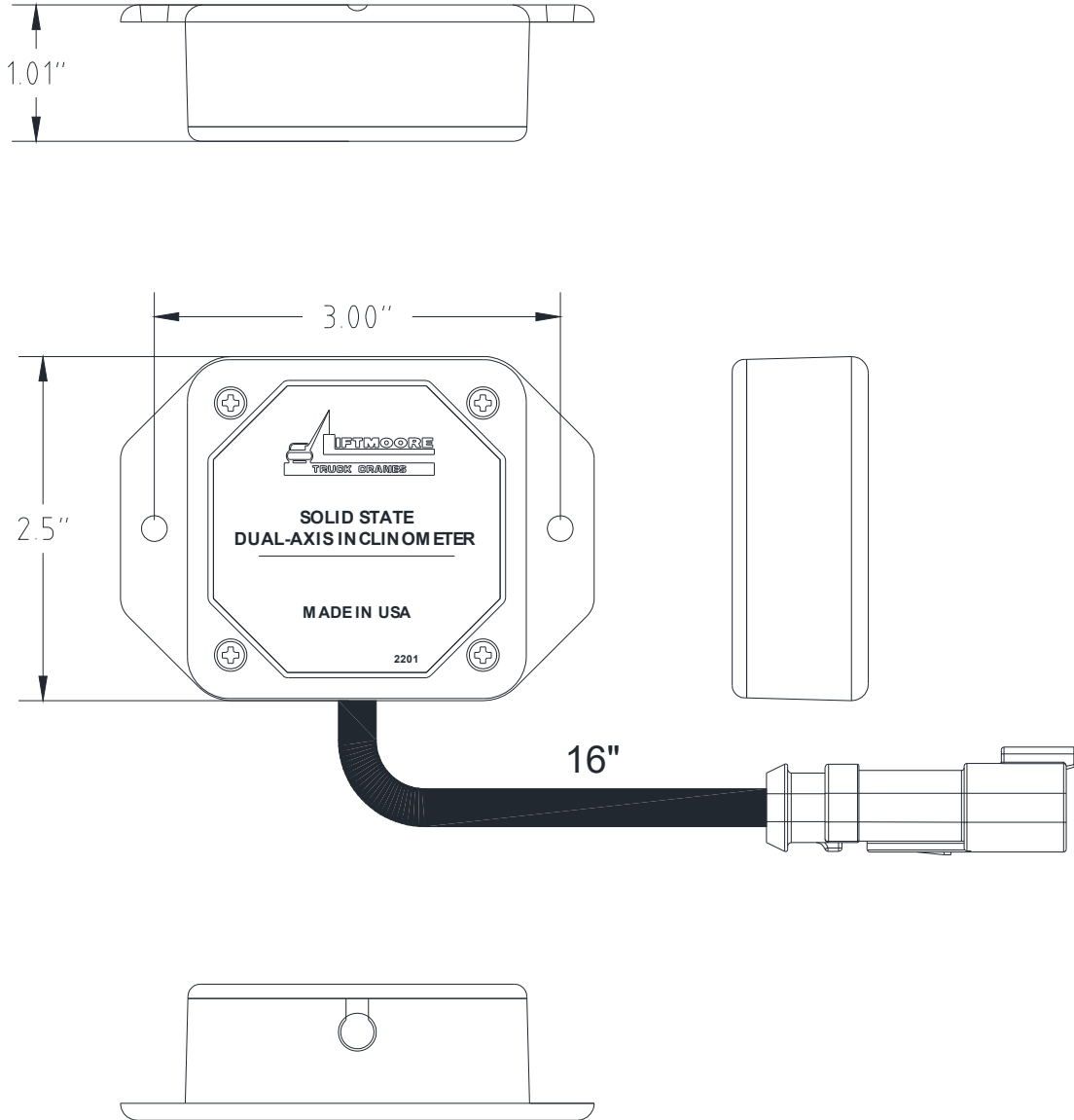



# GUIDER REMOTE

## ROTATIONAL, BOOM SENSOR PICTORIAL

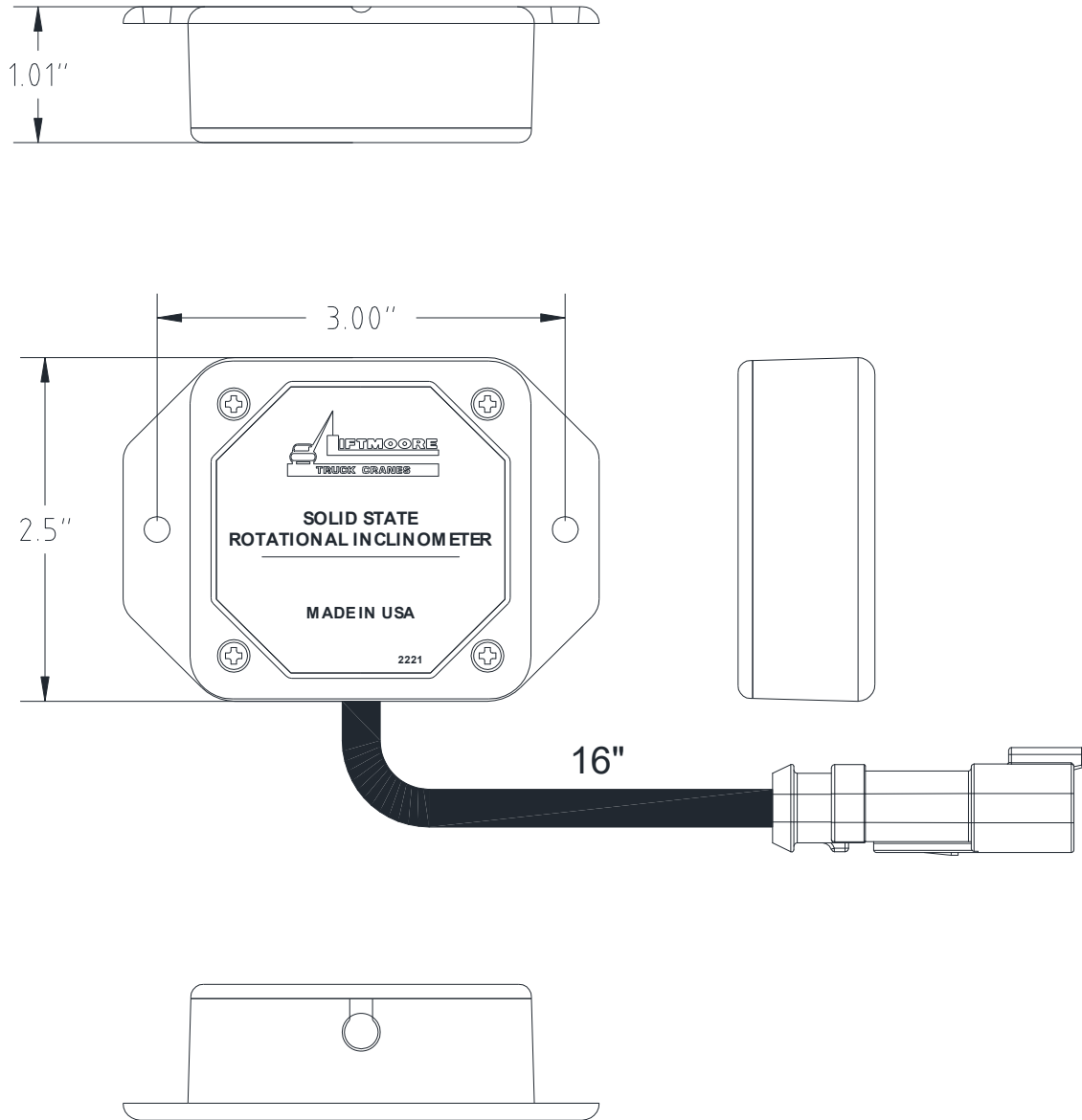

## GUIDER REMOTE

### SPECIFICATIONS

**FCC ID:** P4U-MOD164

Industry Canada Certification Number: 4534A-MOD164

EQUIPMENT CLASS: PART 15 SPREAD SPECTRUM TRANSMITTER

#### **TRANSMITTER**

Power supply .....	3.7V Li-Ion Rechargeable Battery
Fast charger temperature range .....	+5 °C to +60 °C
Operating temperature - Radio .....	-40 °C to +85 °C
Storage temperature .....	-40 °C to +100 °C
RF Frequency .....	902-928 MHz
RF Transmit power (EIRP) .....	100 mW
LCD display operating range (if equipped) .....	-20 °C to +70 °C
Vibration .....	3G to 200Hz
Shock .....	50G
NEMA .....	12

#### **RECEIVER**

Power supply voltage .....	9-30VDC
Operating temperature .....	-40 °C to +85 °C
Storage temperature .....	-40 °C to +100 °C
Outputs .....	5.0A max each, sourcing
Pump Output .....	250A max, sourcing
Digital Inputs (when equipped) .....	supply voltage
Analog Inputs (when equipped) .....	0-5VDC/4-20mA
RF Frequency .....	902-928 MHz
Vibration .....	3G to 200Hz
Shock .....	100G
NEMA .....	4X

## GUIDER REMOTE

### INSTRUCTION TO THE USER

This equipment has been tested and found to comply with the limits for a class B digital device, pursuant to part 15 of the FCC Rules. These limits are designed to provide reasonable protection against harmful interference in a residential installation. This equipment generates radio frequency energy and if not installed and used in accordance with the instructions, may cause harmful interference to radio communications. However, there is no guarantee that interference will not occur in a particular installation. If this equipment does cause harmful interference to radio or television reception, which can be determined by turning the equipment off and on, the user is encouraged to try to correct the interference by one or more of the following measures:

- \* Reorient or relocate the receiving antenna.
- \* Increase the separation between the equipment and receiver.
- \* Connect the equipment into an outlet on a circuit different from that to which the receiver is connected.
- \* Consult the dealer or an experienced radio/TV technician for help.

This equipment has been certified to comply with the limits for a class B computing device, pursuant to FCC Rules. In order to maintain compliance with FCC regulations, shielded cables must be used with this equipment. Operation with non-approved equipment or unshielded cables is likely to result in interference to radio and TV reception. The user is cautioned that changes and modifications made to the equipment without the approval of manufacturer could void the user's authority to operate this equipment.

THIS PAGE INTENTIONALLY LEFT BLANK



HOUSTON, TEXAS  
FAX: (800) 824-5559 (USA & Canada)  
FAX: (713) 688-6324  
PHONE: (713) 688-5533  
[www.liftmoore.com](http://www.liftmoore.com)

## SAFETY SYSTEM

The safety system is designed to help prevent damage to the crane that would be caused by overload or two-blocking. The system consists of a load sensor, anti-two block device (optional on smaller, electric cranes), and limiting system control board.

When the applicable switch detects an overload or two-block condition, the limiting system will prevent activation of winch up, boom down, and extend out since these directions would cause damage. Winch down, boom up, extend in, and power rotation will still function so that the crane can be moved to a safe configuration.

### CAUTION!

Never de-activate or override safety functions. Doing so can result in serious damage to the crane and possibly injury or death.

### LOAD SENSOR

A pressure activated switch in the elevation cylinder acts as a load sensor. This switch is normally closed and opens at the preset pressure corresponding to the load rating of the crane.

### CAUTION!

The load sensor will not function when the elevation cylinder is fully retracted and is inaccurate when the boom is below horizontal.

### CAUTION!

The operator must never rely strictly on the load sensor to determine overload conditions. The load and load limits must always be known and adhered to.

### ANTI-TWO BLOCK

The anti-two block device (optional on smaller electric cranes), mounted on the boom crown plate, consists of a normally open switch actuated by a lever. A weight is attached to the lever and holds the switch

closed. If the weight is lifted by the hook or travel block the switch opens.

The power and signal wires are wired through the cord reel, which is in turn wired to the ATB switch.

### LIMITING SYSTEM CONTROL

The limiting system control prevents output of winch up, boom down and extend out if it is not receiving a signal from either the ATB or load sensor.

The ATB does not trip boom down when winch is mounted on the boom.

There is a one second delay before deactivation of boom down when the load sensor is tripped to prevent false readings caused by pressure spikes.

## MISCELLANEOUS

### UP LIMIT SWITCH

The up limit switch prevents the elevation cylinder from reaching full extension. If the elevation cylinder were to "dead-head", the resulting pressure would activate the load sensor, preventing boom down. The boom would then have to be lowered using the manual operation buttons on the solenoid valves.

### CIRCUIT BREAKER, FUSE

For electric cranes a 150 Amp circuit breaker is supplied with the crane. It should be installed as close to the battery as possible. For hydraulic cranes a 10 Amp blade type fuse is supplied.

### DISCONNECT SWITCH

A power disconnect switch is supplied with the crane. Power to the crane should be turned off whenever not in use. This is to prevent inadvertent or unauthorized use and will help prevent corrosion at electrical connections.



## ELECTRIC HOIST

Permanent Magnet Motor

This Liftmoore crane features an electrically driven planetary gear hoist. The hoist is powered in both directions and features an automatic internal brake to positively control the load.

The hoist is permanently lubricated at the factory. Barring damage or part replacement, no further lubrication is necessary.

### MOTOR

The hoist motor is a permanent magnet, reversible, direct current (DC) motor.

#### CAUTION!

The hoist motor is rated for intermittent duty. Duty cycle is limited to 5 minutes in 30 to allow the motor to cool. Extended use can damage the motor.

#### CAUTION!

When the motor approaches stall, a very rapid heat build up occurs which can cause permanent motor damage. Discontinue use when the motor speed is reduced excessively by voltage drop or load.

### BRAKE

The hoist features a single acting, overrunning brake. It automatically activates to hold the load and assist in lowering the load.

#### WARNING!

The hoist brake only functions in one direction. If the hoisting direction is reversed by reversing the rope winding direction the brake will not hold and the load will fall. Serious injury or death could occur.

The brake is factory set and is not adjustable. If the brake fails to hold the load or if downward drift becomes excessive the brake must be replaced.

### DIRECTIONAL CONTROL

Motor direction is controlled by either a solenoid pack or sealed contactor. Schematically, they are identical - two double pole-double throw solenoids are used to reverse polarity to the motor terminals.

Signal voltage, controlled by the pendant, energizes the selected directional solenoid, directing power to the winch terminal through the normally open terminal. The other terminal remains grounded through the normally closed terminal of the other solenoid.

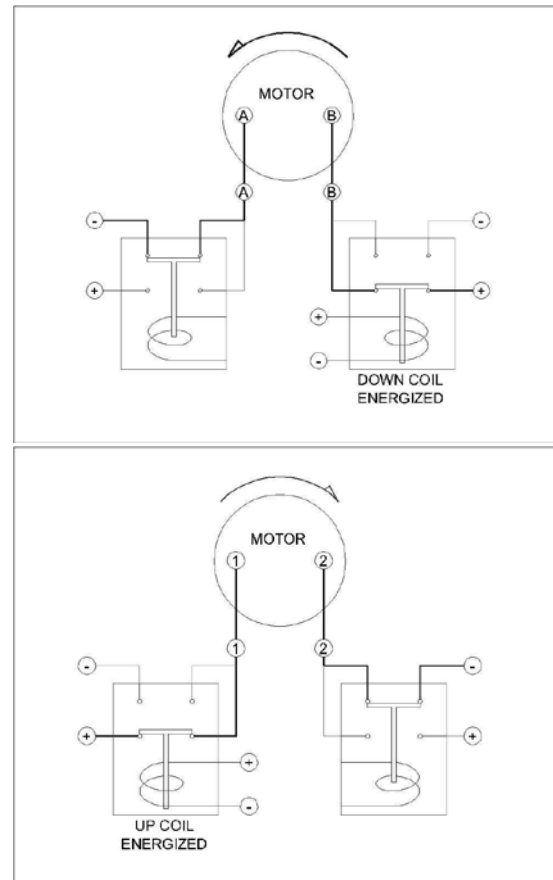

## HYDRAULIC SYSTEM FOR ELECTRIC CRANES

The hydraulic system consists of the hydraulic pump, manifold, solenoid valves, cylinders, motors, and tubing and hoses. Hydraulic power is generated by the electrically driven hydraulic pump on the outside of the housing. The hydraulic system is plumbed in series so that more than one function can be operated simultaneously.

### PUMP

The hydraulic pump assembly consists of a DC permanent magnet electric motor, pump, and reservoir.

The motor is activated by the pump solenoid. The solenoid is energized by the pendant control whenever a hydraulic function is activated.

The pump provides fluid pressure to power hydraulic functions. The system incorporates an adjustable relief valve to prevent damage that can be caused by over pressurizing the system.

Fluid is drawn from and returned to the reservoir. Servicing the hydraulic pump consist of maintaining the oil level. The reservoir should be kept as full as possible to prevent condensation from forming inside the tank. Also ensure the oil is not contaminated by water, dirt, rust, etc. See crane specification sheet for hydraulic oil type.

### SOLENOID VALVES

Each hydraulically operated function is controlled by a 4-way, 3-position (open and close) center solenoid valve. It is electrically operated and spring biased to center. A manual operation button is incorporated in the coil-retaining nut. Valves are mounted to the series manifold.

## CYLINDERS

Most hydraulic cylinders are double acting cylinders with integrally mounted counterbalance valve and pilot operated check valves. Refer to the cylinder drawings for specific information.

All cylinders use a counter-balance load holding cartridge valve on the extend port.

This valve performs 3 functions:

- Controls the rate of decent when lowering the load
- Keeps load from falling in the event of sudden loss of system pressure, such as when a hose bursts.
- Acts as a relief valve to prevent damage from induced load or thermal expansion.

It allows free flow to extend then blocks flow until opened by pilot pressure to the retract port or when the relief pressure is reached.

Some cylinders utilize a pilot operated check valve on the retract port to prevent the cylinder from creeping out under no load conditions. This valve allows flow into, but prevents flow from the retract port, thus hydraulically locking the cylinder until opened by pilot pressure to the extend port.

## MOTORS

### THE HYDRAULIC MOTOR USED BY THE ROTATION DRIVE IS A HIGH-TORQUE, LOW-SPEED CONSTANT DISPLACEMENT MOTOR. MANUAL OPERATION

If electrical problems occur the solenoid valves may be operated manually by depressing the manual operation button incorporated in the coil-retaining nut. Using a blunt object such as a bolt or screwdriver handle may be required to assist operation if high pressures are needed. Refer to the manifold drawing for function valves and directions.

If possible, activate the pump by activating a hydraulic function on the pendant. If this does not work, then energize the pump solenoid using a jumper from the hot side of



the solenoid to the coil post where the WHT/BLK wire is connected. If this fails also then battery voltage can be applied directly to the pump motor.

If hydraulic power is lost while a load is suspended, the load can be lowered by decreasing the setting on the counter-balance valve. This should only be done in extreme cases. The valve must be reset before the crane is returned to use.

**WARNING!**

The boom may fall if the adjustment is made too fast. Do not stand where the boom may hit you if it falls. Serious injury or death may result

**WARNING!**

The area between the boom and the cylinder, the boom and the housing, and the cylinder and the housing will change as the boom position changes and could form pinch points. Do not position any part of your body in these areas as it may be pinched or crushed as the boom lowers.

To decrease the setting, loosen the locknut on the valve, then slowly turn the adjustment stem **CLOCKWISE** until the load begins to lower. Count the number of turns so that the valve can be returned to its original setting.

Alternately, a pressure gage must be put on the retract port to adjust the setting so that approx. 1800 PSI is required to lower the boom with no load.

Test the setting by lifting a known load near the moment rating.



## TROUBLESHOOTING SAFETY SYSTEM

DTCH Relay Card

To check functions controlled by the safety system check the status indicators. (See Relay Box Assembly drawing.) If only one of the safety functions is not working, activate that function and check for error codes and/or its output status indicator.

For non-FM systems, if the status indicator lights then the problem is in the wiring or in the solenoid coil. If the light does not illuminate, check the control pendant. If the control pendant is good then the crane control module needs to be replaced.

For FM systems, check for error codes. If none are present, see the FM Troubleshooting section.

If boom out, boom down and winch up are not working, confirm that the control board has power. Confirm that the board is receiving a signal from the ATB and load sensor.

If the error code is active, ensure that the crane is not overloaded and that the ATB lever is holding the switch closed. Check for voltage at the ATB and Load Sensor inputs.

### CHECK LOAD SENSOR SWITCH

If the load sensor input is not receiving voltage, locate the load sensor connector inside the crane housing. The plug side will have a red wire and a gray wire, the receptacle side will have a red and a white wire.

Disconnect and check for continuity between the two pins on the receptacle (switch side). If there is no continuity then the load sensor is bad and needs to be replaced.

### CHECK ATB SWITCH

If the ATB input is not receiving voltage remove the ATB housing cover and disconnect the connector. Check for continuity on the switch side. Lifting the weight should break the continuity. If either of these conditions is incorrect the switch is bad and needs to be replaced.

### CHECK CORD REEL

Check the ATB switch if not done so already. Locate the ATB connector inside the crane housing. The plug side will have a red wire and a black wire. The receptacle side will have a white wire and a black wire.

Disconnect the plug going to the switch. Check for continuity between the two pins on the receptacle. Have someone lift the weight on the ATB and continuity should be broken. If either of these conditions are incorrect then the cord reel is bad and needs to be replaced.

### CHECK POWER TO SAFETY SWITCHES

If the safety switch is good, check for voltage at pin 1 (the red wire) on the plug. If there is no voltage, follow the wire back to the 6-pin power distribution plug, checking for breaks or shorts.

Remove the power distribution receptacle (cap).

#### **NOTE!**

Removing the cap will disconnect power to all electrical components. Be sure to replace the cap before continuing.

Check the cap for bent pins. Check that all wires are fully seated in the plug. If they are not, then remove the green locking wedge and push the wires forward until seated. Reinstall the wedge ensuring that no wires are pushed back.



## TROUBLESHOOTING ELECTRIC HOIST

Permanent Magnet, Contactor Controlled

### IMPORTANT NOTE!

The importance of first physically checking every connection between the battery and the crane cannot be overstressed!

Poor connections or poor grounding account for a large percentage of hoist problems. Time is often wasted chasing other probable causes only to eventually find a loose or corroded connection. **Measuring the voltage is not sufficient.** Often a poor connection will allow enough amperage to operate a meter or test light, but not enough to operate the hoist, which requires very high amperage.

If the problem is random and intermittent then it is almost assuredly a loose or bad connection.

Another common problem is low battery voltage. Even if the battery is good when troubleshooting begins, running the winch can quickly drain a battery. If it can be done safely, it is best to have the vehicle running.

Also check the control socket and plug for bent, corroded, or dirty pins.

### CAUTION!

As the motor approaches stall, due to low voltage or excessive load, a very rapid heat build up occurs which will quickly damage the motor. If the motor is not turning, do not operate the switch for more than a second. Allow the motor to cool between attempts to make it run.

## HOIST OPERATES IN ONLY ONE DIRECTION

If the hoist only operates in one direction swap the control wires on the contactor.

Activating the pendant switch in the working direction should now operate the hoist in the previous non-working direction.

**Example:** if hoist up is not working, after swapping the control wires activating the hoist down switch should cause the hoist to go up.

If it does then the hoist and contactor are working correctly and the problem is in the pendant crane socket or wiring. If it does not then the problem is the contactor or brake.

If the motor tries to turn but stalls then the problem is most likely the brake. Also, if the contactor makes a clicking noise then that is a good indication that it is working and, again, the problem is most likely the brake.

If the control wires were swapped in the previous step, return them to their original positions. Swap the motor wires (labeled 1 and 2). It is usually easiest to swap them at the motor.

Activating the pendant switch in the working direction should now operate the hoist in the previous non-working direction.

**Example:** if hoist up is not working, after swapping the motor wires activating the hoist down switch should cause the hoist to go up.

If it does, then one side of the contactor is not working and it needs to be replaced.

If it does not work, the problem is a brake malfunction. Inspect the brake installation. Correct any problems found. The brake cannot be repaired. Replace if any damage is found.



## HOIST DOES NOT RUN IN EITHER DIRECTION

If the hoist does not run in either direction then the problem is either lack of power to the control socket or pendant, lack of sufficient power to the motor, or hoist brake malfunction or motor failure.

If the contactor clicks when the switch is activated then the control socket is getting power.

If all connections have not been checked, do so now. Also ensure that the battery still has sufficient power. As a rule of thumb, if it has enough power to start the engine, then it is good.

Activate the winch toggle switch and check for voltage at motor contacts. If positive voltage is measured at both terminals, the problem may be the ground wire from the contactor. Check for tightness or corrosion on this wire.

Once sufficient power is ensured, if there is any indication that the motor is trying to turn but stalls the problem is the brake – have it replaced.

If there is no indication that the motor is trying to turn and the contactor has been tested, then replace the motor.

## TESTING THE PENDANT AND CONTROL WIRING

If the problem is narrowed to the control wiring, it is most likely caused by a cut or disconnected wire. A visual inspection of the

wiring should be made and repairs made as necessary.

Refer to the schematic and pendant drawing for pin functions and locations.

If no visual defects are found and if a continuity tester is available, disconnect the pendant and check for continuity between the control socket pin and terminal at the contactor.

Alternately, a piece of wire or metal object may be used to short between the control socket power pin and the socket hoist pin(s). If the hoist operates then the problem is in the pendant.

If not, check for power at the control socket power pin. If there is no power, trace the wiring back, checking each connection until the problem is found. Correct as necessary.



## TROUBLESHOOTING HYDRAULIC PUMP

Electric Pump, 14P Socket

### IMPORTANT NOTE!

The importance of first physically checking every connection between the battery and the crane cannot be overstressed!

Poor connections or poor grounding account for a large percentage of electrical problems. Time is often wasted chasing other probable causes only to eventually find a loose or corroded connection. **Measuring the voltage is not sufficient.** Often a poor connection will allow enough amperage to operate a meter or test light, but not enough to operate the motor, which requires very high amperage.

If the problem is random and intermittent then it is almost assuredly a loose or bad connection.

Another common problem is low battery voltage. Even if the battery is good when troubleshooting begins, running the motor can quickly drain a battery. If it can be done safely, it is best to have the vehicle running.

Also check the control socket and plug for bent, corroded, or dirty pins.

### CAUTION!

As the motor approaches stall, due to low voltage or excessive load, a very

rapid heat build up occurs which will quickly damage the motor. If the motor is not turning, do not operate the switch for more than a second. Allow the motor to cool between attempts to make it run.

### FOAMY FLUID

If the fluid foams then the problem is the pump seal – have it replaced.

### PUMP DOES NOT RUN

If both the pump and winch are not working, the problem is power related or control wiring related. Troubleshoot those areas first.

If the solenoid is actuating it will make a clicking noise. If the solenoid is not clicking, check for power at the coil input (small screw terminal) on solenoid when the Boom Up switch is activated. If there is no power then the problem is the electrical wiring harness or pendant control wiring.(refer. to CONTROL TROUBLESHOOTING CHART).

If the coil is getting power when the switch is activated, but not clicking then the problem is most likely the solenoid.

If the solenoid is clicking check for full power input to the solenoid. Trace the wiring back to the crane input, checking for power at each connection until the problem is found. If full electrical power to the motor is confirmed then the motor is faulty and should be replaced.



## DEUTSCH CONNECTIONS & PINS

**P/N 30908**  
PLUG CONTROL 4-PIN



**P/N 30635**  
4 PIN POLLACK

**P/N 18753**  
PLUG 14 PIN DTCH



**P/N 18751**  
SOCKET 14 PIN DEUTSCH

**P/N 19916**  
DTCH 1P PLUG



**P/N 19917**  
DTCH 1P RECPT

**P/N 20322**  
DTCH 5P RECPT PLUG



**P/N 20185**  
DTCH 5P RECPT PLUG  
W/ 25' WIRE



### FEMALE'S



**P/N 19915** CONT. DTCH 20GA  
**P/N 18757** CONT. DTCH 16 GA  
**P/N 19918** CONT. DTCH 12 GA

**P/N 19935**  
SEALING PLUG DTCH 20GA



**P/N 21285**  
BUSS DTCH 12P RECPT 12PB



**P/N 19854**  
WEDGE DEUTSCH 12P PLUG

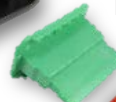

### MALE'S



**P/N 20771** CONT. DTCH 20GA  
**P/N 18756** CONT. DTCH 16 GA  
**P/N 19919** CONT. DTCH 12 GA

**P/N 18758**  
SEALING PLUG DTCH 16GA



**P/N 19853**  
DTCH 12P-B PLUG



**P/N 19846**  
WEDGE, DEUTSCH 2P PLUG

**P/N 19847**  
DTCH 2P PLUG

**P/N 19909**  
WEDGE DTCH DTM  
12P-A PLUG



**P/N 19857**  
DTCH 6P RECPT BUSS



**P/N 19850**  
WEDGE DTCH 6P PLUG



**P/N 19845**  
DTCH 2P RECPT

**P/N 19848**  
WEDGE, DEUTSCH 2P RECPT



**P/N 19908**  
DTCH DTM 12P-B PLUG



**P/N 19907**  
DTCH DTM 12P-A PLUG

**P/N 19849**  
CONNECTOR, DTCH 6P PLUG



**RED RING INSUL**  
**P/N 18770** 22-18GA #10



**BLU RING INSUL**  
**P/N 15802** 14-16GA #8  
**P/N 15736** 14-16GA #10  
**P/N 21478** 14-16GA 0.25  
**P/N 15871** 14-16GA 0.31



**YEL RING INSUL**  
**P/N 16781** 10-12GA #8  
**P/N 16111** 10-12GA 0.25  
**P/N 15771** 10-12GA 0.31  
**P/N 26725** 14-16GA .437



**BRAZED RING**  
**P/N 15837** 4GA 0.31  
**P/N 15563** 6GA 0.25  
**P/N 15148** 6GA 0.31  
**P/N 15737** 1/0GA 0.31



**LUG RING**  
**P/N 16915** #1GA 0.25  
**P/N 17063** #1GA 0.37  
**P/N 16922** #4GA 0.25  
**P/N 17064** #4GA 0.37  
**P/N 16923** #1/0GA 0.25  
**P/N 17062** #1/0GA 0.37



**QUICK SPLICE**  
**P/N 31407** 14-18GA (TAN)  
**P/N 32141** 18-22GA (RED)

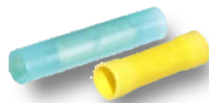

**BUTTED CONN**  
**P/N 15565** 14-16GA (BLU)  
**P/N 16110** 10-12GA (YLV)



**FUSE CONN.**  
**P/N 19921** HOLDER 16GA  
**P/N 18456** 15AMP BLADE

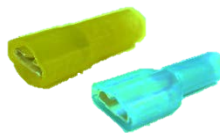

**FEMALE TERM**  
**P/N 15797** 10-12GA (YLV)  
**P/N 15566** 14-16GA (BLU)



**MALE TERM**  
**P/N 15838** 10-12GA (YLV)  
**P/N 32118** 14-16GA (BLU)



F2435-A  
11/27/17  
I:FORMS

HOUSTON, TEXAS  
FAX: (800) 824-5559 (USA & Canada)  
FAX: (713) 688-6324  
PHONE: (713) 688-5533  
www.liftmoore.com

THIS PAGE INTENTIONALLY LEFT BLANK

## SECTION 3 CRANE SPECIFICATIONS

### MODEL 3612REE 7-15 CRANES

MOMENT RATING                    12,000 FT-LBS

MAX SINGLE LINE LOAD        1,800 LBS

MAX DOUBLE LINE LOAD       3,600 LBS

LIFTING CAPACITIES AT VARIOUS LOAD RADII:

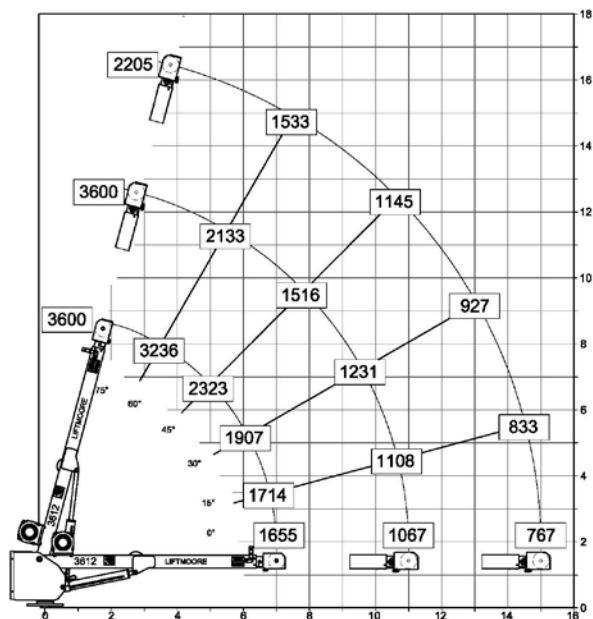

POWERED FUNCTIONS AND EXPECTED TIMES:

WINCH	UP: 12 s	DOWN: 13.5 s	3 REVOLUTIONS
BOOM ELEVATION	UP: 18 s	DOWN: 17 s	
BOOM EXTENSION	OUT: 30 s	IN: 30 s	
ROTATION	90°	13 s	

ELECTRICAL:

VOLTAGE	12 VDC
FUSE	15 AMP
CIRCUIT BREAKER	150 AMP

NOTE: FUNCTION TIMES ARE BASED ON THESE INPUT VALUES



F2612-0  
10/29/19

HOUSTON, TEXAS  
FAX: (800) 824-5559 (USA & Canada)  
FAX: (713) 688-6324  
PHONE: (713) 688-5533  
[www.liftmoore.com](http://www.liftmoore.com)

PERIODIC MAINTENANCE SCHEDULE MODEL 3200 CRANES		
<b>BOLTS</b>		
<b>MOUNTING BOLTS</b>	1/2-13 GRADE 8 TORQUE 110 FT-LBS DRY	EVERY 4 MONTHS
<b>LUBRICATION</b>		
<b>GREASE FITTINGS</b>	SEE DRAWING	EVERY OTHER WEEK
<b>HYDRAULIC FLUID</b>	STANDARD Chevron AW Hydraulic Oil 46 or equivalent SAE 15 weight oil  COLD WEATHER AW 32 or equivalent SAE 10 weight oil	CHECK DAILY, FILL AS NEEDED
<b>BEARINGS</b>	Oil Center Research PM 600 Military grease or equivalent Benton Based Grease NLGI Grade 2	EVERY 6 HOURS OF OPERATION

**ROTATION GEAR SETTING**

See the Rotation Components drawing for adjustment procedure if backlash becomes so great that excessive boom movement occurs. Factory setting is such that the displacement of the retracted boom tip is less than 1 inch.

**WINCH**

The winch is factory lubricated and should not require further lubrication in its lifetime. The winch brake cannot be adjusted. If brake drift is more than 1 inch under full load then it must be replaced.





## CRANE LUBRICATION POINTS

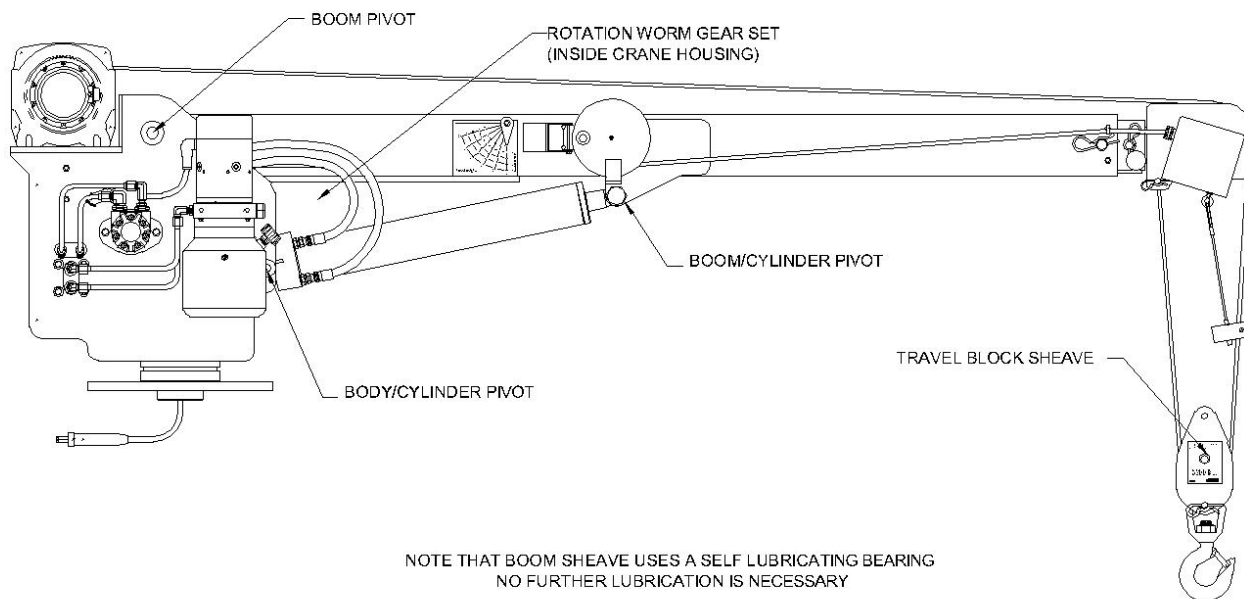

Houston TX  
(713)-688-5533  
www.liftmoore.com

DRWN BY: BLF  
DATE: 3/18/03

CRANE LUBRICATION POINTS 8.1K-16K

DRAWING NO.  
**50460-A**



F2612-0  
10/29/19

HOUSTON, TEXAS  
FAX: (800) 824-5559 (USA & Canada)  
FAX: (713) 688-6324  
PHONE: (713) 688-5533  
www.liftmoore.com

THIS PAGE INTENTIONALLY LEFT BLANK



F2612-0  
10/29/19

HOUSTON, TEXAS  
FAX: (800) 824-5559 (USA & Canada)  
FAX: (713) 688-6324  
PHONE: (713) 688-5533  
[www.liftmoore.com](http://www.liftmoore.com)

## LIST FOR BOX, CRANE PARTS 3612REE WP

Items with \* have detailed DWG's.

P/N 28980 - BOX, CRANE PARTS 3612REE-15 WP  
DTCH, 23872 WINCH, VOLT METER

- 1) P/N 28981 - MANUAL, CRANE 3612REE-15 WP.....1pc
- 2) P/N 25866 - WIRE, BATTERY #1 X 30' W\MECON..... 1pc
- 3) P/N 30815 - SCREW, HHC 0.50-13 X 2.50 GR8.....4pcs
- 4) P/N 30474 - WASHER, LOCK 0.50 GR5 PLATED..... 4pcs
- 5) P/N 31957 - NUT, HEX 0.50-13 GR8 PLATED..... 4pcs
- 6) P/N 16878 - BREAKER, CIRCUIT 150 AMP.....2pcs
- 7) P/N 16915 - TERMINAL, LUG #1 GA 0.25 DIA..... 2pcs
- 8) P/N 30766 - SWITCH, DISCONNECT..... 1pc
- 9) P/N 17010 - BRACKET, SWITCH MNT. ELE. CRN..... 1pc
- 10) P/N 17063 - TERMINAL, LUG #1 GA 0.37 DIA..... 2pcs
- 11) P/N 18600 - PLATE, CRANE-TRUCK STABILITY CHART..... 1pc
- 12) P/N 25007 - DECAL, LOAD CAPACITY 12,000..... 1pc
- 13) P/N 23144 - LEVEL AND TAPE ASSEMBLY ..... 1pc
- 14) P/N 27490 - SWITCH, DISCONNECT COVER PLATE..... 1pc
- 15) P/N 26084 - WIRE, GROUND 1/0 X 3' LONG.....1pc
- 16) P/N 30760 - PIN, HITCH 0.75 X 4.50 W/H-PIN.....1pc



F2599-0  
10/28/19

HOUSTON, TEXAS  
FAX: (800) 824-5559 (USA & Canada)  
FAX: (713) 688-6324  
PHONE: (713) 688-5533  
[www.liftmoore.com](http://www.liftmoore.com)

ITEMS WITH (\*) ARE LOCATED IN BOX PARTS

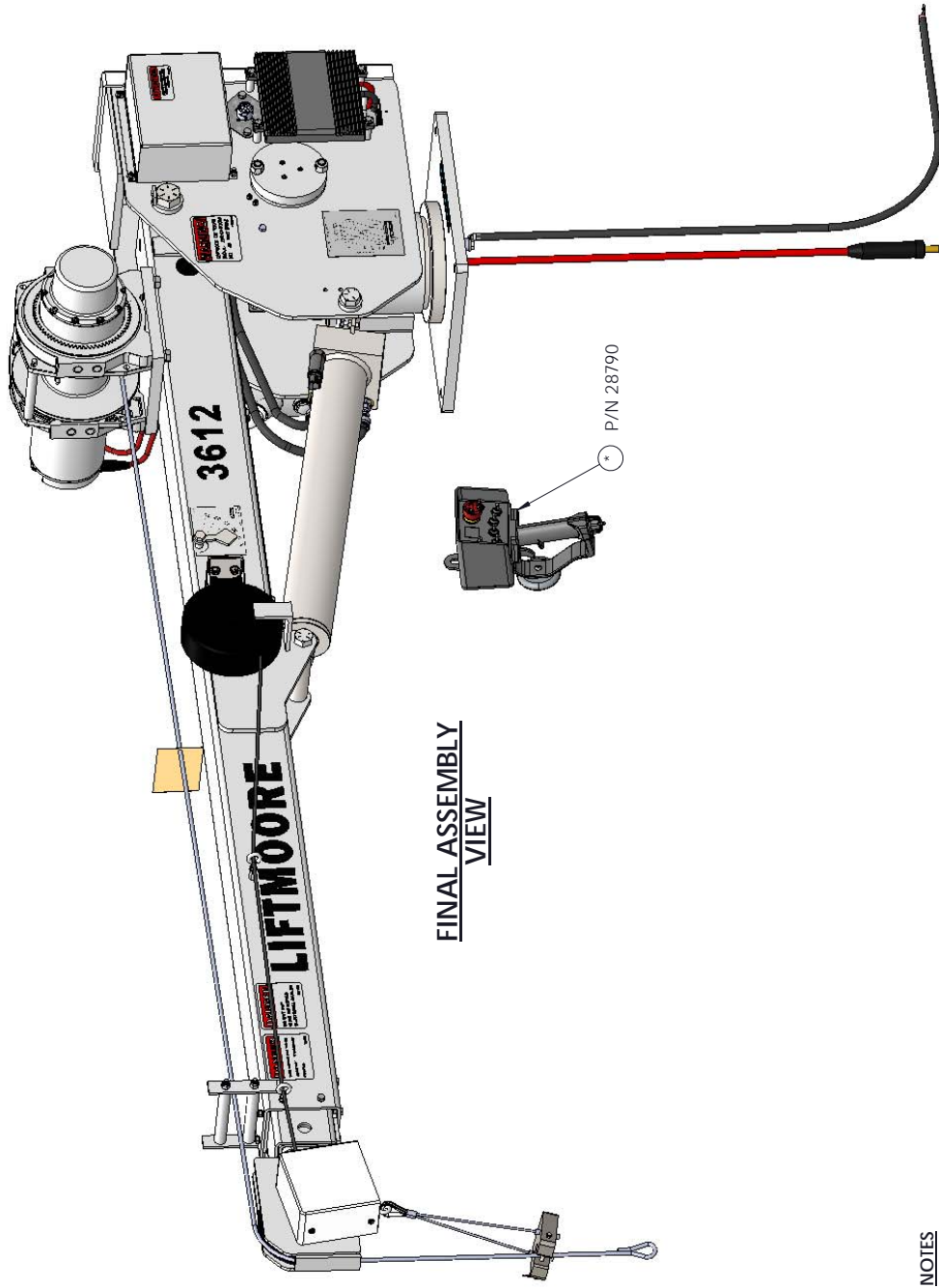

**FINAL ASSEMBLY VIEW**

**NOTES**

- 1 - AFTER ROUTING WIRES, DOUBLE CRIMP TERMINALS WITH CRIMP TOOL ON DIE SETTING 25 THEN ADD ITEM # 53 (0.75" HEAT SHRINK)
- 2 - DOUBLE CRIMP TERMINAL WITH CRIMP TOOL ON DIE SETTING 16 THEN ADD ITEM # 54 (0.50" HEAT SHRINK)
- 3 - RUN CORD REEL WIRE THRU ITEM # 39
- 4 - RUN INCLINOMETER WIRE THRU ITEM # 50
- 5 - APPLY LOC-TITE VC-3 TO THREADS.
- 6 - HAND TIGHT WITH FLAT HEAD SCREW DRIVER.
- 7 - TORQUE TO 5 FT-Lbs.
- 8 - HAND TIGHT WITH 5/32 T-HANDLE

ITEM NO.	PART NUMBER	PART DESCRIPTION	QTY.
1	28579	CRANE ASSY 3612/2010REE-15 1ST	1
2	30889	SCREW, IHC 0.25-20 X 0.50 GR5	3
3	30889	WASHER, LOCK 0.25 GR5 PLATED	3
4	24793	COVER, BACK 3612 PLASTIC	1
5	32689	SCREW, HHWSMS 0.25-20 X 0.75	4
6	28583	COVER, 2010 CONT. & SOLENOIDS	1
7	70022	WEDGE, WIRE ROPE ANCHOR	1
8	28794	TRANSUDICER, PRESSURE 5000 PSI	1
9	15881	DECAL LOGO 7.50" X 4.00"	1
10	15612	DECAL CAUTION PIN MUST BE IN	1
11	15618	DECAL DANGER ELECTRIC INJURY	1
12	15577	DECAL ATTENTION BATTERY	1
13	16102	DECAL CAUTION READ MANUAL	1
14	32685	DECAL LIFTING PERSONNEL	1
15	15579	DECAL DANGER CABLES	1
16	32608	DECAL MOTOR MAGNETS DAMAGE	1
17	25007	DECAL LOAD CAPACITY 12,000	1
18	15615	DECAL WARNING TRAVELING BLOCK	1
19	22375	DECAL ANGLE PENDULUM LEFT	1
20	22376	DECAL ANGLE PENDULUM RIGHT	2
21	33165	DECAL LIFTMOORE - 2.50" HORIZONTAL BACK LETTERING	1
22	16103	DECAL USE 46AW HYD. OIL	1
23	33145	WASHER, FLAT #10 GR2 PLATED	4
24	32639	WASHER, LOCK #10 GR2 PLATED	6
25	24345	PLATE, SERIAL 3612	1
26	18310	DECAL WARNING TAG - DO NOT EXT	1
27	32995	ROPE, WIRE 0.25 X 62' W/TH&LP	1
28	17164	SCREW, SOC HD 10-24 X 0.62 SS	6
29	MH0143	CAP, BREATHER 3/4 NPT/MONARCH	1
30	24960	CLAMP, HOSE SUPPORT 0.25 ID	3
31	28126	SCREW, SOC HD 0.25-20 X 0.25SS	5
32	32957	CLAMP, HOSE SUPPORT 0.62 ID	1
33	28968	PLATE, CONTROL SOCKET CAN/ MC	1
34	24342	DECAL 3612 HORIZONTAL 2.00" FRANKLIN HEAVY FONT	2
35	22908	ATB ASSY, DEUSCH CONNECTOR	1
36	28597	WIRE, BATTERY #4 X 8' W/RM	1
37	30674	BOOT, RUBBER 1 & 1/0	2
38	21520	WASHER, LOCK 0.25 STAR	2
39	28791	CONTROL, RM RECEIVER GUIDER WP	1
40	28916	SPACER, RECEIVER	4
41	31110	WASHER, FLAT 0.25 GR5 PLATED	4
42	31465	SCREW, IHC 0.25-20 X 2.50 GR5	4
43	30833	NUT, HEX NYLOC 0.25-20 GR2	4
44	28034	PLATE, COVER VOLT/AMP SLOT, MC	1
45	28853	INCLINOMETER, BOOM ANGLE CAN	1
46	17882	WASHER, LOCK #8 GR2 PLATED	2
47	28963	SCREW, SOC HD 8-32 X 0.37 SS	2
48	17063	TERMINAL, IUG #1 GA 0.37 DIA	2
49	15563	TERMINAL, RING 6 GA 0.25 DIA	1
50	28936	CLAMP, HOSE SUPPORT 0.38 ID	2
51	22804	PIN, CLEVIS 0.58 X 4.00 PLATED	1
52	31603	CLIP, HAIRPIN 0.50 - 0.62	1
53	28965	TUBE, HEAT SHRINK 0.75 DIA ADH (X 1.50" LG)	2
54	28966	TUBE, HEAT SHRINK 0.90 DIA ADH (X 1.50" LG)	1
55	22103	SCREW, MHRD 4-40 X 0.50 ZINC	4
56	22105	WASHER, LOCK #4 ZINC-PLATED	4
57	22104	NUT, HEX 4-40 ZINC-PLATED	4
58	28919	EWB, DICH ELEC W/PT PROP, KIT	1
59	PFORM84	TEST SHEET 3612REE 7-15	1
60	PFORM134	FM INSTRUCTIONS 28790, 28791	1

**LIFTMOORE INC.**  
**CRANE ASSY 3612REE-15 WP 2ND**  
 ATB, V-MTR, HORN, DICH

PROPRIETARY AND CONFIDENTIAL INFORMATION CONTAINED IN THIS DOCUMENT IS THE SOLE PROPERTY OF LIFTMOORE INC. REPRODUCTION IN WHOLE OR AS A PART OF ANY SYSTEM WITHOUT THE WRITTEN PERMISSION OF LIFTMOORE INC. IS PROHIBITED.

MACH. PART TO BE A MINIMUM 250 RMS UNLESS SPECIFIED  
 DEFAULT TOLERANCES UNLESS SPECIFIED:  
 XX ± 0.05  
 XX ± 0.30  
 XX ± 1.00  
 XX ± .5"

FRAC ± 1/16  
 XX ± .5"

CHECKED NA 01/28/2020  
 ENG APPR NA 01/28/2020

DRAWN NA 10/09/18  
 MTRL SHEET 1 - 5  
 REV B

28951  
 DWG. NO.  
 WEIGHT: 679.37 Lbs

# LIFTMOORE INC.

CRANE ASSY 3612REE-15 WP 2ND

ATB, V-MTR, HORN, DICH

REV	B
DRAWN	INA
TO/09/18	DWG. NO.
28951	
MIRL	SHEET 2 - 5
WEIGHT	679.37 LBS

PROPRIETARY AND CONFIDENTIAL INFORMATION CONTAINED IN THIS DRAWING IS THE SOLE PROPERTY OF LIFTMOORE INC. REPRODUCTION IN WHOLE OR AS A PART OF ANY MACHINERY WITHOUT THE WRITTEN PERMISSION OF LIFTMOORE INC. IS PROHIBITED.

MACH. PART TO BE A MINIMUM 250 RMS UNLESS SPECIFIED OTHERWISE. DEFAULT TOLERANCES UNLESS SPECIFIED:  
 XX ± .05  
 XX ± .030  
 XX ± .100  
 XX ± .176  
 XX ± .5"

CHECKED	NA	01/28/2020
ENG APPR	NA	01/28/2020

NOTES  
 -REFER TO SHEET 1.

DESC: UPDATED HOT WIRE LENGTH

BY JE 01/28/2020 REV B

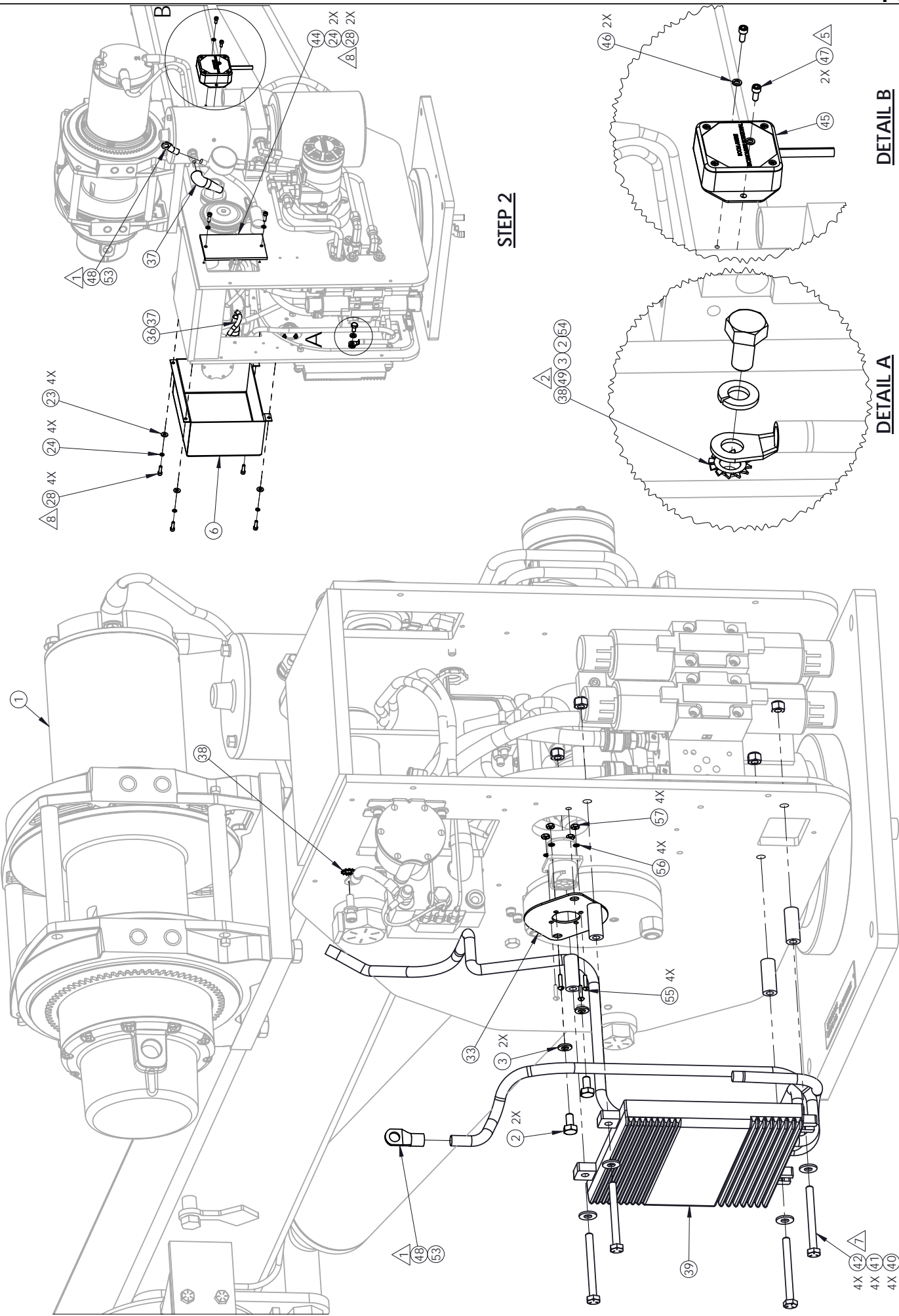

**STEP 2**

**STEP 1**

**DETAIL B**

**DETAIL A**

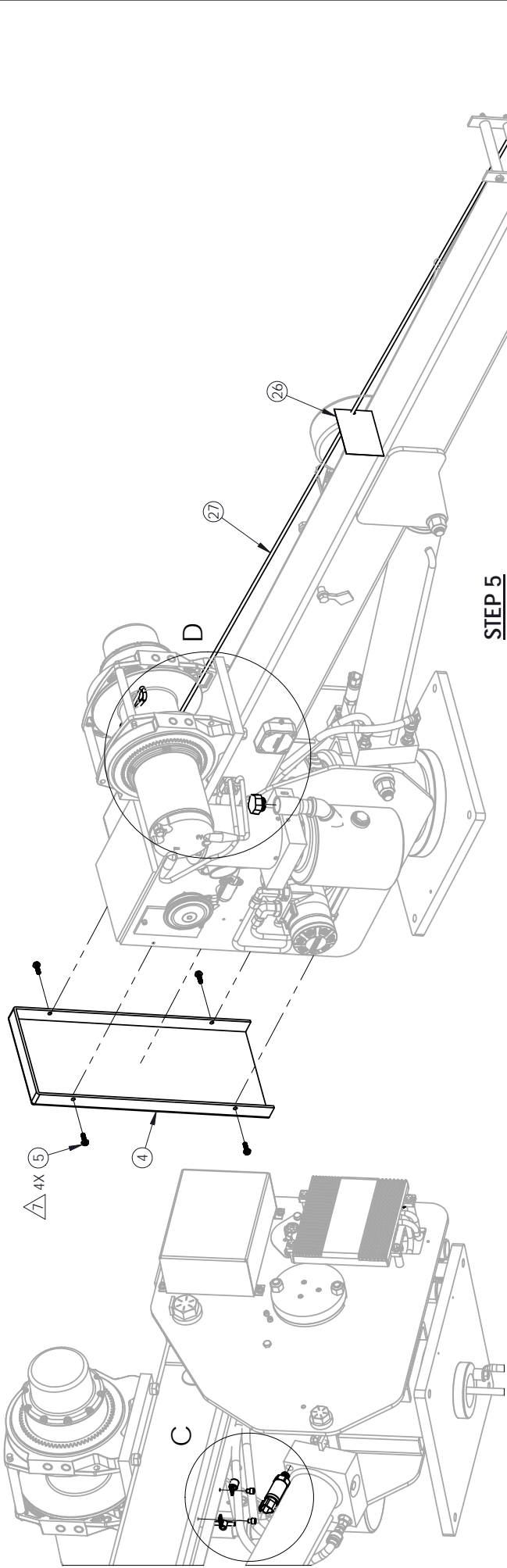

**STEP 5**

**STEP 3**

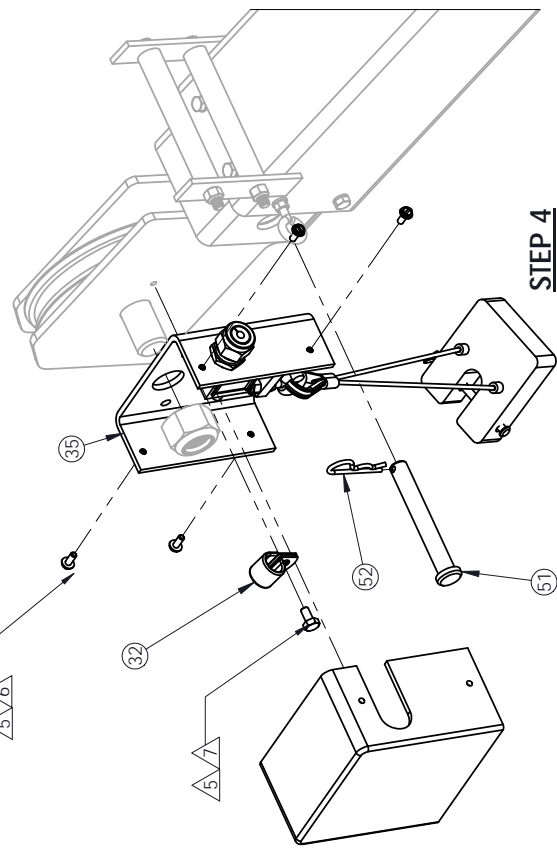

**STEP 4**

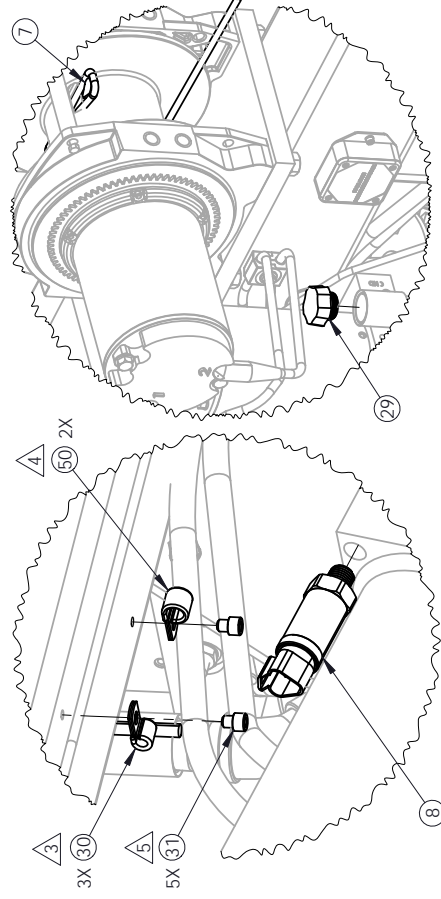

**DETAIL C**

**DETAIL D**

**PROPRIETARY AND CONFIDENTIAL**  
 INFORMATION CONTAINED IN THIS DRAWING IS THE SOLE PROPERTY OF LIFTMOORE INC.  
 REPRODUCTION IN ANY MANNER WITHOUT THE WRITTEN PERMISSION OF LIFTMOORE INC. IS PROHIBITED.

MACH. PART TO BE A MINIMUM OF 250 RMS UNLESS SPECIFIED	DATE	BY	REV
DEFAULT TOLERANCES UNLESS SPECIFIED:	01/28/2020	JE	01/28/2020
XX ± .05	FRAC	NA	10/09/18
XX ± .030	XX ± .030	NA	01/28/2020
XX ± .100	XX ± .100	NA	01/28/2020
XX ± 1/16	XX ± 1/16	NA	01/28/2020
XX ± .5"	XX ± .5"	NA	01/28/2020
CHECKED	NA	01/28/2020	01/28/2020
ENG APPR	NA	01/28/2020	01/28/2020

**LIFTMOORE INC.**  
**CRANE ASSY 3612REE-15 WP 2ND**  
 ATB, V-MTR, HORN, DICH

DRAWN	NA	10/09/18	DWG. NO.	28951
REV	NA	10/09/18	SHEET 3 - 5	B

**NOTES**  
 - REFER TO SHEET 1.

DESC: UPDATED HOT WIRE LENGTH



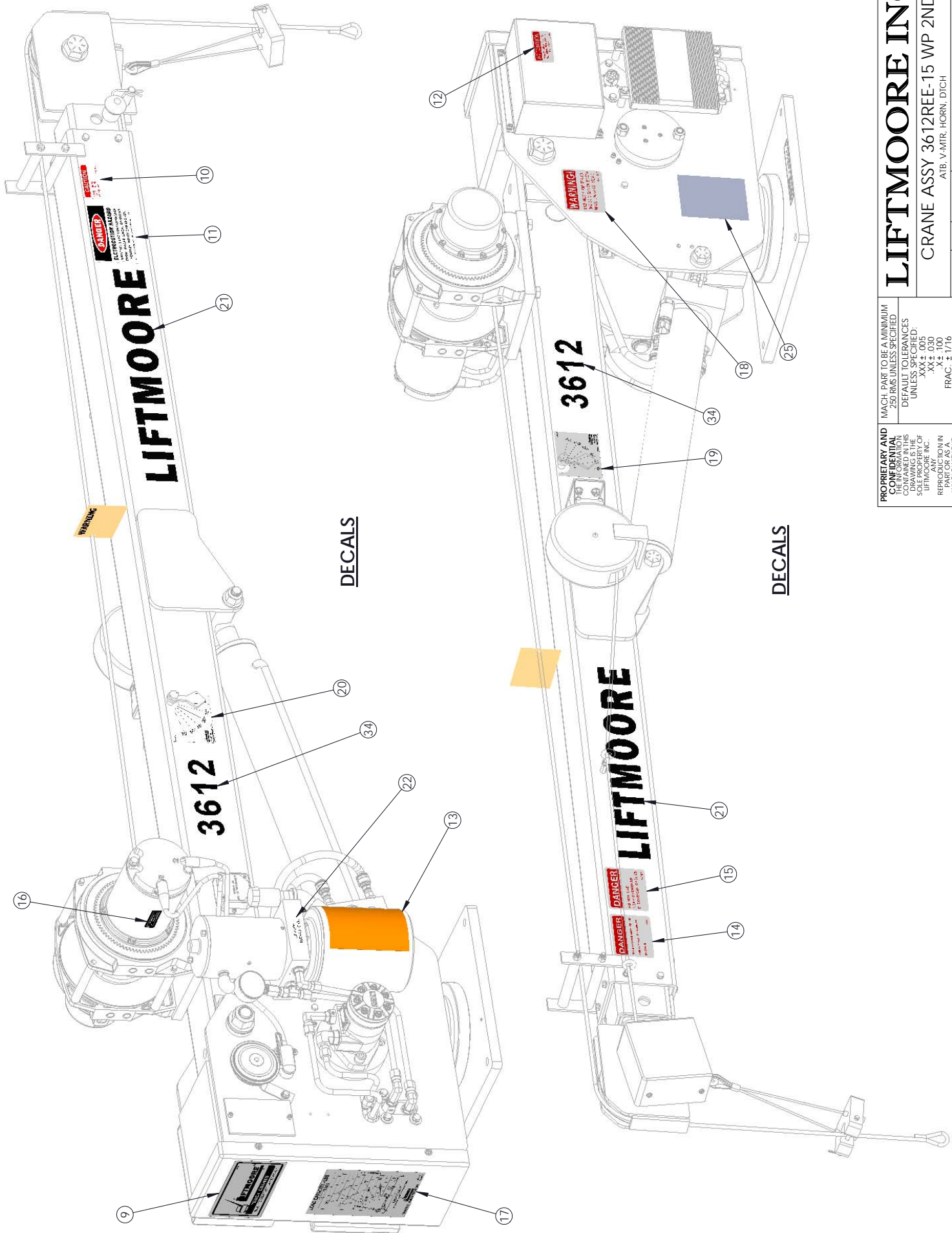

DECALS

DECALS

PROPRIETARY AND  
CONFIDENTIAL  
INFORMATION  
CONTAINED IN THIS  
DRAWING IS THE  
SOLE PROPERTY OF  
LIFTMOORE INC.  
REPRODUCTION IN  
WHOLE OR AS A  
PART OF ANY  
DRAWING WITHOUT  
THE WRITTEN  
PERMISSION OF  
LIFTMOORE INC. IS  
PROHIBITED.

MACH. PART TO BE A MINIMUM  
250 RMS UNLESS SPECIFIED  
DEFAULT TOLERANCES  
UNLESS SPECIFIED:  
XX ± .05  
XX ± .030  
XX ± .100  
FRAC ± 1/16  
XX ± .5"

CHECKED NA 01/28/2020  
ENG APPR NA 01/28/2020

DRAWN INA 10/09/18  
MTRL SHEET 4 - 5  
REV B

WEIGHT: 679.37 LBS

28951

DWG. NO. ATB, V-MTR, HORN, DICH

CRANE ASSY 3612REE-15 WP 2ND

LIFTMOORE INC.

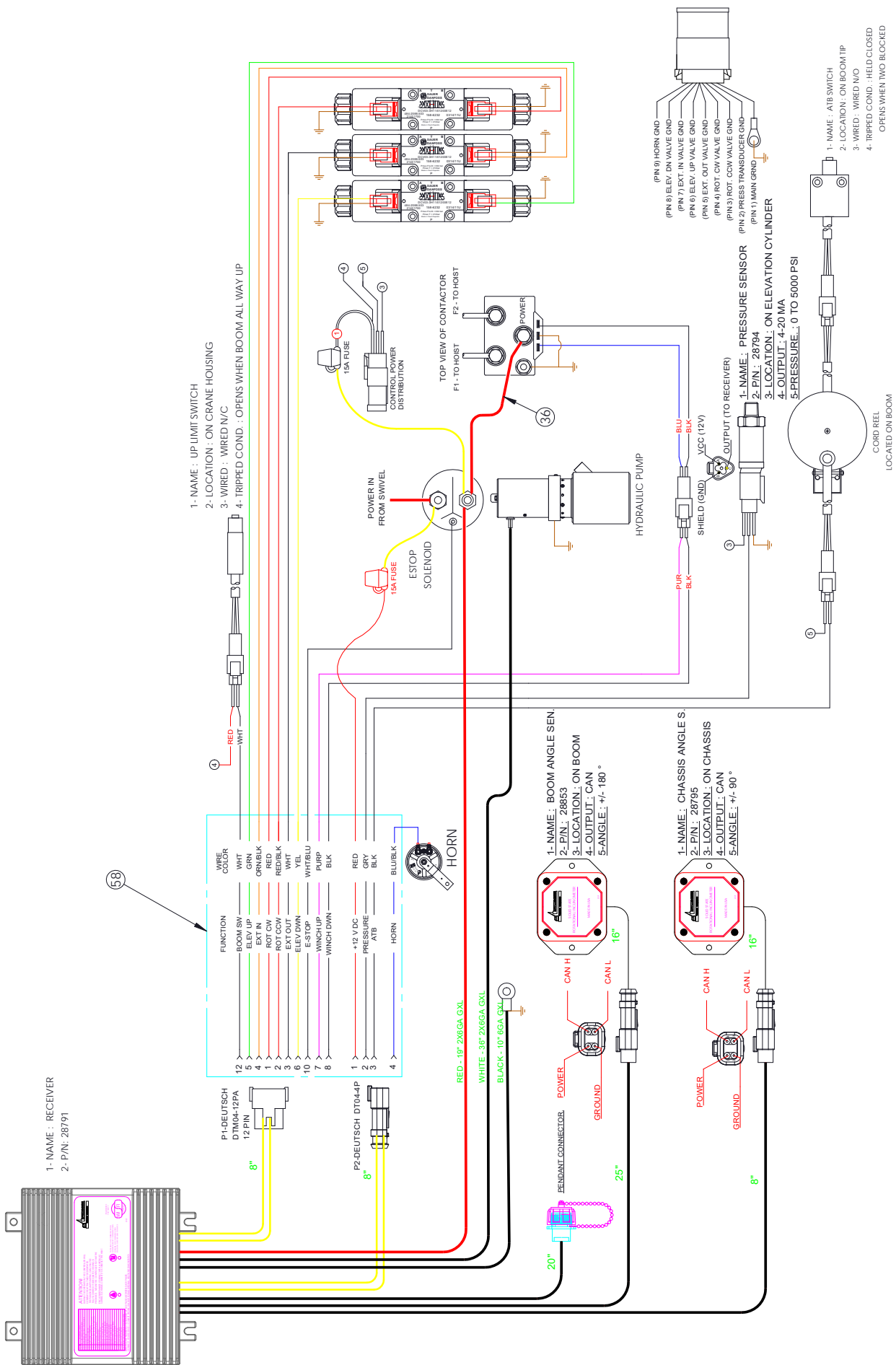

**LIFTMOORE INC.**

**CRANE ASSY 3612REE-15 WP 2ND**

ATB, V-MTR, HORN, DICH

REV B

28951

10/09/18 DWG. NO.

10/28/2020 SHEET 5 - 5

01/28/2020 WEIGHT: 679.37 LBS

01/28/2020 REV B

JE

01/28/2020 REV B

DESC: UPDATED HOT WIRE LENGTH

**PROPRIETARY AND CONFIDENTIAL**  
MACH. PART TO BE A MINIMUM OF 250 RMS UNLESS SPECIFIED  
CONTAINED IN THIS DOCUMENT UNLESS SPECIFIED OTHERWISE.  
REPRODUCTION IN WHOLE OR IN PART OR AS A COPY IS PROHIBITED WITHOUT THE WRITTEN PERMISSION OF LIFTMOORE INC.

FRAC: ± 1/16  
XX ± .5  
XX ± .5

CHECKED NA 01/28/2020  
ENGR APPR NA 01/28/2020



ITEM NO.	PART NUMBER	PART DESC	QTY.
1	28630	BOOM-BODY ASSY 2010REE-15 DTCH	1
2	24432	VALVE, 4W/3P/12V/OC DTCH	3
3	30956	SCREW, SOC HD 10-24 X 2.00	12
4	22394	PENDULUM, LOAD RADIUS DIA. HD	2
5	31017	SCREW, SHOULDER 0.31-18 X 0.75	2
6	70012	BRACKET, CORD REEL	1
7	30833	NUT, HEX NYLOC 0.25-20 GR2	2
8	31110	WASHER, FLAT 0.25 GR5 PLATED	2
9	30457	SCREW, HHC 0.25-20 X 0.75 GR5	2
10	33410	SCREW, MH RD 10-24 X 3.00	1
11	33409	NUT, HEX NYLOC 10-24 GR2	1
12	25822	REEL, CORD 20 FT ASSY DTCH	1
13	28647	ROLLER, ROPE NYLON	2
14	32638	SCREW, HHC 0.31-18 X 6.00 GR5	2
15	34468	SCREW, SHEAVE SINGLE 1-8 3.25	1
16	31258	WASHER, FLAT 1.00 SAE GRADE 8	1
17	30838	NUT, HEX NYLOC 1.00-8 GRADE 5	1
18	33058	SHEAVE ASSY 5.90PD X 0.25 ROPE	1
19	31036	STOP, BOOM INNER ASSY STD.	1
20	32968	HOSE, HYD #4 37.50"	1
21	32969	HOSE, HYD #4 44.00"	1
22	23123	PRESSURE GAUGE, 0-3000 PSI	1
23	19847	CONNECTOR, DTCH 2P PLUG	1
24	19845	CONNECTOR, DTCH 2P RECPT	1
25	19846	WEDGE, DEUTSCH 2P PLUG	1
26	19848	WEDGE, DEUTSCH 2P RECPT	1
27	31042	NUT, HEX NYLOC 0.31-18 GR2	2

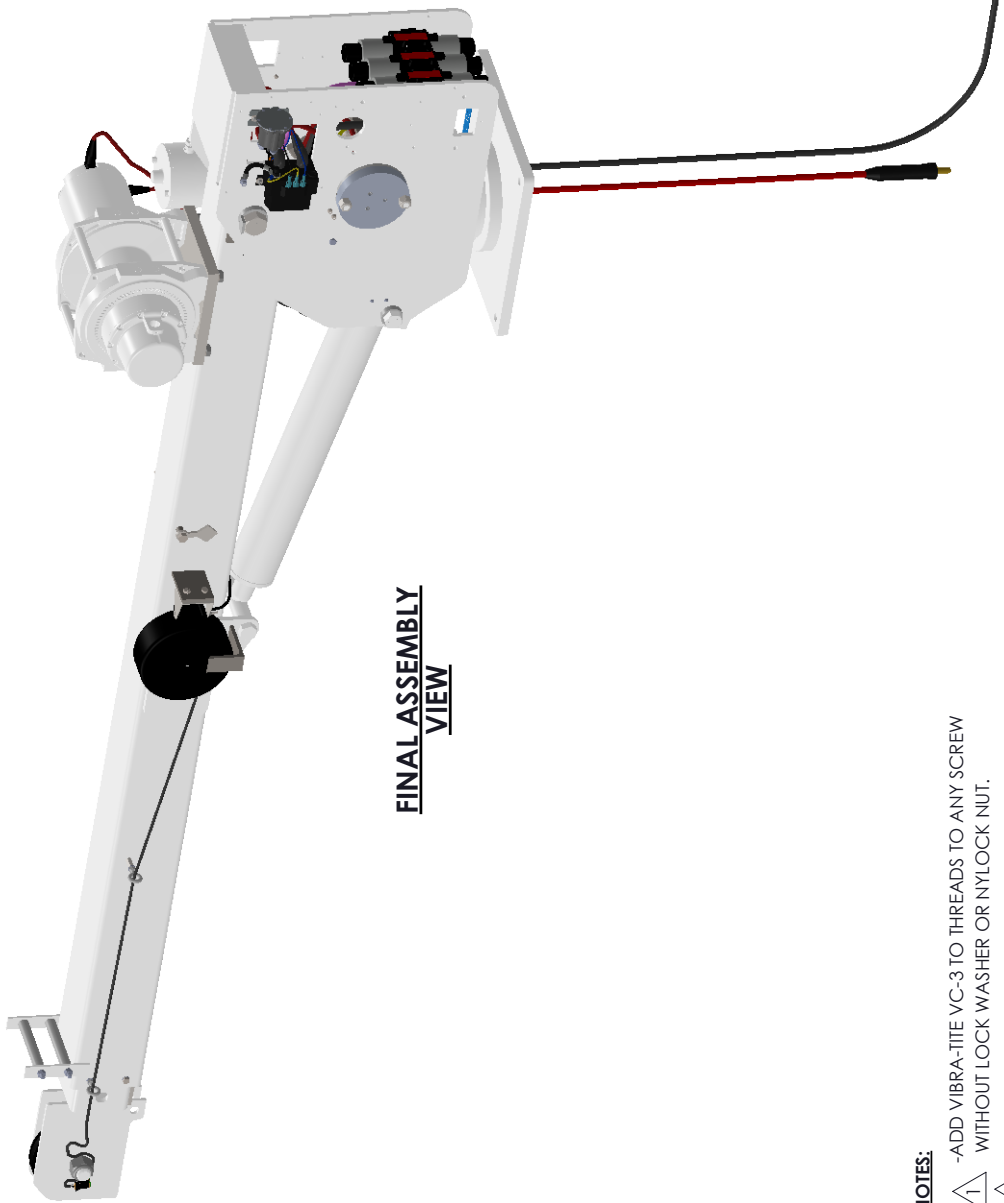

**FINAL ASSEMBLY VIEW**

**NOTES:**

- 1 -ADD VIBRA-TITE VC-3 TO THREADS TO ANY SCREW WITHOUT LOCK WASHER OR NYLOCK NUT.
- 2 -ADD TEFLON TAPE
- 3 -HAND TIGHT MAKE SURE SHEAVE SPINS FREELY.
- 4 -HAND TIGHT WITH 5/32 T-HANDLE
- 5 -HAND TIGHT.
- 6 -TORQUE TO 5 FT-Lbs.

BY JE 08/21/2019 REV F

DESC: REMOVED PUMP OVERRIDE SWITCH FROM THIS ASSEMBLY

**PROPRIETARY AND CONFIDENTIAL**  
 INFORMATION CONTAINED IN THIS DRAWING IS THE SOLE PROPERTY OF LIFTMOORE INC.  
 REPRODUCTION IN WHOLE OR IN PART WITHOUT THE WRITTEN PERMISSION OF LIFTMOORE INC. IS PROHIBITED.

MACH. PART TO BE A MINIMUM 250 RMS UNLESS SPECIFIED  
 DEFAULT TOLERANCES UNLESS SPECIFIED:  
 .XX ± .005  
 .XX ± .030  
 .XX ± .100  
 .XX ± .176  
 .XX ± .5

CHECKED NA 08/21/2019  
 ENGR APPR: DP 08/21/2019

**LIFTMOORE INC.**  
**CRANE ASSY 3612/2010REE-15 1ST**  
 ATB, VOLTMETER, HORN

DRAWN INA 7/21/2018 DWG. NO. 28579  
 MTRL: SHEET 1 - 3  
 WEIGHT: 676.9 Lbs

REV F

20) NOTE: MANIFOLD PORT B TO CYLINDER PORTE

21) NOTE: MANIFOLD PORT A TO CYLINDER PORT R

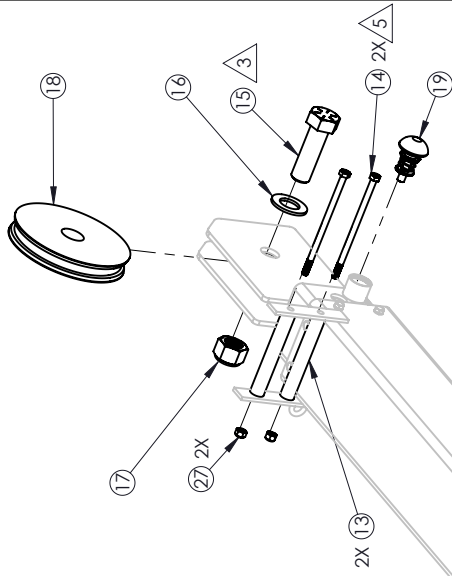

**DETAIL A**  
**ELEVATION HOSE ORIENTATION**

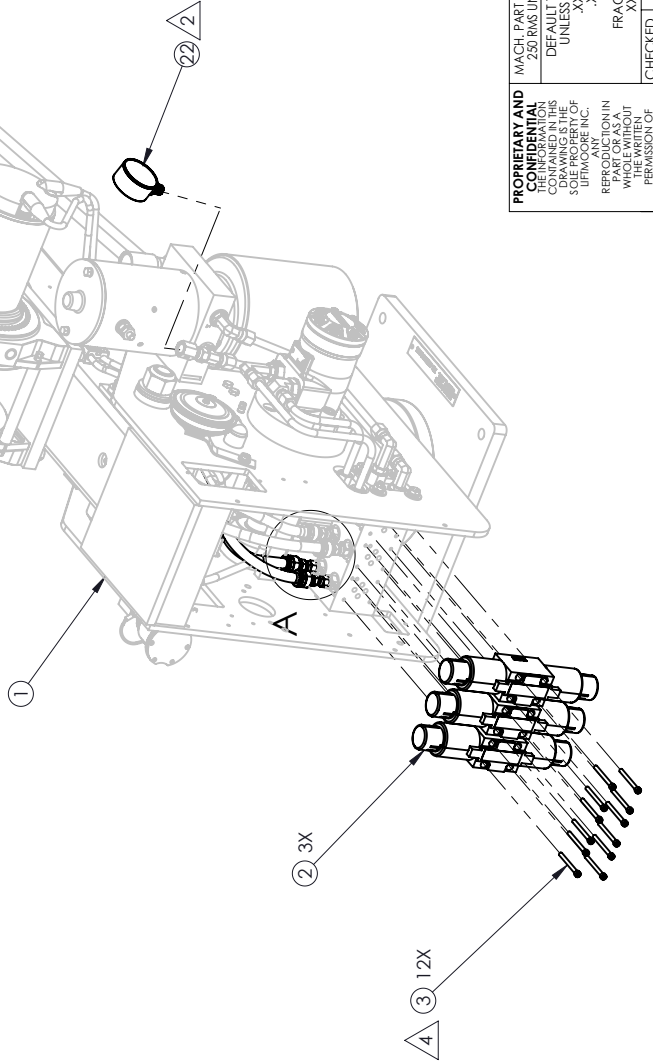
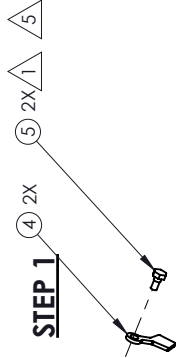
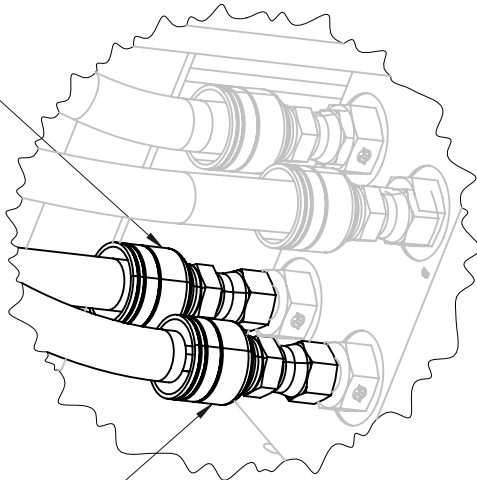

**NOTES:**

- 1 -ADD VIBRA-TITE VC-3 TO THREADS TO ANY SCREW WITHOUT LOCK WASHER OR NYLOCK NUT.
- 2 -ADD TEFLON TAPE
- 3 -HAND TIGHT MAKE SURE SHEAVE SPINS FREELY.
- 4 -HAND TIGHT WITH 5/32 T-HANDLE
- 5 -HAND TIGHT.
- 6 -TORQUE TO 5 FT-LBS.

**PROPRIETARY AND CONFIDENTIAL**  
THE INFORMATION CONTAINED IN THIS DRAWING IS THE SOLE PROPERTY OF LIFTMOORE INC. REPRODUCTION IN WHOLE OR IN PART OR AS A GUIDE FOR THE FABRICATION OF EQUIPMENT WITHOUT THE WRITTEN PERMISSION OF LIFTMOORE INC. IS PROHIBITED.

MACH. PART TO BE A MINIMUM 250 RMS UNLESS SPECIFIED	CHECKED	NA	08/21/2019	DF	08/21/2019
DEFAULT TOLERANCES UNLESS SPECIFIED: XX ± .030 X ± .100 XX ± .5°	ENG APPR:	NA	08/21/2019	DF	08/21/2019

<b>LIFTMOORE INC.</b>		DRAWN	INA	7/21/2018	DWG. NO.	28579
<b>CRANE ASSY 3612/2010REE-15 1ST</b>		MTRL:	SHEET 2 - 3		REV	F
		ATB. VOLTMETER-HORN				

DESC: REMOVED PUMP OVERRIDE SWITCH FROM THIS ASSEMBLY

BY JE 08/21/2019 REV F

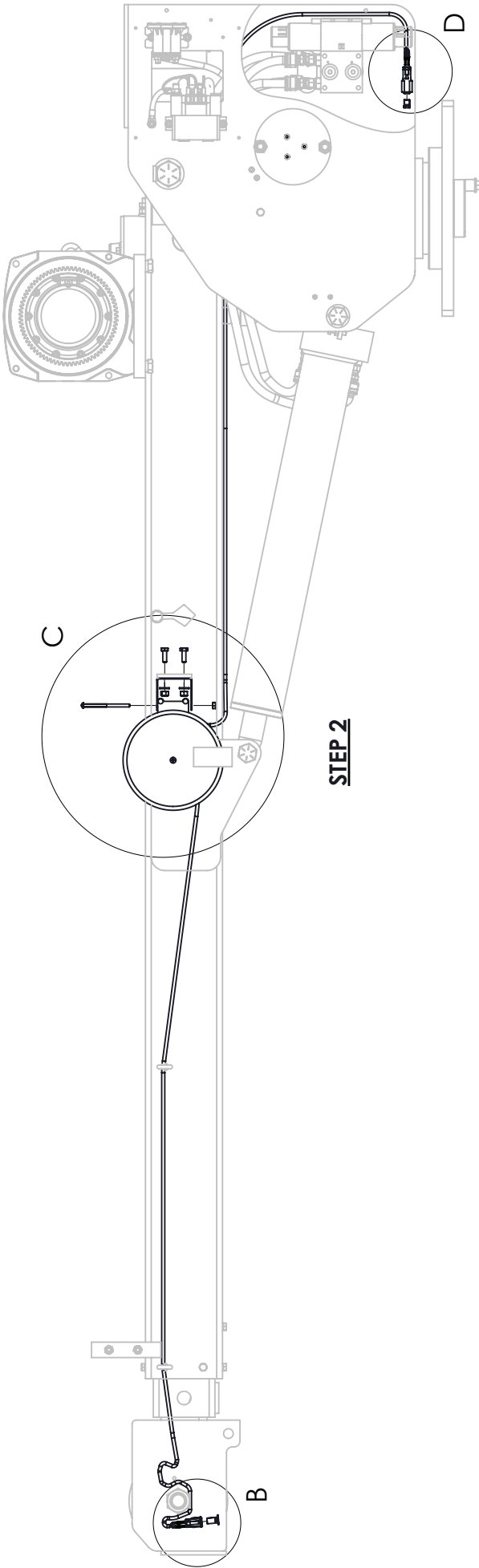

**STEP 2**

**WIRE SEQUENCE**  
 WHITE - PIN 1  
 BLACK - PIN 2

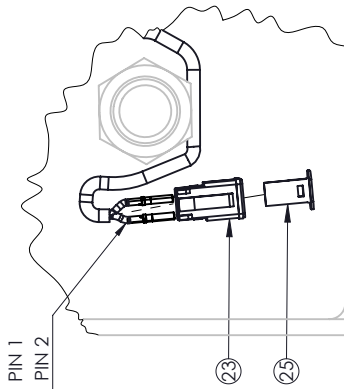

**DETAIL B**

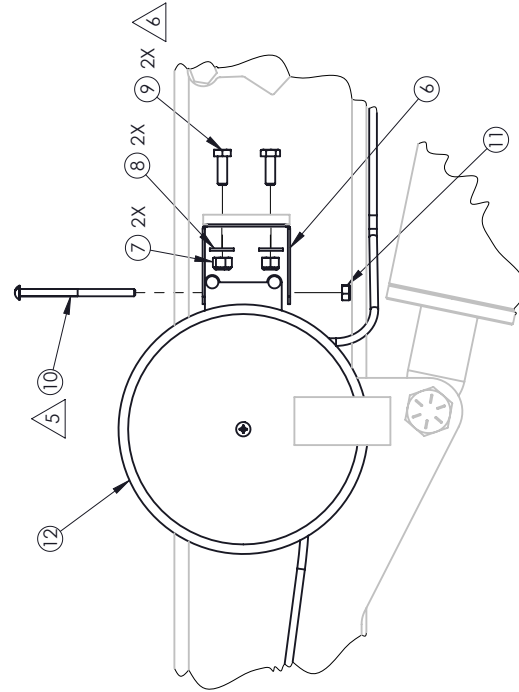

**DETAIL C**

**WIRE SEQUENCE**  
 WHITE - PIN 1  
 BLACK - PIN 2

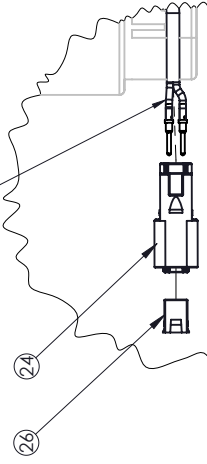

**DETAIL D**

**NOTES:**

- 1 -ADD VIBRA-TITE VC-3 TO THREADS TO ANY SCREW WITHOUT LOCK WASHER OR NYLOCK NUT.
- 2 -ADD TEFLON TAPE
- 3 -HAND TIGHT MAKE SURE SHEAVE SPINS FREELY.
- 4 -HAND TIGHT WITH 5/32 T-HANDLE
- 5 -HAND TIGHT.
- 6 -TORQUE TO 5 FT-Lbs.

**PROPRIETARY AND CONFIDENTIAL**  
 INFORMATION CONTAINED IN THIS DRAWING IS THE SOLE PROPERTY OF LIFTMOORE INC.  
 REPRODUCTION IN WHOLE OR IN PART WITHOUT THE WRITTEN PERMISSION OF LIFTMOORE INC. IS PROHIBITED.

MACH. PART TO BE A MINIMUM 250 RMS UNLESS SPECIFIED  
 DEFAULT TOLERANCES UNLESS SPECIFIED:  
 .XX ± .005  
 .XX ± .030  
 .X ± .100  
 .X ± .176  
 .XX ± .5  
 CHECKED: NA 08/21/2019  
 ENG APPR: DF 08/21/2019

<b>LIFTMOORE INC.</b>		CRANE ASSY 3612/2010REE-15 1ST	ATB, VOLTMETER, HORN
DRAWN: NA	7/21/2018	DWG. NO.	28579
MTRL: SHEET 3 - 3		REV	F
WEIGHT: 676.9 L Bds			

NOTE: WIRE SHOULD BE SECURED TO SHEAVE BOLT TO ENSURE THAT IT DOES NOT INTERFERE WITH THE LEVER

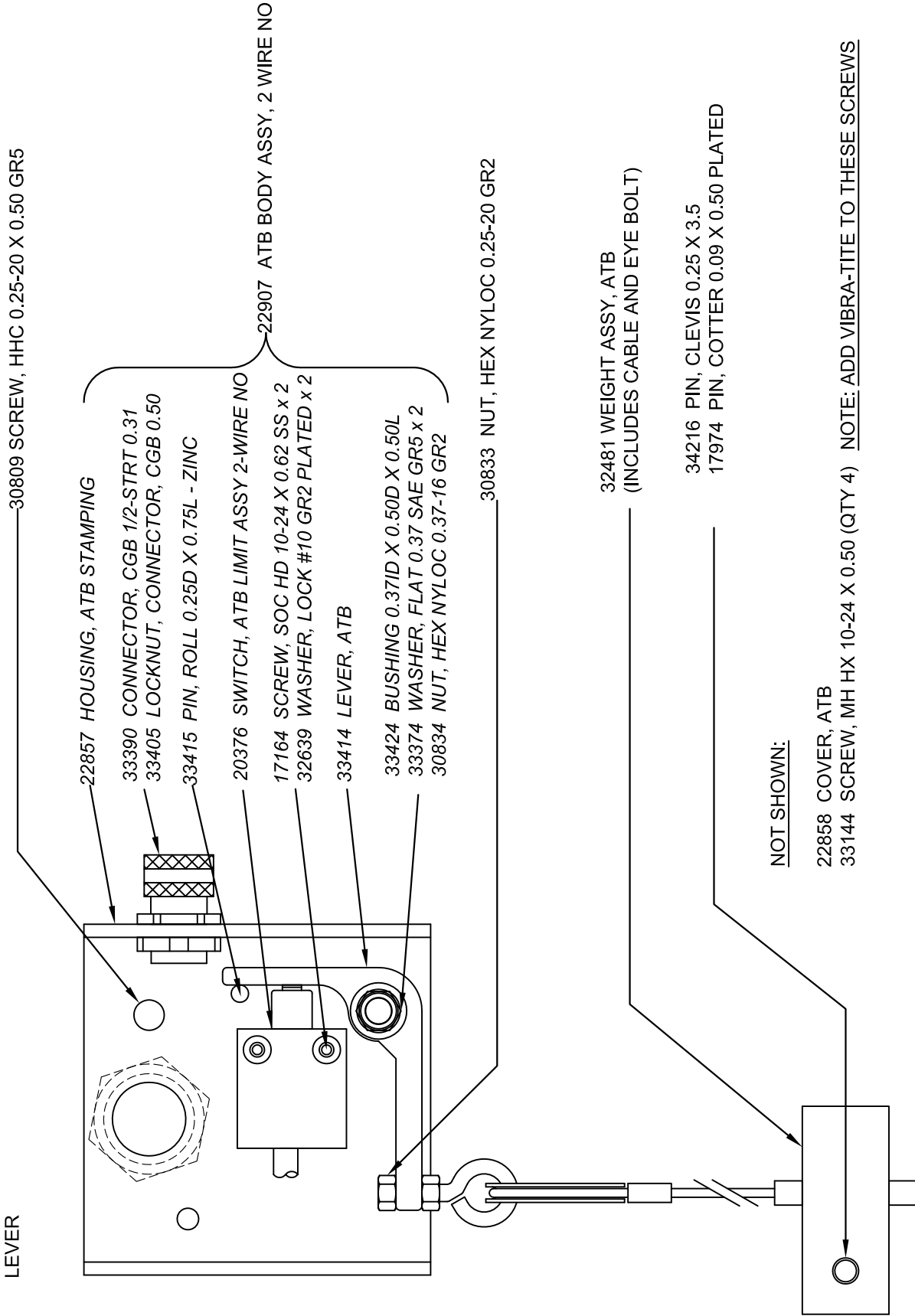

Houston TX  
(713)-688-5533  
www.iftmoore.com

DRWN BY: JC  
DATE: 07/02/09

ATB ASSY, DEUTSCH CONN  
TWO-WIRE NORMAL OPEN; LEFT SIDE

DRAWING NO.

22908-B

ITEM NO.	PART NUMBER	PART DESC	QTY.
1	28568	BOOM ASSEMBLY 2010REE-15 ATB	1
2	28629	BODY ASSEMBLY 2010REE	1
3	21209	CYLINDER ASSY 3200 ELEV DTCH	1
4	30477	WASHER, FLAT 0.75 GR5 SAE PL.	3
5	33127	SCREW, HHC 0.75-10 X 10 GR8	1
6	30836	NUT, HEX NYLOC 0.75-10 GRADE 5	2
7	31258	WASHER, FLAT 1.00 SAE GRADE 8	2
8	26581	SCREW, HHC 1.00-8 X 10.0 GR8	1
9	30838	NUT, HEX NYLOC 1.00-8 GRADE 5	1
10	30464	SCREW, HHC 0.75-10 X 7.00 GR8	1
11	70009	BOOT, RUBBER 1 & 1/0	2
12	PF0RM16	CHECKLIST FORM	1

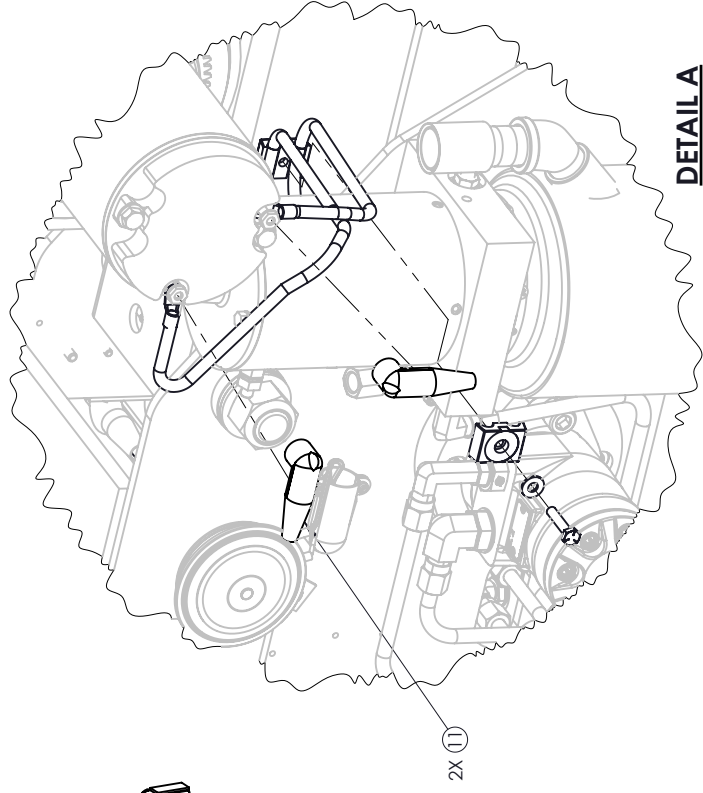
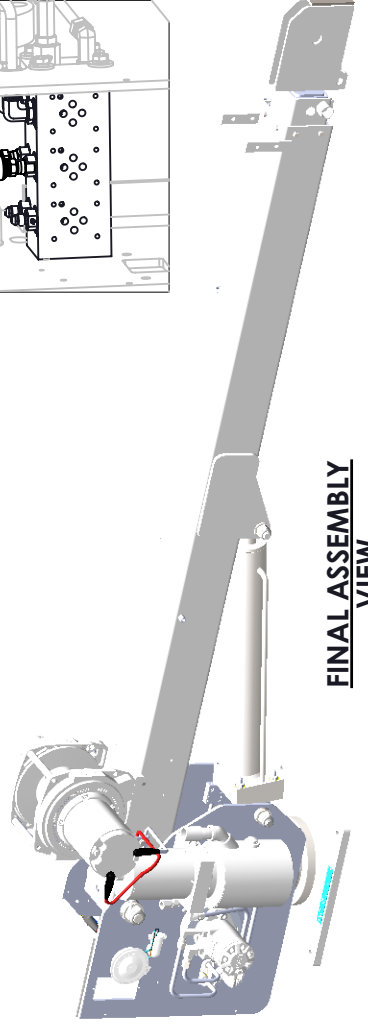
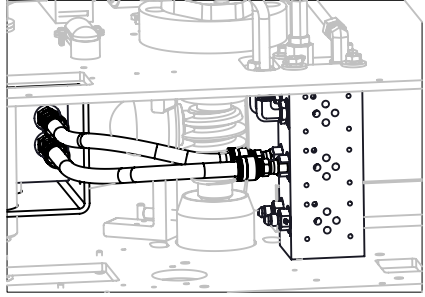
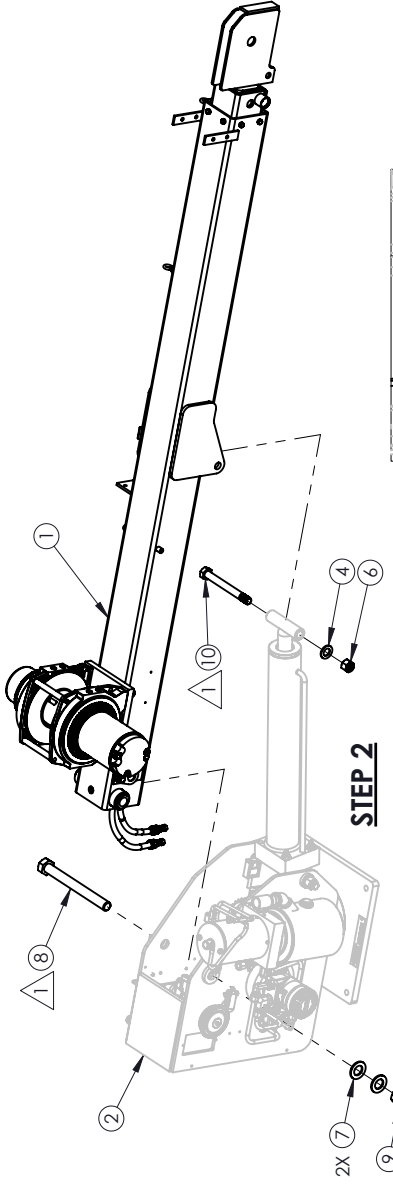
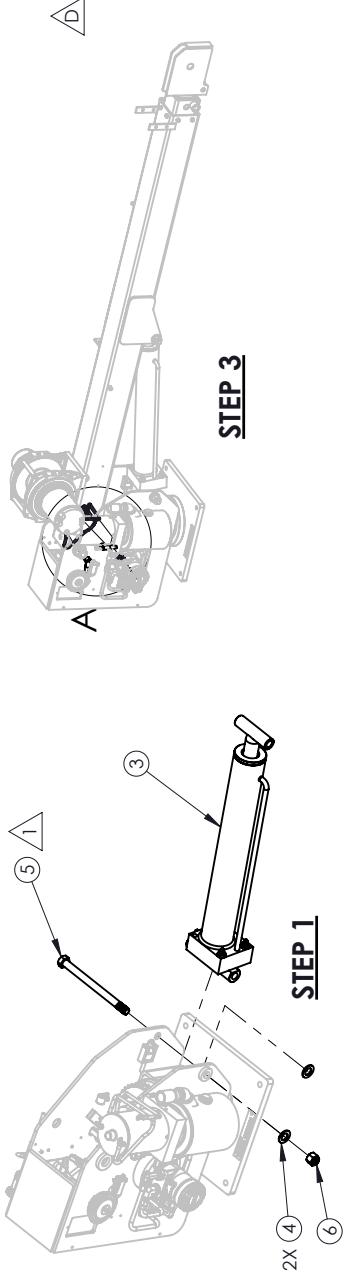

**NOTE:**  
 USE IMPACT GUN SET ON SETTING 2 W/115 PSI TO TIGHTEN. CHECK TO MAKE SURE SCREWS CAN BE TURNED WITH A WRENCH AFTER TIGHTENING TO AVOID OVER TIGHTENING.  
 DISC: REVISED DRAWING TO REFLECT THE ACTUAL BODY ASSEMBLY

**PROPRIETARY AND CONFIDENTIAL:** INFORMATION CONTAINED IN THIS DRAWING IS THE SOLE PROPERTY OF LIFTMOORE INC. REPRODUCTION IN WHOLE OR AS A PART OF ANY SYSTEM WITHOUT THE WRITTEN PERMISSION OF LIFTMOORE INC. IS PROHIBITED.

MACH. PART TO BE A MINIMUM 250 RMS UNLESS SPECIFIED  
 DEFAULT TOLERANCES UNLESS SPECIFIED:  
 XX ± .005  
 XX ± .030  
 XX ± .100  
 XX ± .50  
 FRACTION: 1/16  
 CHECKED: NA 08/19/2019  
 ENG APPR: DF 08/19/2019

**LIFTMOORE INC.**  
**BOOM-BODY ASSY 2010REE-15 DTCH**

DRAWN: \_\_\_\_\_ DWG. NO. 286630  
 MTRL: \_\_\_\_\_ SHEET 1 - 1  
 WEIGHT: 657.21 Lbs

REV C

FOR PRESSURE SWITCH PART NUMBER SEE CRANE ASSEMBLY DRAWING

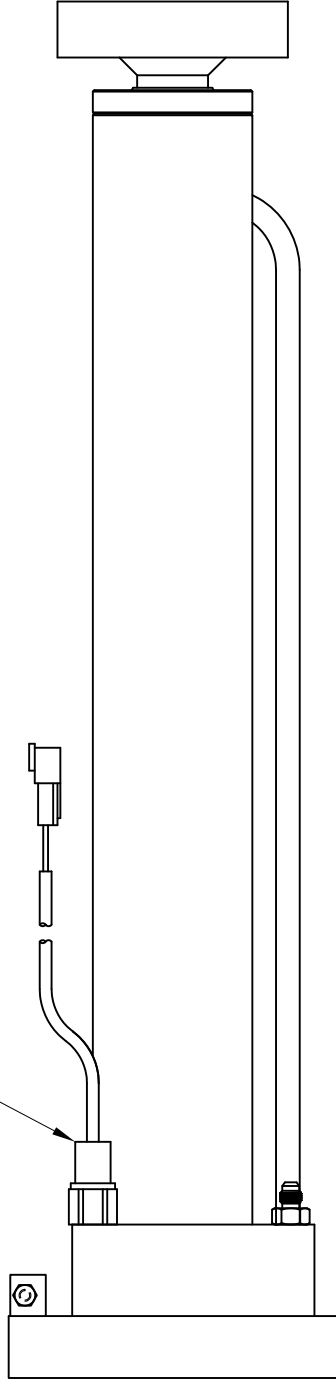

REPLACEMENT PARTS FOR CYLINDER	
DESCRIPTION	PART NUMBER
SEAL KIT	TM*SK-0000148
COUNTER BALANCE VALVE	30851

P/N 32400  
ADAPTER, 4MJ-6MO  
2 PLCS

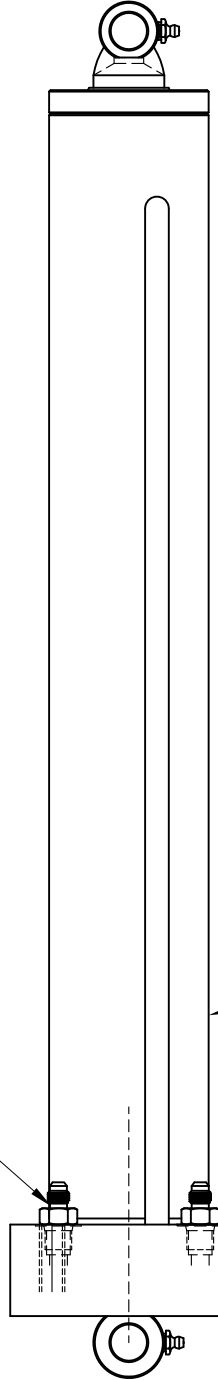

P/N 32867  
CYLINDER, 3.0 X 18.5 X 1.25 PE

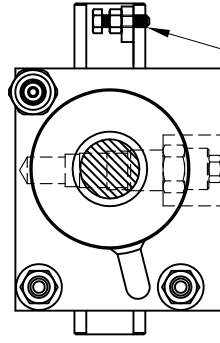

P/N 30810  
SCREW, HHC 0.25-20 X 1.00 GR5

P/N 30830  
NUT, HEX 0.25-20 GR2 PLATED

FOR UPLIMIT SWITCH



Houston TX  
(713)-688-5533  
www.iftmoore.com

DRWN BY: JC

DATE: 1/31/08

CYLINDER ASSY 3200 ELEV DTCH

DRAWING NO.

21209-C

# LIFTMOORE INC.

## BODY ASSEMBLY 2010RCE

PROPRIETARY AND CONFIDENTIAL INFORMATION CONTAINED IN THIS DRAWING IS THE SOLE PROPERTY OF LIFTMOORE INC. REPRODUCTION IN WHOLE OR AS A PART OF ANY MANNER WITHOUT THE WRITTEN PERMISSION OF LIFTMOORE INC. IS PROHIBITED.

MACH. PART TO BE A MINIMUM 250 RMS UNLESS SPECIFIED OTHERWISE. DEFAULT TOLERANCES UNLESS SPECIFIED:  
 .XX ± .030  
 .XX ± .100  
 .XX ± .5"

REV	C
DRAWN	INA
MIRL	SHEET 1 - 5
DWG. NO.	28629
CHECKED	NA
DATE	08/19/2019
ENG APPR.	DP
WEIGHT:	279.59 Lbs

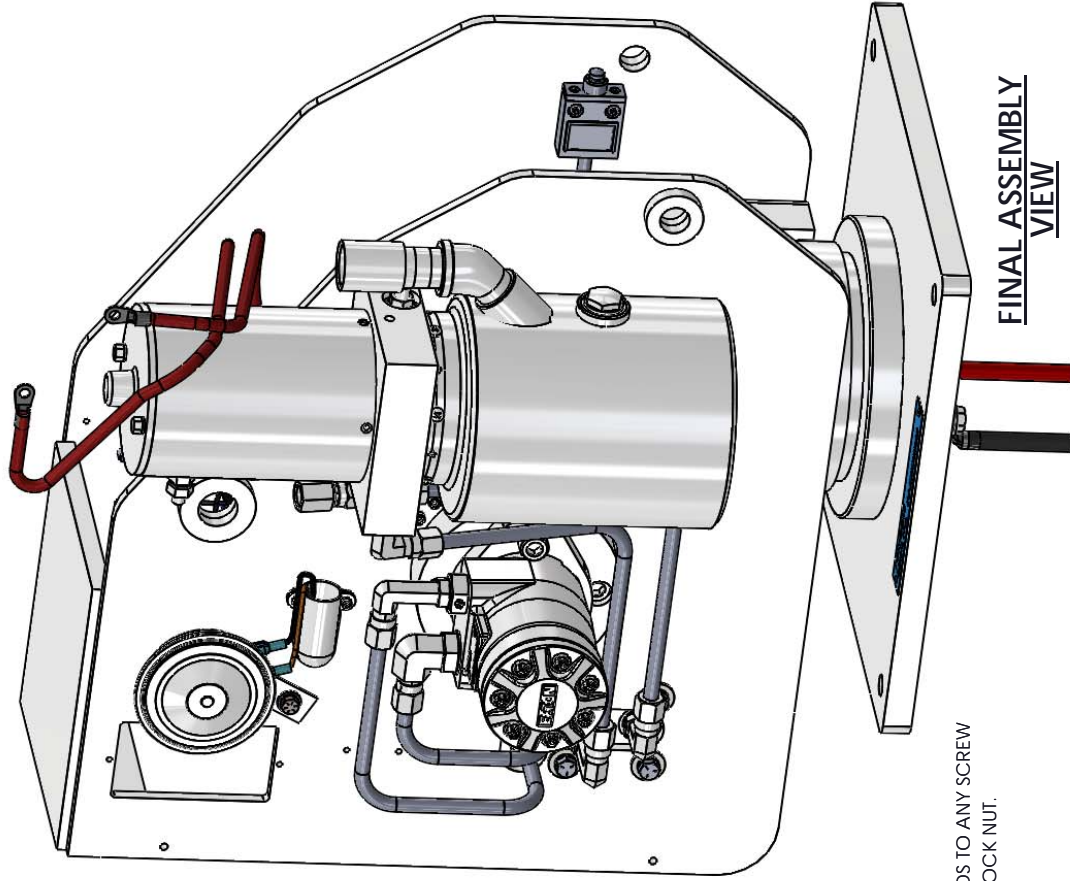

**FINAL ASSEMBLY VIEW**

- NOTES:**
- 1 - ADD VIBRA-TITE VC-3 TO THREADS TO ANY SCREW WITHOUT LOCK WASHER OR NYLOCK NUT.
  - 2 - TORQUE TO 4 FT-Lbs.
  - 3 - TORQUE TO 5 FT-Lbs.
  - 4 - TORQUE TO 30 FT-Lbs.
  - 5 - TORQUE TO 20 FT-Lbs.
  - 6 - USE GE SILICONE 1.
  - 7 - USE LOCITITE 565 ON THREADS.
  - 8 - MILITARY GREASE PM600.
  - 9 - HAND TIGHT 5/32 T-HANDLE.
  - 10 - HAND TIGHT 8"-11/16 WRENCH.
  - 11 - HAND TIGHT 7"-7/16 WRENCH.
  - 12 - HAND TIGHT FLAT HEAD SCREW DRIVER.

ITEM NO.	PART NUMBER	Part Desc	QTY.
1	28626	BASE-HOUSING ASSY 2010	1
2	24698	SOLENOID, SINGLE POLE 12V I/G	1
3	WI 34038	CONTACTOR, DP SEALED	1
4	20413	SWITCH, LIMIT UP 2WNC-22 DITCH	1
5	23051	HORN, 108 DB	1
6	17164	SCREW, SOC HD 10-24 X 0.62 SS	4
7	32639	WASHER, LOCK #10 GR2 PLATED	4
8	33145	WASHER, FLAT #10 GR2 PLATED	4
9	24552	MANIFOLD ASSY 3612RCE #6/#6 BO	1
10	30859	SCREW, HHC 0.31-18 X 1.00 GR5	4
11	30888	WASHER, FLAT 0.31 GR5 PLATED	4
12	30890	WASHER, LOCK 0.31 GR5 PLATED	4
13	31738	SCREW, MH RD 6-32 X 1.00	2
14	31123	NUT, HEX 6-32 GR2 PLATED	2
15	33606	WASHER, FLAT #6 GR2 PLATED	2
16	31124	WASHER, LOCK #6 GR2 PLATED	2
17	30457	SCREW, HHC 0.25-20 X 0.75 GR5	4
18	30889	WASHER, LOCK 0.25 GR5 PLATED	2
19	31110	WASHER, FLAT 0.25 GR5 PLATED	2
20	32957	CLAMP, HOSE SUPPORT 0.62 ID	1
21	30810	SCREW, HHC 0.25-20 X 1.00 GR5	3
22	30833	NUT, HEX NYLOC 0.25-20 GR2	3
23	33258	BRACKET, ANGLE SWIVEL ASSY3200	1
24	27850	SCREW, SOC HD 0.25-20 X 0.75SS	1
25	24553	TUBE, HYD MOTOR 3612 OUTER	1
26	24554	TUBE, HYD MOTOR 3612 INNER	1
27	23136	PUMP ASSEMBLY 3200 MONARCH	1
28	24657	TUBE, HYD PUMP 3612 SUPPLY	1
29	24658	TUBE, HYD PUMP 3612 RETURN	1
30	22034	ADAPTER, STREET ELBOW 3/4" 45D	1
31	18392	ADAPTER, NIPPLE 2.00" LG 12-12	1
32	32866	ADAPTER, 12FP-12FP X 3/4"	1
33	30813	SCREW, HHC 0.37-16 X 1.00 GR8	2
34	25904	WASHER, SERRATED 0.37 ZINC PL.	2
35	33002	SWIVEL, ELEC ASSY 3200/2700A	1
36	22831	COVER, SWIVEL ELECTRIC	1
37	32164	NUT, HEX ACORN 0.25-20 GRADE 2	1
38	30791	WIRE, BATTERY #6 X 3.50' W/IRM	1
39	28596	WIRE, BATTERY #4 X 23' W/TERMS	1
40	28595	WIRE, WINCH #6 X 41' (F2)	1
41	28594	WIRE, WINCH #6 X 44' (F1)	1
42	30674	BOOT, RUBBER 1 & 1/0	2
43	20344	EWH, CONTACTOR DITCH	1
44	25651	EWH, HORN EXTENSION	1
45	15159	CLAMP, CABLE T&B 1/2" ELBOW	1



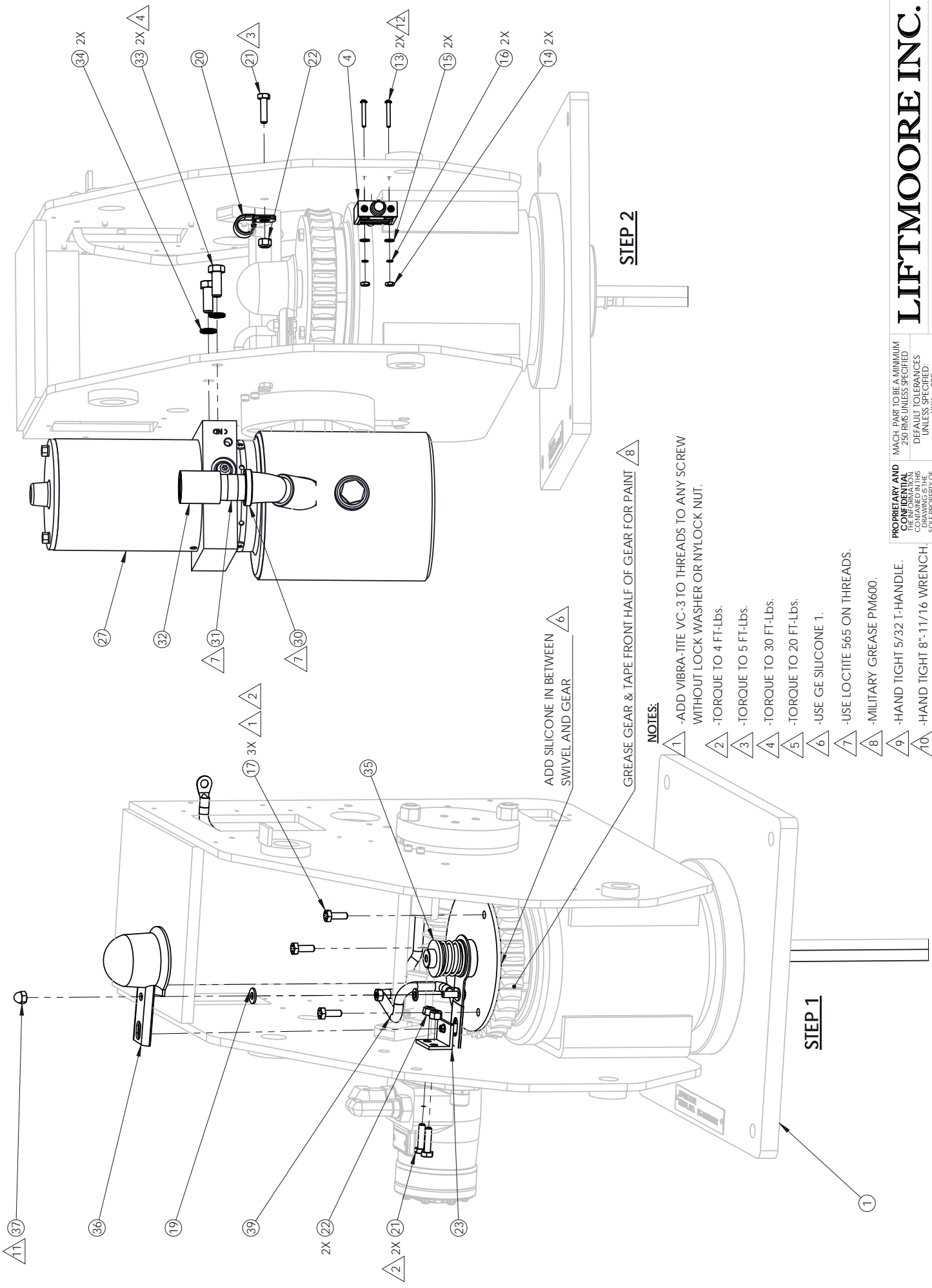

**STEP 2**

**STEP 1**

**NOTES:**

- 1 -ADD VIBRA-TITE VC-3 TO THREADS TO ANY SCREW WITHOUT LOCK WASHER OR NYLOCK NUT.
- 2 -TORQUE TO 4 FT-Lbs.
- 3 -TORQUE TO 5 FT-Lbs.
- 4 -TORQUE TO 30 FT-Lbs.
- 5 -TORQUE TO 20 FT-Lbs.
- 6 -USE GE SILICONE 1.
- 7 -USE LOCTITE 565 ON THREADS.
- 8 -MILITARY GREASE PM600.
- 9 -HAND TIGHT 5/32 T-HANDLE.
- 10 -HAND TIGHT 8"-11/16 WRENCH.
- 11 -HAND TIGHT 7"-7/16 WRENCH.
- 12 -HAND TIGHT FLAT HEAD SCREW DRIVER.

<b>PROPRIETARY AND CONFIDENTIAL</b>		MACH. PART TO BE A MINIMUM 250 RMS UNLESS SPECIFIED	
CONTAINED IN THIS DOCUMENT IS THE SOLE PROPERTY OF LIFTMOORE INC.		DEFAULT TOLERANCES UNLESS SPECIFIED:	
REPRODUCTION IN WHOLE OR AS A PART OF ANY MANNER WITHOUT THE WRITTEN PERMISSION OF LIFTMOORE INC. IS PROHIBITED.		XX ± .030	
		XX ± .030	
		XX ± .100	
		XX ± .5"	
CHECKED	NA	08/19/2019	DP
ENG APPR.	NA	08/19/2019	DP
DRAWN	NA		
MTRL.		SHEET 2 - 5	
REV		DWG. NO.	28629
		WEIGHT: 279.59 Lbs	

**LIFTMOORE INC.**  
**BODY ASSEMBLY 2010RE**



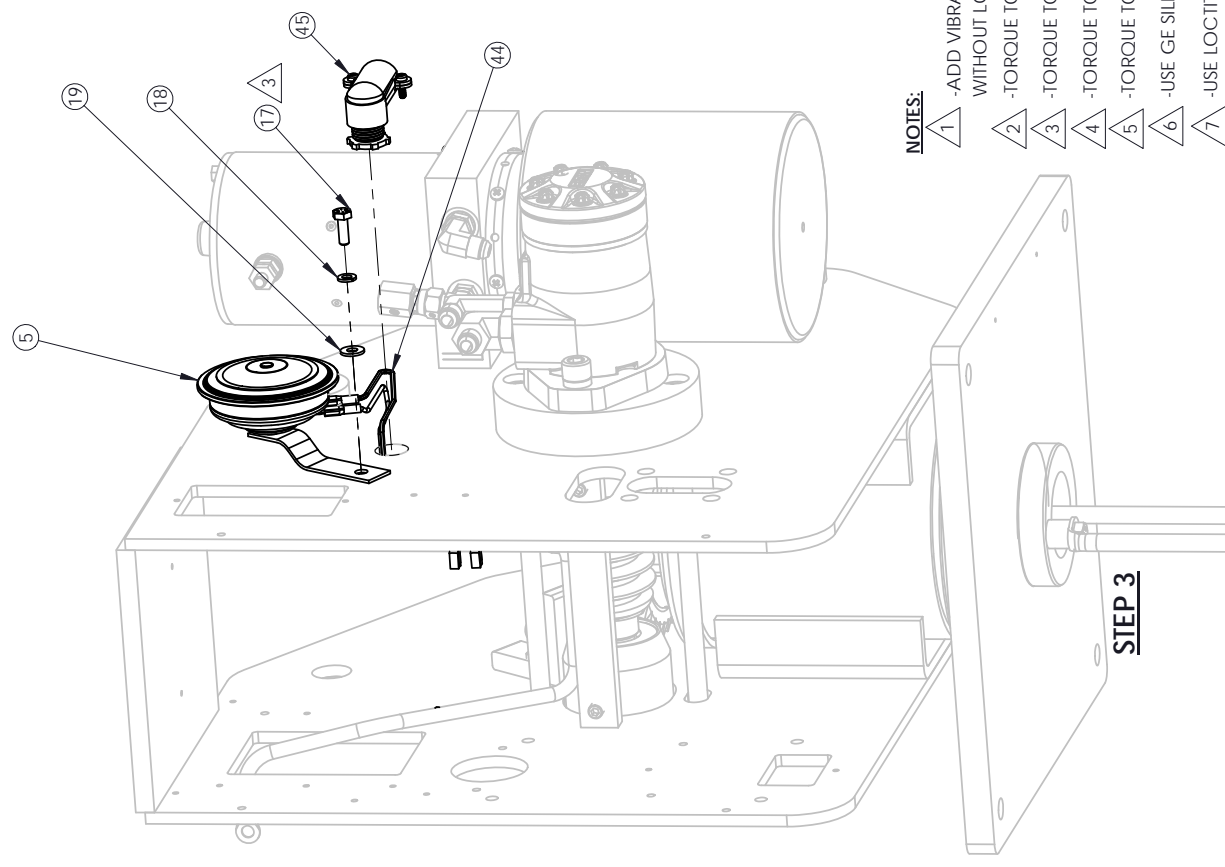
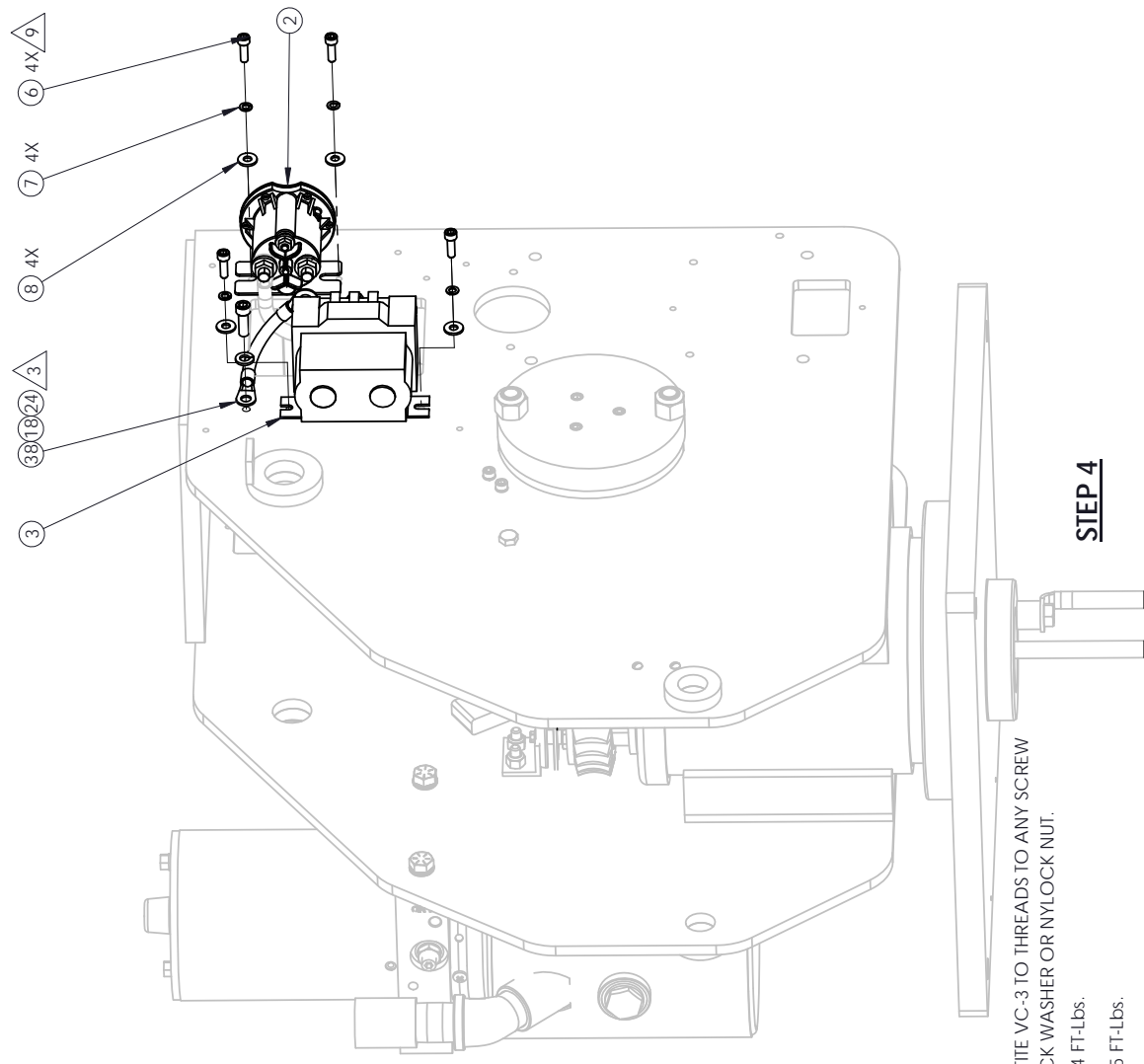

**NOTES:**

- 1 -ADD VIBRA-TITE VC-3 TO THREADS TO ANY SCREW WITHOUT LOCK WASHER OR NYLOCK NUT.
- 2 -TORQUE TO 4 FT-Lbs.
- 3 -TORQUE TO 5 FT-Lbs.
- 4 -TORQUE TO 30 FT-Lbs.
- 5 -TORQUE TO 20 FT-Lbs.
- 6 -USE GE SILICONE 1.
- 7 -USE LOCTITE 565 ON THREADS.
- 8 -MILITARY GREASE PM600.
- 9 -HAND TIGHT 5/32 T-HANDLE.
- 10 -HAND TIGHT 8"-11/16 WRENCH.
- 11 -HAND TIGHT 7"-7/16 WRENCH.
- 12 -HAND TIGHT FLAT HEAD SCREW DRIVER.

**STEP 4**

**STEP 3**

**LIFTMOORE INC.**  
**BODY ASSEMBLY 2010REE**

MACH. PART TO BE A MINIMUM 250 RMS UNLESS SPECIFIED  
 TOLERANCES TO UNLESS SPECIFIED  
 UNLESS SPECIFIED:  
 .XX ± .030  
 .XX ± .100  
 XX ± .5"

FRAC ± 1/16  
 XX ± .5"

CHECKED NA 08/19/2019  
 MTRL: SHEET 3 - 5  
 ENG APPR DP 08/19/2019 WEIGHT: 279.59 Lbs

DRAWN NA DWG. NO. 28629  
 REV C

PROPRIETARY AND CONFIDENTIAL INFORMATION CONTAINED IN THIS DRAWING IS THE SOLE PROPERTY OF LIFTMOORE INC. REPRODUCTION IN WHOLE OR AS A PART OF ANY MANNER WITHOUT THE WRITTEN PERMISSION OF LIFTMOORE INC. IS PROHIBITED.

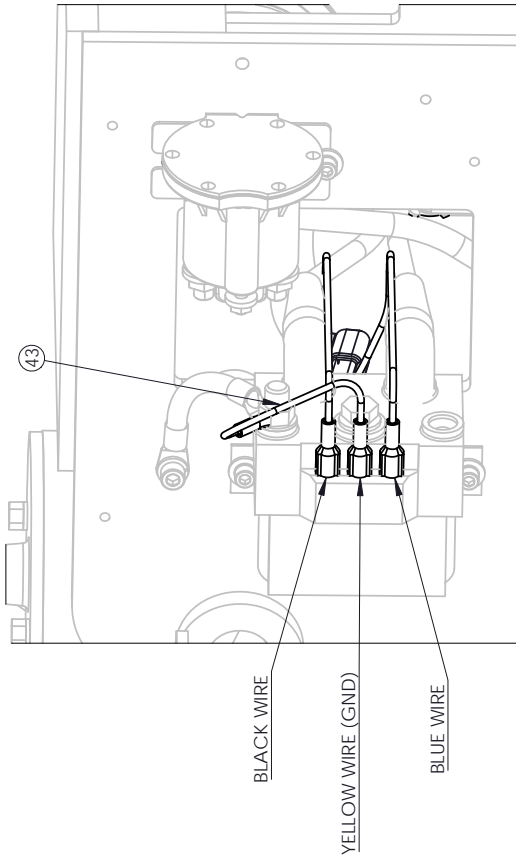

**STEP 6**

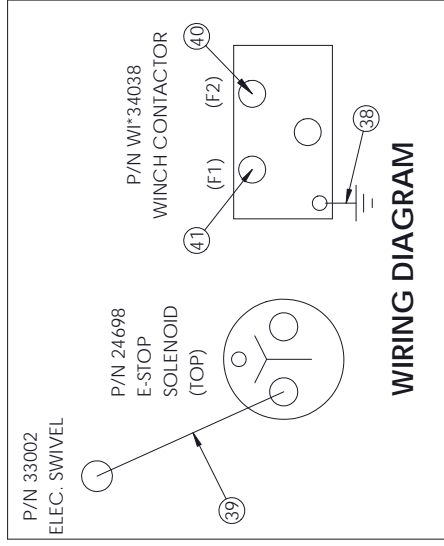

**NOTES:**

- 1 -ADD VIBRA-TITE VC-3 TO THREADS TO ANY SCREW WITHOUT LOCK WASHER OR NYLOCK NUT.
- 2 -TORQUE TO 4 FT-Lbs.
- 3 -TORQUE TO 5 FT-Lbs.
- 4 -TORQUE TO 30 FT-Lbs.
- 5 -TORQUE TO 20 FT-Lbs.
- 6 -USE GE SILICONE 1.
- 7 -USE LOCTITE 565 ON THREADS.
- 8 -MILITARY GREASE PM600.
- 9 -HAND TIGHT 5/32 T-HANDLE.
- 10 -HAND TIGHT 8"-11/16 WRENCH.
- 11 -HAND TIGHT 7"-7/16 WRENCH.
- 12 -HAND TIGHT FLAT HEAD SCREW DRIVER.

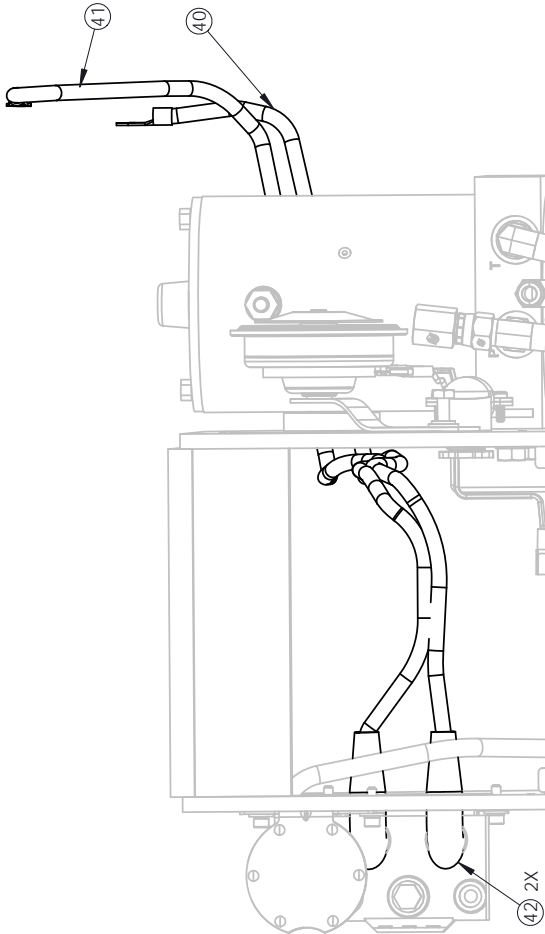

**STEP 5**

PROPRIETARY AND CONFIDENTIAL INFORMATION CONTAINED IN THIS DRAWING IS THE SOLE PROPERTY OF LIFTMOORE INC. REPRODUCTION IN PART OR AS A WHOLE WITHOUT THE WRITTEN PERMISSION OF LIFTMOORE INC. IS PROHIBITED.

MACH. PART TO BE A MINIMUM 250 RMS UNLESS SPECIFIED OTHERWISE. DEFAULT TOLERANCES UNLESS SPECIFIED: .XX ± .030 .XX ± .100 .XX ± .5"

CHECKED NA 08/19/2019  
 ENG APPR DP 08/19/2019

DRAWN INA  
 MTRL: SHEET 4 - 5  
 DWG. NO. 28629  
 WEIGHT: 279.59 Lbs

**LIFTMOORE INC.**  
**BODY ASSEMBLY 2010REE**

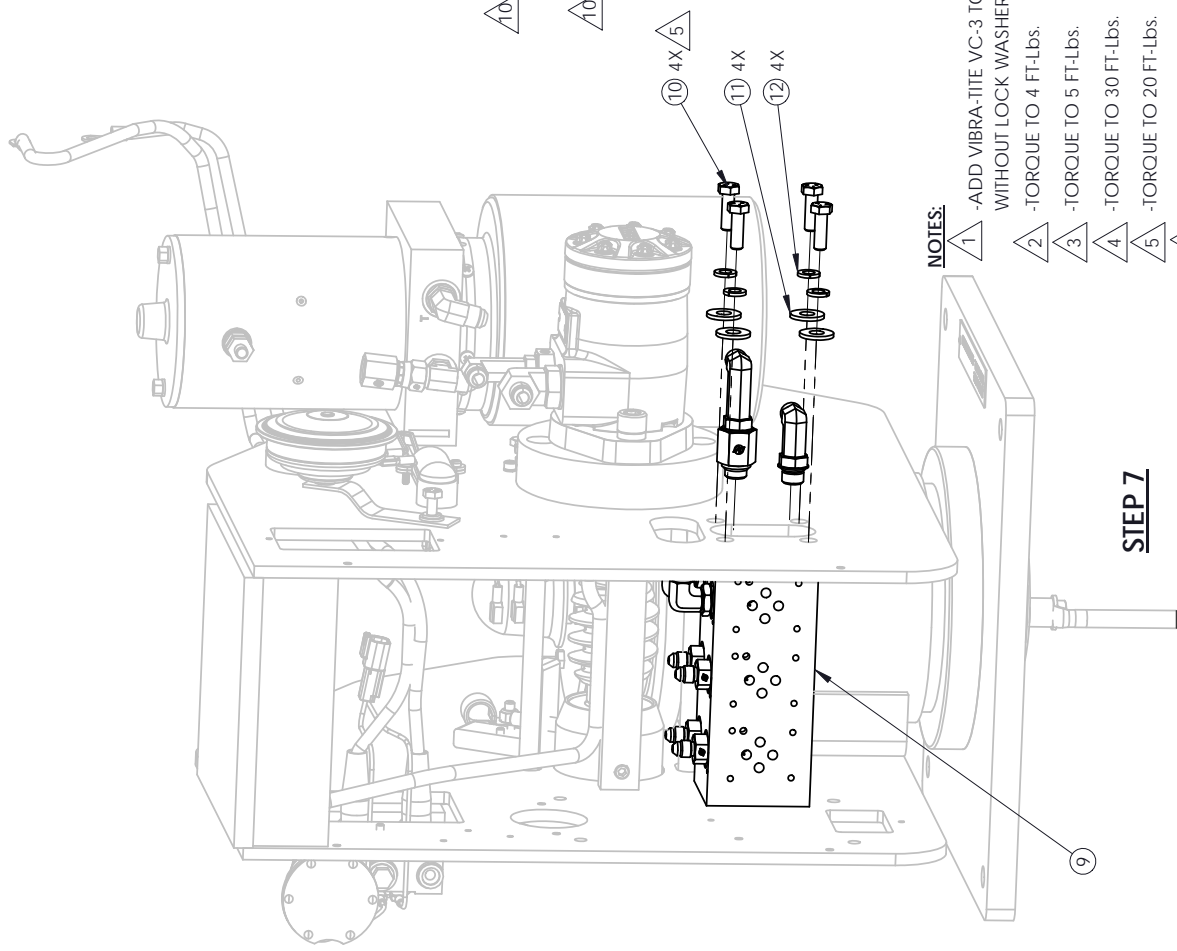

**STEP 7**

**NOTES:**

- 1 -ADD VIBRA-TITE VC-3 TO THREADS TO ANY SCREW WITHOUT LOCK WASHER OR NYLOCK NUT.
- 2 -TORQUE TO 4 FT-Lbs.
- 3 -TORQUE TO 5 FT-Lbs.
- 4 -TORQUE TO 30 FT-Lbs.
- 5 -TORQUE TO 20 FT-Lbs.
- 6 -USE GE SILICONE 1.
- 7 -USE LOCTITE 565 ON THREADS.
- 8 -MILITARY GREASE PM600.
- 9 -HAND TIGHT 5/32 T-HANDLE.
- 10 -HAND TIGHT 8"-11/16 WRENCH.
- 11 -HAND TIGHT 7"-7/16 WRENCH.
- 12 -HAND TIGHT FLAT HEAD SCREW DRIVER.

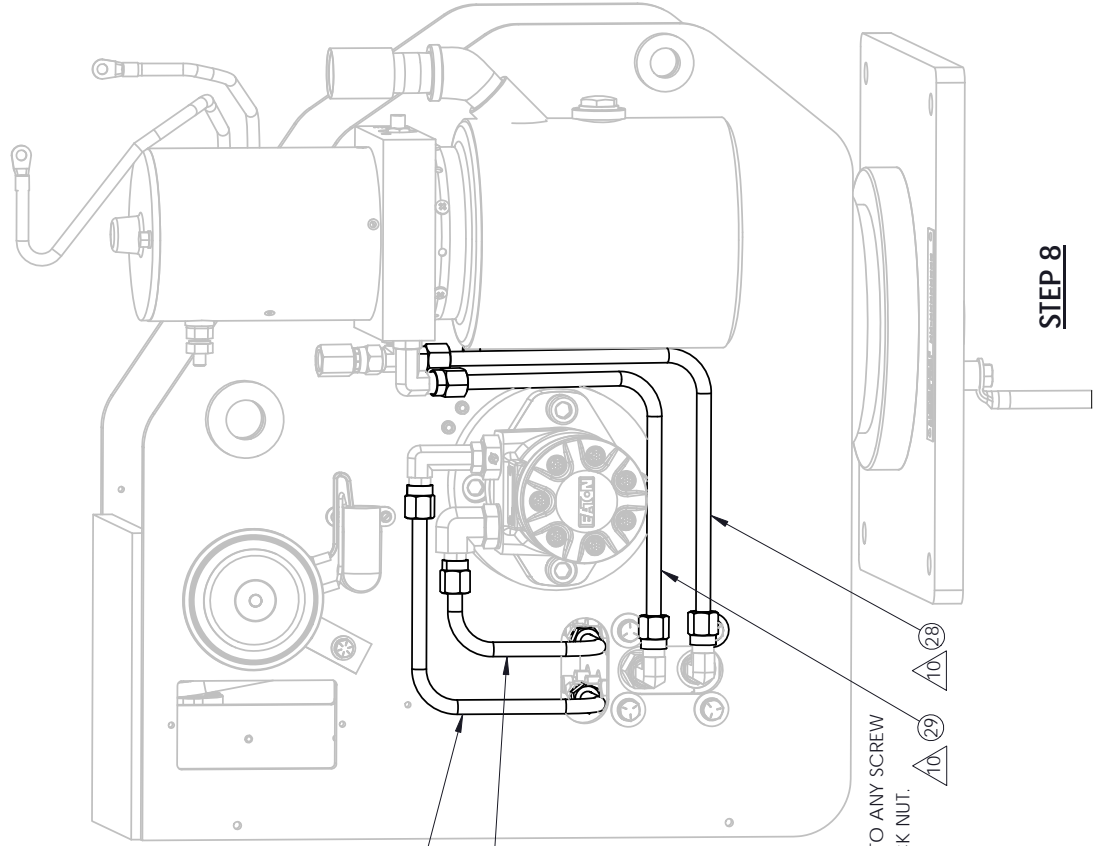

**STEP 8**

PROPRIETARY AND CONFIDENTIAL INFORMATION CONTAINED IN THIS DRAWING IS THE SOLE PROPERTY OF LIFTMOORE INC. REPRODUCTION IN WHOLE OR AS A PART OF ANY MANNER WITHOUT THE WRITTEN PERMISSION OF LIFTMOORE INC. IS PROHIBITED.

MACH. PART TO BE A MINIMUM 250 RMS UNLESS SPECIFIED TO THE CONTRARY. DEFAULT TOLERANCES UNLESS SPECIFIED:  
 .XX ± .030  
 .X ± .100  
 XX ± .5"  
 FRAC ± 1/16  
 XX ± .5"

CHECKED NA 08/19/2019  
 MTRL: NA  
 DRAWN NA  
 DWG. NO. 28629  
 REV C

LIFTMOORE INC.  
 BODY ASSEMBLY 2010REE

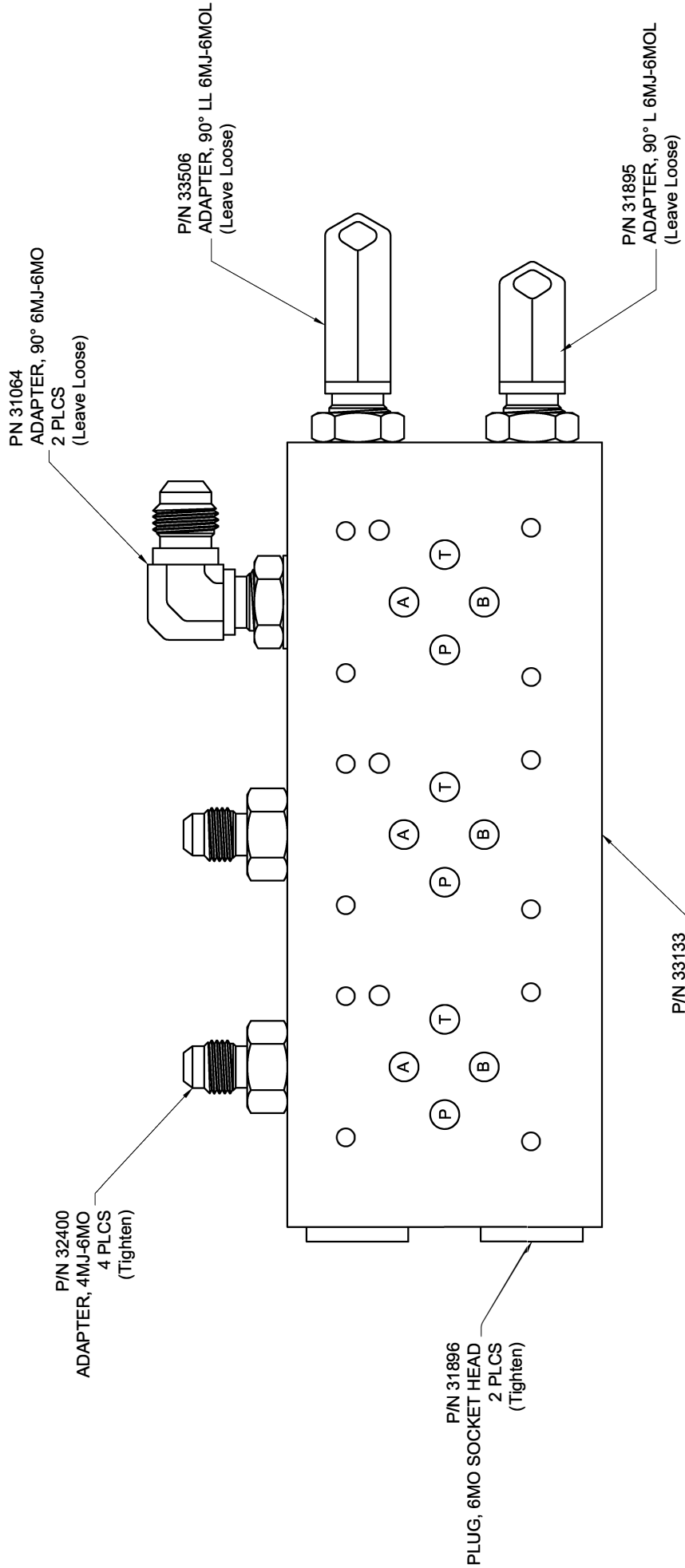

DRAWING NO. 22168-B

MANIFOLD ASSY 3200REE #6/#6 BO

DRWN BY: RLC

DATE: 8/28/06

Houston TX  
(713)-688-5533  
www.liftmoore.com



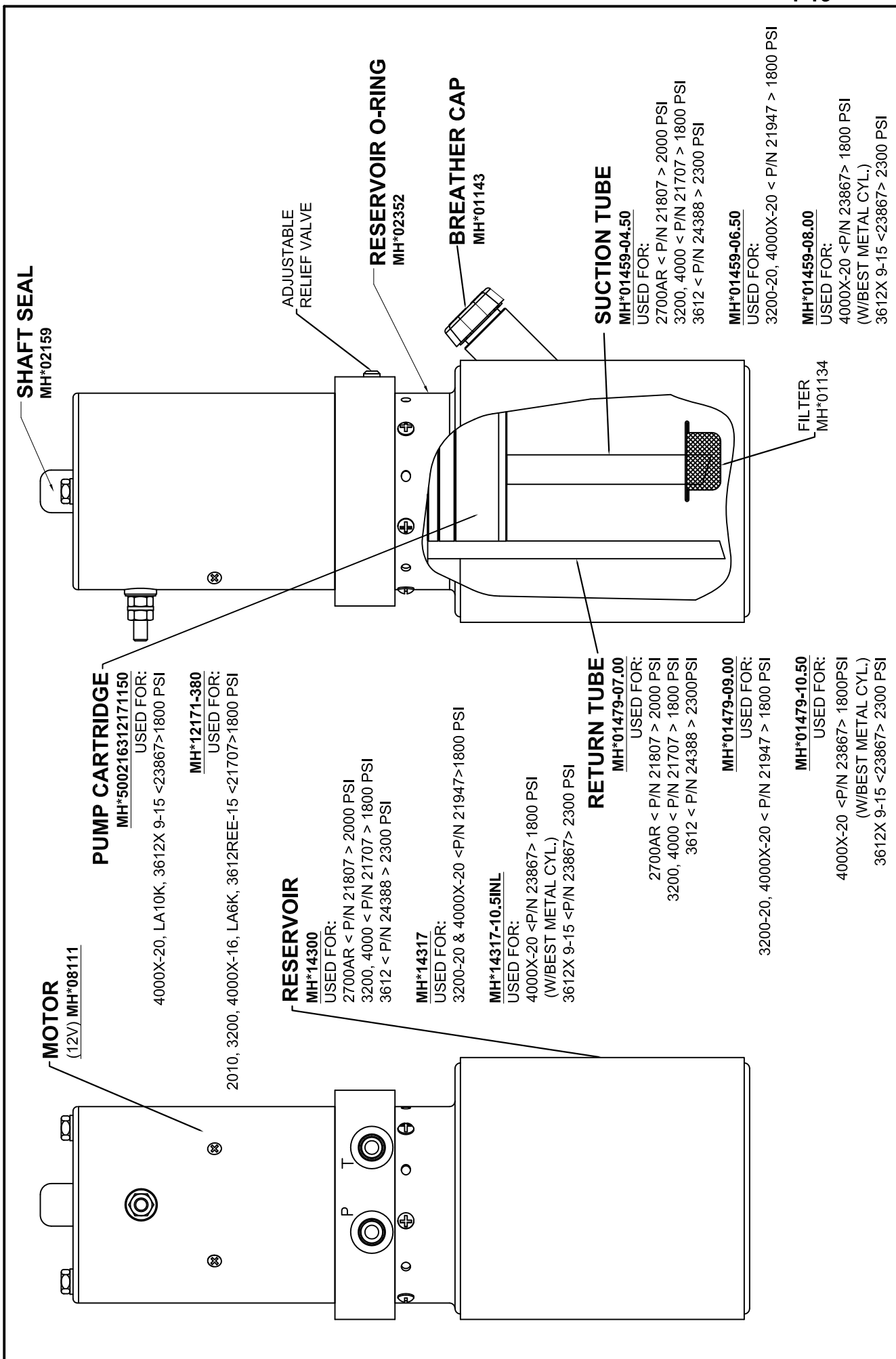

**SHAFT SEAL**  
MH\*02159

**PUMP CARTRIDGE**

**MH\*500216312171150**  
USED FOR:  
4000X-20, LA10K, 3612X 9-15 <23867>1800 PSI

**MH\*12171-380**  
USED FOR:  
2010, 3200, 4000X-16, LA6K, 3612FREE-15 <21707>1800 PSI

**RESERVOIR**

**MH\*14300**  
USED FOR:  
2700AR < P/N 21807 > 2000 PSI  
3200, 4000 < P/N 21707 > 1800 PSI  
3612 < P/N 24388 > 2300 PSI

**MH\*14317**  
USED FOR:  
3200-20 & 4000X-20 <P/N 21947>1800 PSI

**MH\*14317-10.5INL**  
USED FOR:  
4000X-20 <P/N 23867> 1800 PSI  
(W/BEST METAL CYL.)  
3612X 9-15 <P/N 23867> 2300 PSI

**RETURN TUBE**

**MH\*01479-07.00**  
USED FOR:  
2700AR < P/N 21807 > 2000 PSI  
3200, 4000 < P/N 21707 > 1800 PSI  
3612 < P/N 24388 > 2300PSI

**MH\*01479-09.00**  
USED FOR:  
3200-20, 4000X-20 < P/N 21947 > 1800 PSI

**MH\*01479-10.50**

USED FOR:  
4000X-20 <P/N 23867> 1800PSI  
(W/BEST METAL CYL.)  
3612X 9-15 <23867> 2300 PSI

**SUCTION TUBE**

**MH\*01459-04.50**  
USED FOR:  
2700AR < P/N 21807 > 2000 PSI  
3200, 4000 < P/N 21707 > 1800 PSI  
3612 < P/N 24388 > 2300 PSI

**MH\*01459-06.50**

USED FOR:  
3200-20, 4000X-20 < P/N 21947 > 1800 PSI

**MH\*01459-08.00**

USED FOR:  
4000X-20 <P/N 23867> 1800 PSI  
(W/BEST METAL CYL.)  
3612X 9-15 <23867> 2300 PSI

**FILTER**  
MH\*01134

**ADJUSTABLE RELIEF VALVE**

**RESERVOIR O-RING**  
MH\*02352

**BREATHER CAP**  
MH\*01143

DRAWING NO.  
**50624-H**

**PUMP ASSY 2700,3200,4000,3612**  
MONARCH

DRWN BY: JC  
DATE: 1/31/08

Houston TX  
(713)-688-5533  
www.liftmoore.com

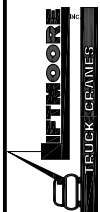

ITEM NO.	PART NUMBER	PART DESC	QTY.
1	28576	HOUSING WELDMENT 2010	1
2	28621	BASE WELDMENT 2010/3612R	1
3	27037	BEARING, CUP 2700	2
4	27038	BEARING, CONE 2700	2
5	30665	SHIELD, DUST 2700	1
6	30642	WORMGEAR 2700R/3200R	1
7	30812	SCREW, HHC 0.37-16 X 1.25 GR8	3
8	33436	WASHER, LOCK 0.37 GR5 PLT.I.T.	3
9	32911	PIN, DOWEL 0.37 DIA X 1.25 LG	3
10	19872	BEARING HOLDER MOTOR/WORM 3.2K	1
11	33107	SCREW, SET 0.37-24 X 1.50	4
12	19871	BEARING HOLDER ADJUST 3.2 ASSY	1
13	33001	MOTOR ASSEMBLY 3200 ROTATOR	1
14	33545	SCREW, SOC HD 0.50-13 X 1.50	2
15	30983	WASHER, LOCK 0.50 HICOLLAR GR5	2
16	23389	PLATE, SERIAL NO. MACHINING	1
17	22406	SCREW, DRIVE	2
18	25901	SCREW, SOC HD 0.50-13 X 10.00	2
19	30835	NUT, HEX NYLOC 0.50-13 GRADE 8	2
20	25907	ANGLE, ROTATION ADJUST	2
21	24944	SCREW, SOC HD 10-24 X 1.00	4
22	32639	WASHER, LOCK #10 GR2 PLATED	4
23	16603	SPACER, BEARING HOLDER 4000 PC	1
24	28643	WIRE, GROUND BASE PLATE	1

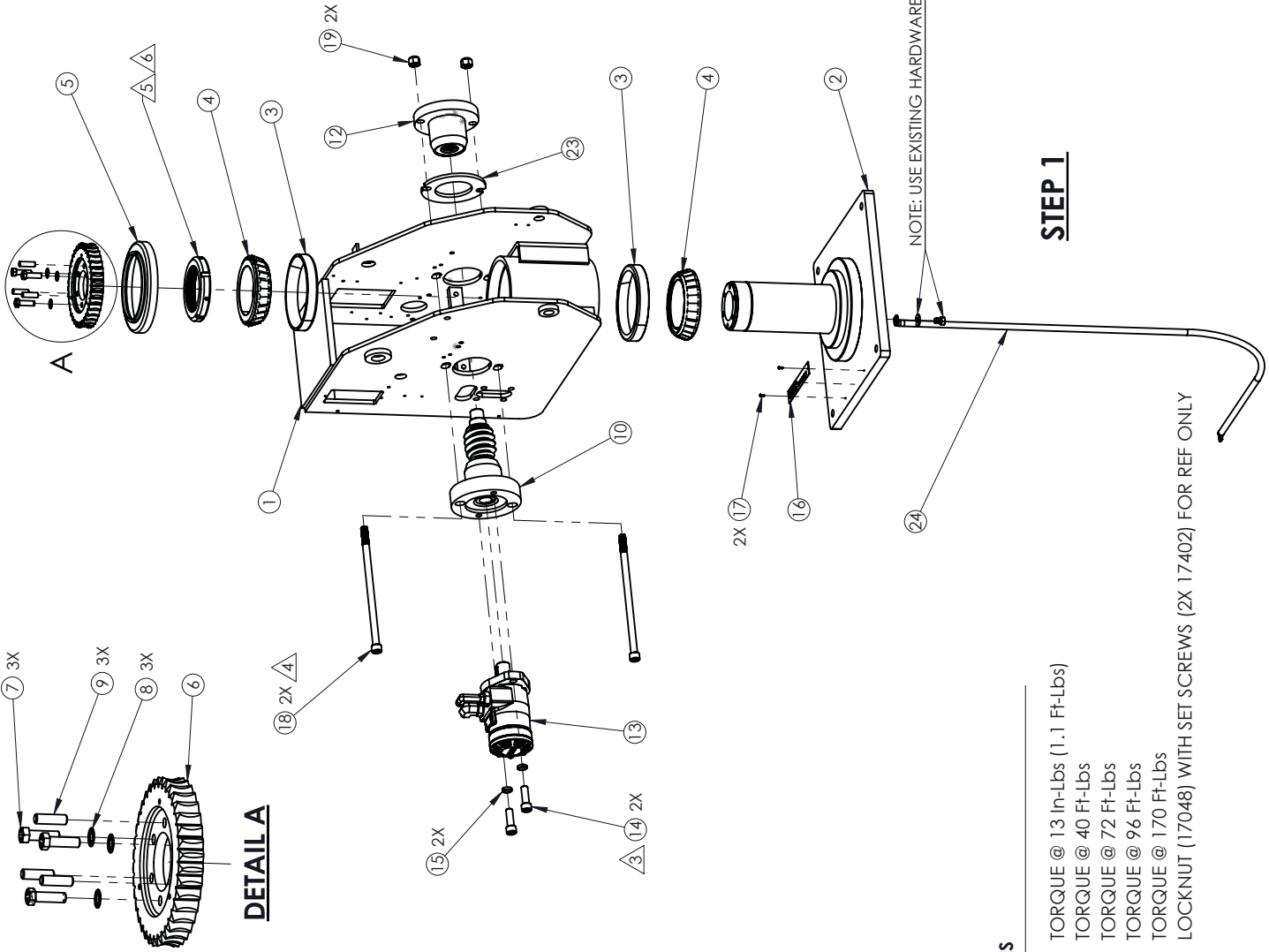

**NOTES**

- 1 TORQUE @ 13 In-Lbs (1.1 Ft-Lbs)
- 2 TORQUE @ 40 Ft-Lbs
- 3 TORQUE @ 72 Ft-Lbs
- 4 TORQUE @ 96 Ft-Lbs
- 5 TORQUE @ 170 Ft-Lbs
- 6 LOCKNUT (17048) WITH SET SCREWS (2X 17402) FOR REF ONLY

**FINAL ASSEMBLY VIEW**

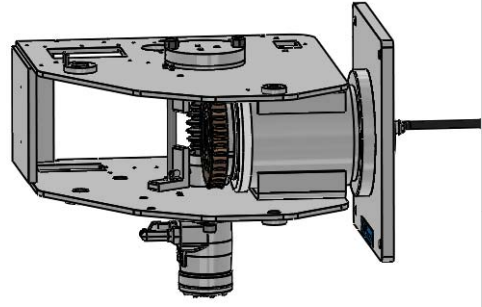

**PROPRIETARY AND CONFIDENTIAL**  
 INFORMATION CONTAINED IN THIS DOCUMENT IS THE SOLE PROPERTY OF LIFTMOORE INC.  
 REPRODUCTION IN ANY MANNER WITHOUT THE WRITTEN PERMISSION OF LIFTMOORE INC. IS PROHIBITED.

MACH. PART TO BE A MINIMUM 250 RMS UNLESS SPECIFIED  
 DEFAULT TOLERANCES UNLESS SPECIFIED:  
 XX ± .05  
 XX ± .030  
 XX ± .100  
 XX ± .116  
 XX ± .5

CHECKED: NA 12/04/2018  
 MTRL: SHEET 1 - 2  
 ENG APPR: JXE 12/04/2018

DRAWN: NA 02/08/19 DWG. NO. 28626  
 REV: D

**LIFTMOORE INC.**  
 BASE-HOUSING ASSY 2010

WEIGHT: 206.73 Lbs

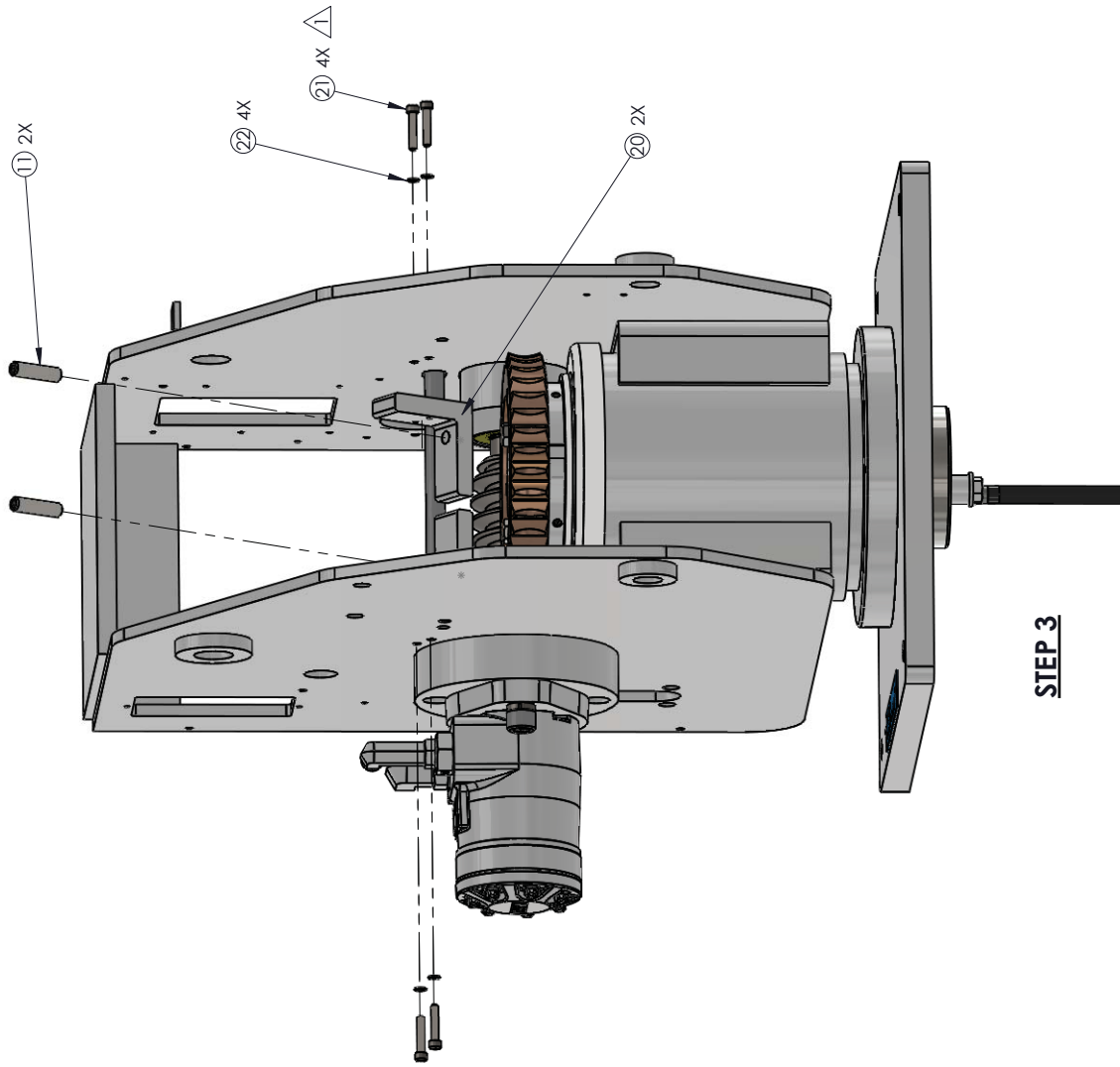

STEP 3

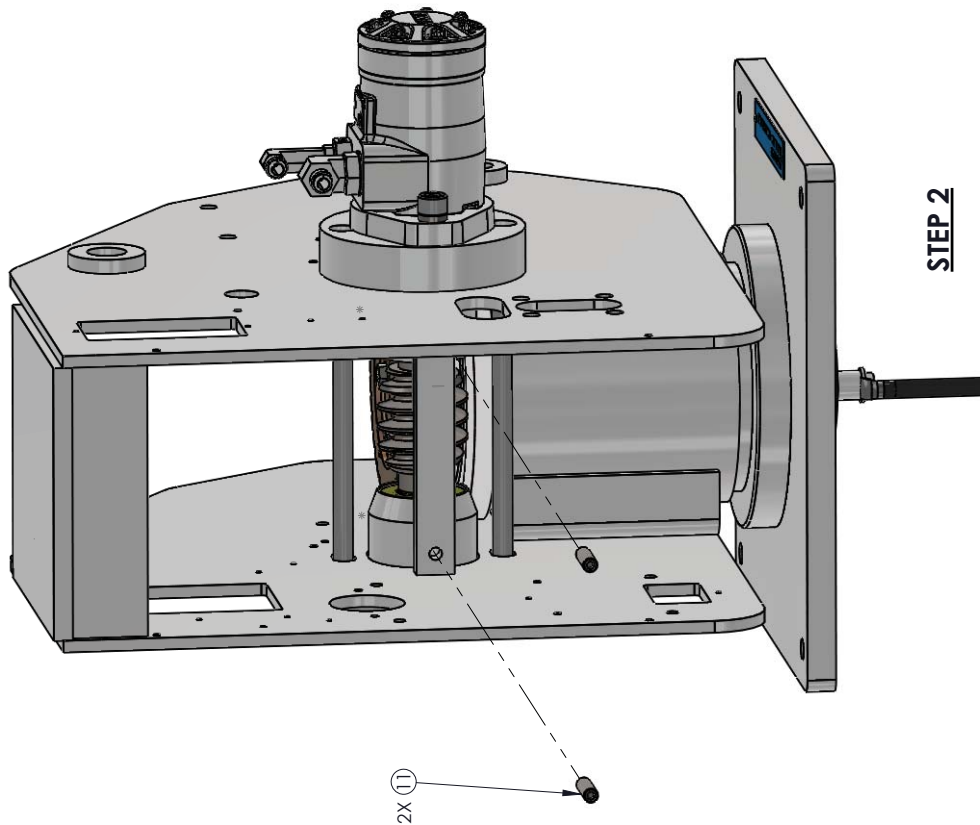

STEP 2

PROPRIETARY AND CONFIDENTIAL INFORMATION CONTAINED IN THIS DRAWING IS THE SOLE PROPERTY OF LIFTMOORE INC. REPRODUCTION IN WHOLE OR IN PART WITHOUT THE WRITTEN PERMISSION OF LIFTMOORE INC. IS PROHIBITED.

MACH. PART TO BE A MINIMUM 250 RMS UNLESS SPECIFIED OTHERWISE.  
 DEFAULT TOLERANCES UNLESS SPECIFIED:  
 .XX ± .05  
 .XX ± .030  
 .X ± .100  
 .XX ± .1/16  
 .XX ± .5°

CHECKED: NA 12/04/2018  
 ENG APPR: JXE 12/04/2018

DRAWN: NA 02/08/19 DWG. NO. 28626  
 MTRL: SHEET 2 - 2  
 WEIGHT: 206.73 LBS

REV D

LIFTMOORE INC.  
 BASE-HOUSING ASSY 2010



BY: JC  
DATE: 01/25/08

ROTATION COMPONENTS  
ISOMETRIC DWG

DOCUMENT NO.

50706-A

**TO ADJUST BACKLASH BETWEEN GEARS:**

LOOSEN MOUNTING BOLTS

MAKE SMALL ADJUSTMENTS TO THE BACKLASH ADJUSTMENT SCREWS, NO MORE THAN A 1/4 TURN. ALTERNATE BETWEEN SCREWS SO THAT ALIGNMENT IS MAINTAINED.

SOME PLAY **MUST** BE LEFT BETWEEN THE GEARS OR THE CRANE WILL NOT OPERATE PROPERLY AND EXCESSIVE WEAR AND/OR DAMAGE WILL OCCUR. INITIAL SETTING IS SUCH THAT THE RETRACTED BOOM TIP MOTION IS LESS THAN 1 INCH.

WHEN FINISHED, TORQUE THE MOUNTING BOLTS TO 40 FT-LBS

**TO ADJUST PLAY IN WORM MOUNTING:**

TIGHTEN THE 3 SET SCREWS IN THE BEARING HOLDER THEN BACK THEM OUT 1 TURN

SCREW THEM BACK IN JUST UNTIL THEY ARE SNUG. OVER TIGHTENING WILL PUT THE WORM AND MOTOR IN A BIND AND IT WILL NOT FUNCTION PROPERLY.

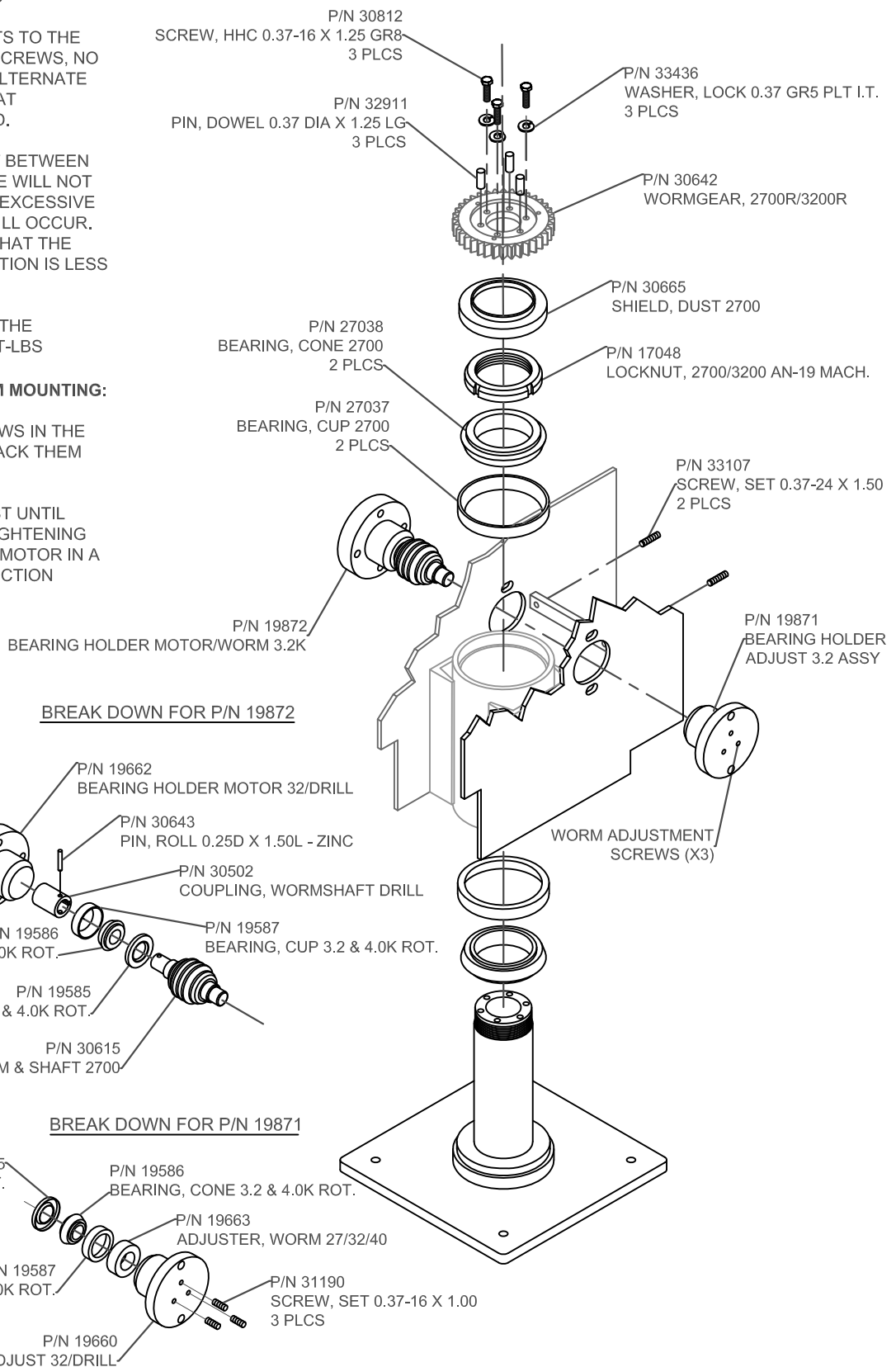





BY: KSP  
DATE: 4/24/09

**ELECTRIC SWIVEL ASSY 3200REE**  
WITH E-STOP AND HORN

DOCUMENT NO.

50754-0

DRAWING SHOWS PARTS  
BREAK DOWN OF ELECTRIC  
SWIVEL ASSEMBLY P/N 33002 &  
MOUNTING HARDWARE.

PART NUMBERS MARKED WITH  
" \* " ARE NOT PART OF THE  
ASSEMBLY. IF ORDERING  
ENTIRE SWIVEL ASSEMBLY  
THESE PARTS MUST BE  
ORDERED SEPERATELY.

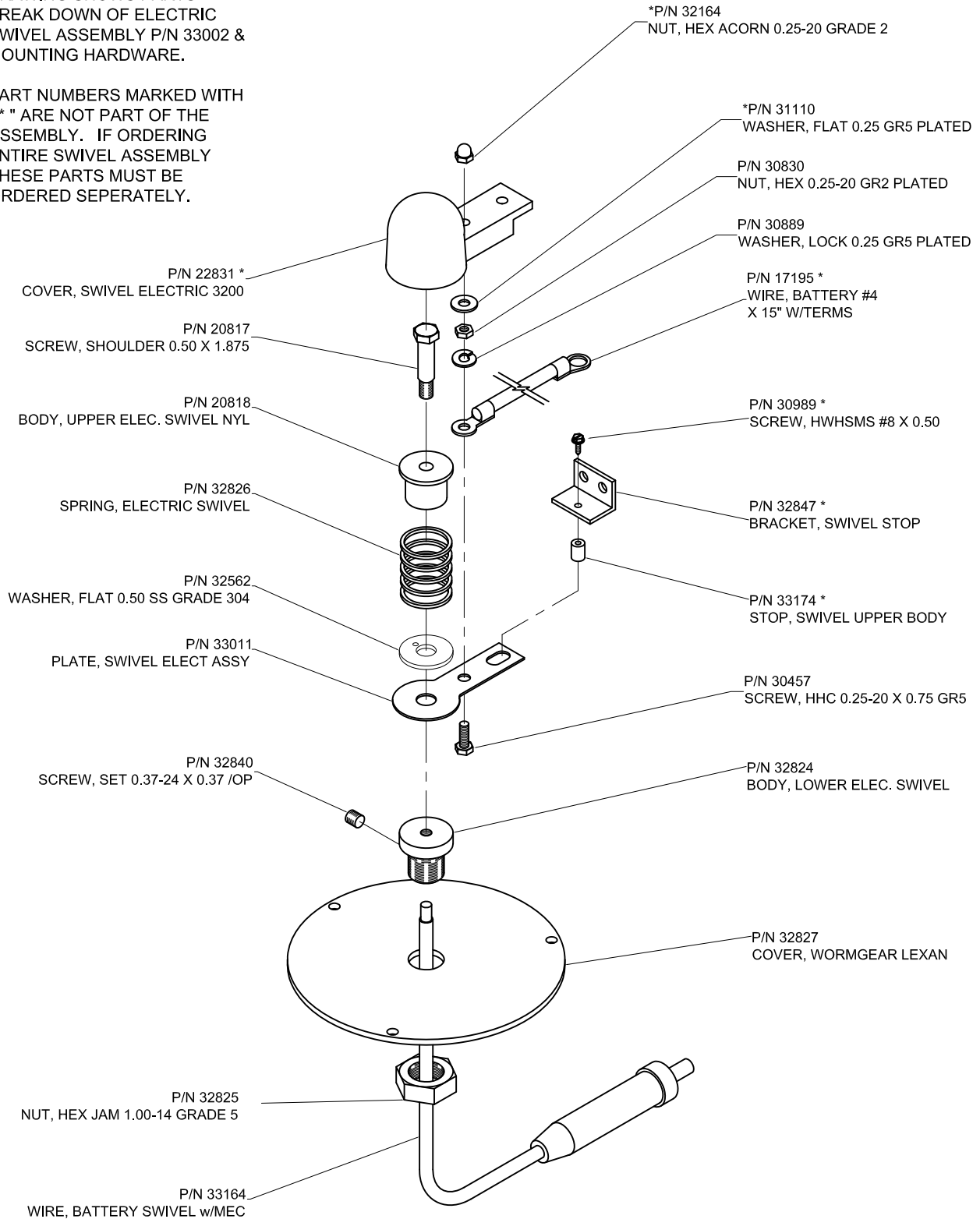

ITEM NO.	Part Number	PART DESC	QTY.
1	22937	BOOM, INNER ASSY 3200REE-15	1
2	28567	BOOM, OUTER 2010REE WELD W/ATB	1
3	33514	PIN, TEARDROP 1.00 X 5.625	1
4	33949	PAD, NYLATRON 0.26 X 4 X 3.62	1
5	33951	PAD, NYLATRON 0.25 X 3.87 X 2	3
6	30473	WASHER, LOCK 0.37 GR5 PLATED	1
7	30809	SCREW, HHC 0.25-20 X 0.50 GR5	9
8	15789	CLAMP, HALVES 2 STL HYD TUBE	2
9	31110	WASHER, FLAT 0.25 GR5 PLATED	1
10	31189	SCREW, HHC 0.25-20 X 1.25 GR5	1
11	70027	SCREW, HHC M12 X 1.75-45MM GR8	4
12	30983	WASHER, LOCK 0.50 HICOLLAR GR5	4
13	33367	SCREW, EYE 0.25-20 W/ NUT	2
14	23872	WINCH, ELEC 12VDC 4000	1
15	33169	SCREW, HHC 0.37-16 X 0.62 GR8	1
16	30936	ZERK, 0.25-28 STRAIGHT	1
17	33920	PLUG, BOOM HOLE 1.375 PLASTIC	2
18	30889	WASHER, LOCK 0.25 GR5 PLATED	11
19	32485	BUSHING, BOOM PIVOT 3200/4000	2

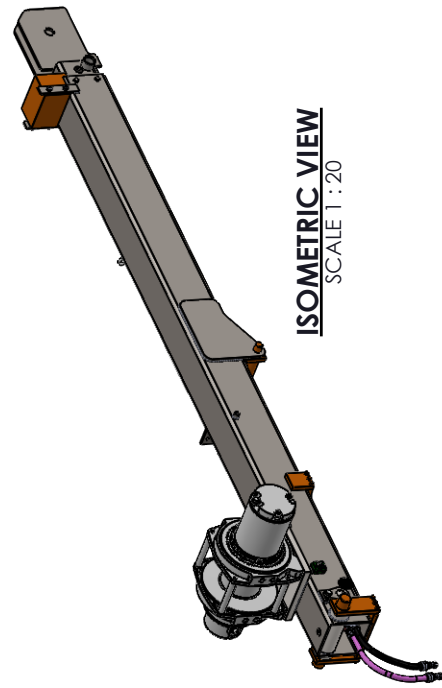
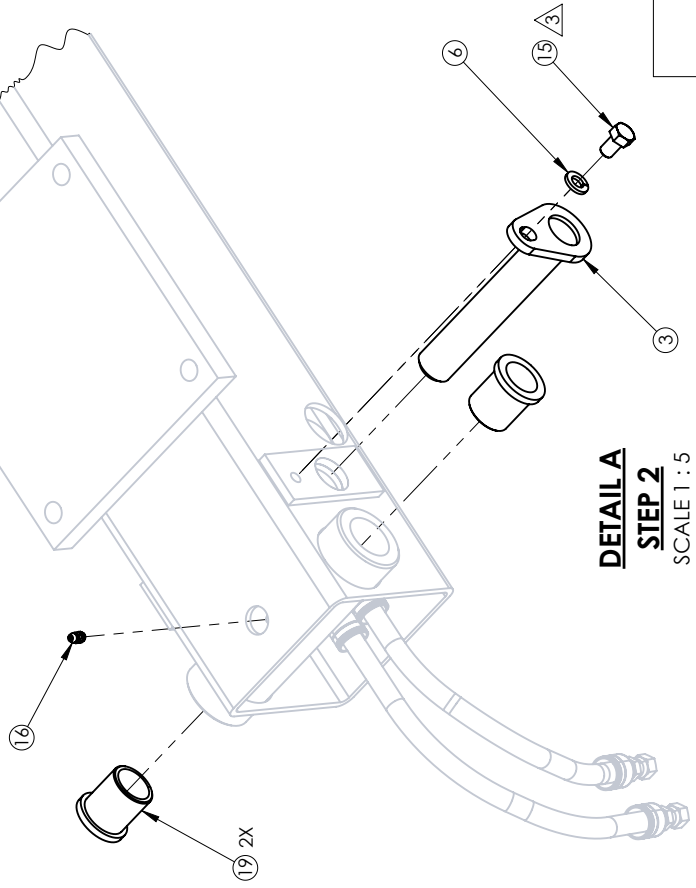
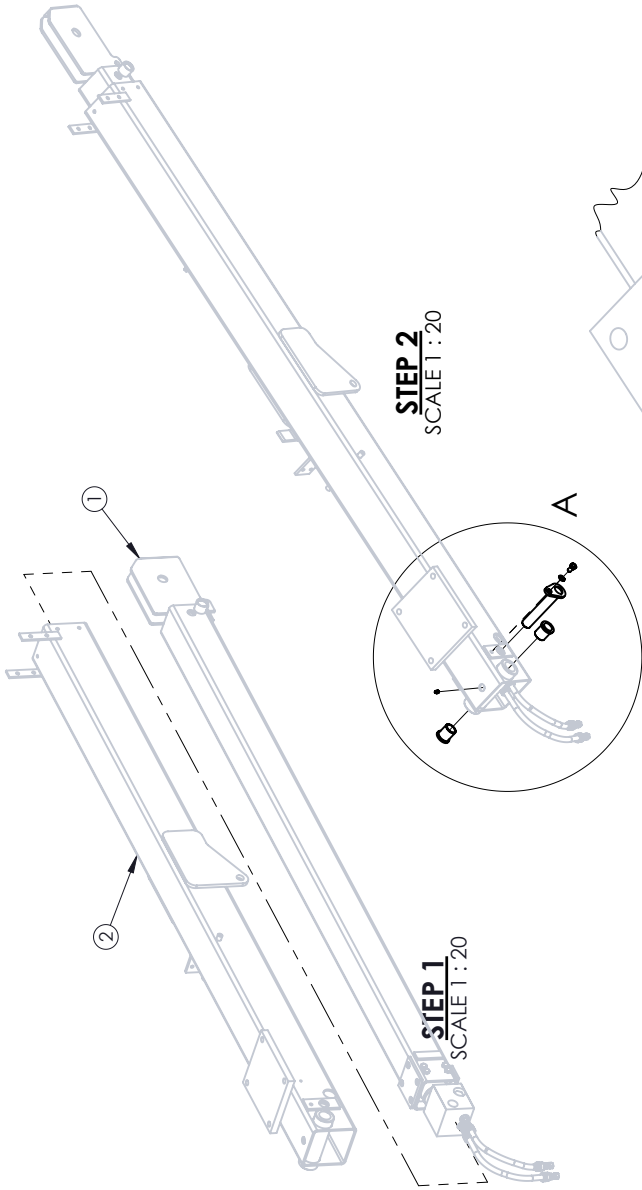

**LIFTMOORE INC.**

BOOM ASSEMBLY 2010REE-15 ATB

**NOTE**  
MACH. PART TO BE A MINIMUM 250 RMS UNLESS SPECIFIED

PROPRIETARY AND CONFIDENTIAL  
THE INFORMATION CONTAINED IN THIS DRAWING IS THE SOLE PROPERTY OF LIFTMOORE INC. ANY REPRODUCTION OR TRANSMISSION OF THIS DRAWING WITHOUT THE WRITTEN PERMISSION OF LIFTMOORE INC. IS PROHIBITED.

DEFAULT TOLERANCES  
.XXX ± .005  
.XX ± .003  
.X ± .001  
FRAC. ± 1/16  
XX° ± .5°

DRAWN NA 07/12/2018 DWG. NO. 28568  
CHECKED AAT 07/12/2018  
ENG APPR RZK 07/12/2018

MATERIAL: WEIGHT: 340.90 Lbs

REV B

SHEET 1 - 2

- NOTE**
- 1 TORQUE @ 1.2 Ft-Lbs
  - 2 TORQUE @ 37 Ft-Lbs
  - 3 TORQUE @ 41 Ft-Lbs
  - 4 HAND TIGHT

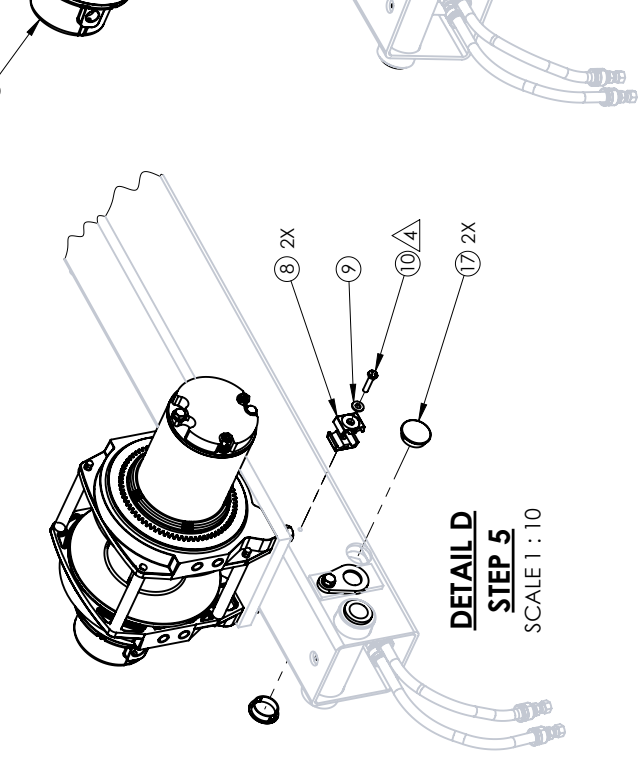
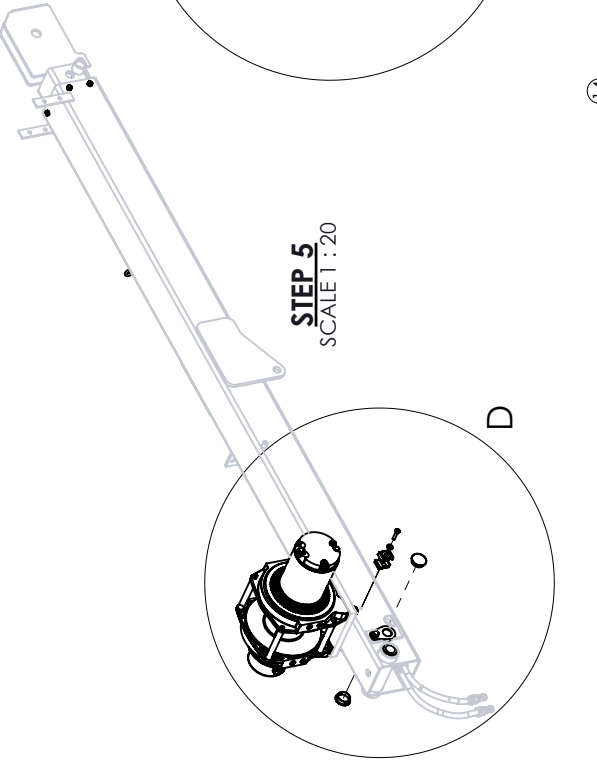
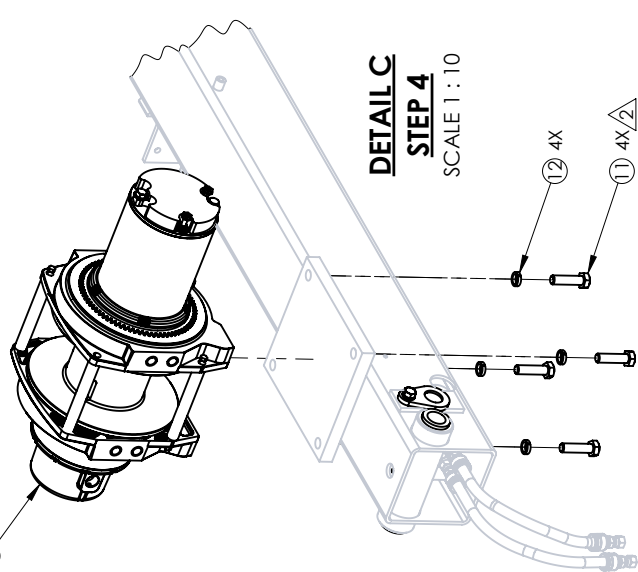
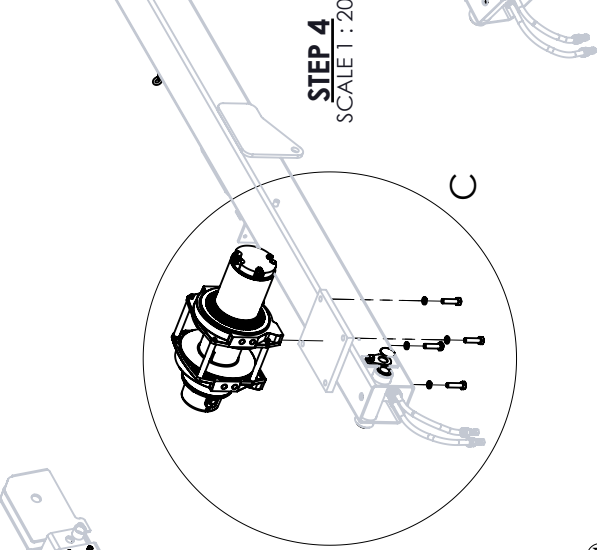
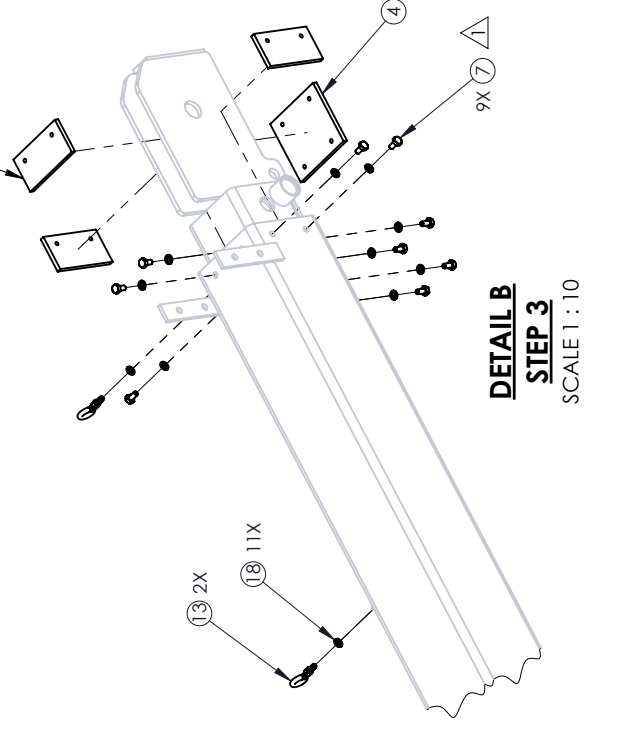
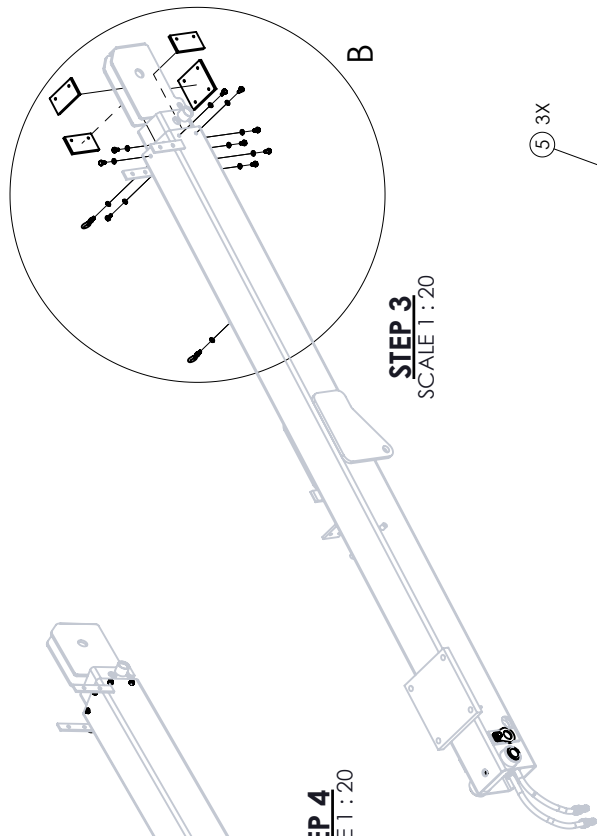

**LIFTMOORE INC.**

BOOM ASSEMBLY 2010REE-15 AT1B

MACH. PART TO BE A MINIMUM  
250 RMS UNLESS SPECIFIED

DEFAULT TOLERANCES  
UNLESS OTHERWISE SPECIFIED:  
.XXX ± .005  
.XX ± .000  
.X ± .000  
FRACTION ± 1/16  
XX° ± .5°

PROPRIETARY AND  
CONFIDENTIAL  
THE INFORMATION  
CONTAINED IN THIS DRAWING  
IS THE SOLE PROPERTY OF  
LIFTMOORE INC. ANY  
REPRODUCTION OR  
TRANSMISSION OF THIS  
DRAWING WITHOUT THE  
WRITTEN PERMISSION OF  
LIFTMOORE INC. IS PROHIBITED.

DRAWN	NA	07/12/2018	DWG. NO.	28568	REV	B
CHECKED	AAT	07/12/2018	ENG APPR.	RZK	07/12/2018	MATERIAL:
				WEIGHT:	340.90 Lbs	SHEET 2 - 2

ITEM NO.	PART NUMBER	PART DESC	QTY.
1	33017	BOOM, INNER 1ST 3200REE-15 WLD	1
2	22936	BOOM, INNER 2ND 3200REE-15 WLD	1
3	34115	CYLINDER ASSY 3200 EXT(MOD 1)	1
4	33169	SCREW, HHC 0.37-16 X 0.62 GR8	8
5	33950	PAD, NYLON 0.26 X 4 X 3.62 CSK	1
6	33952	PAD, NYLON 0.25 X 3.87 X 2 CSK	1
7	33614	SCREW, SOC FH 0.25-20 X 0.50	6

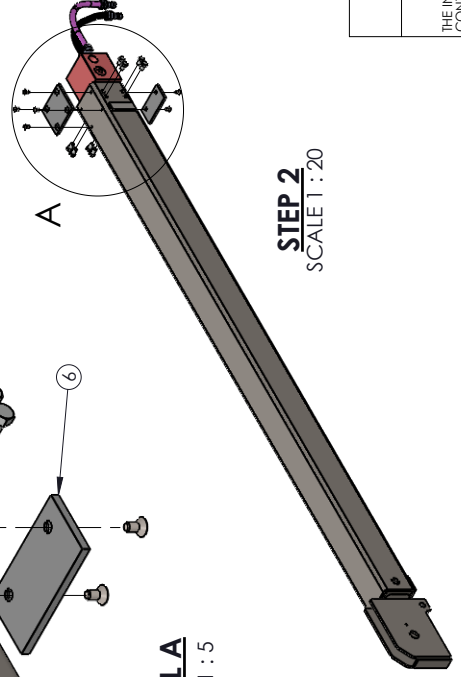
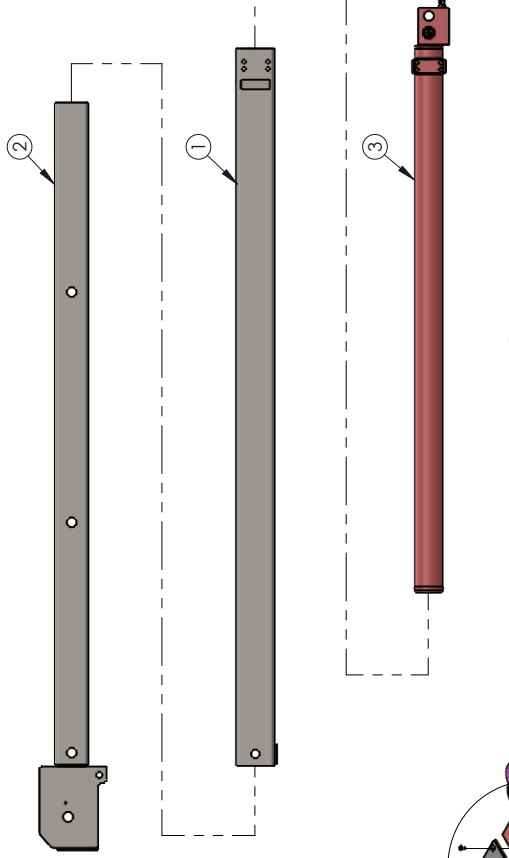
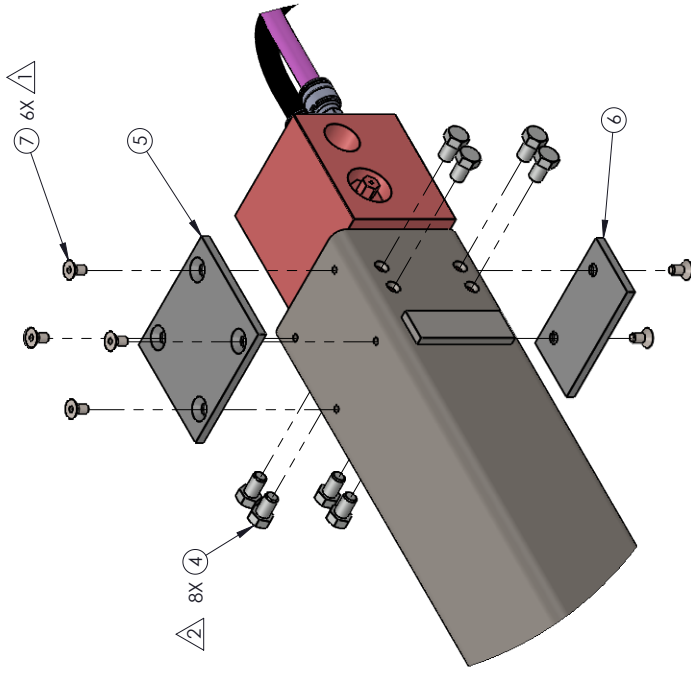
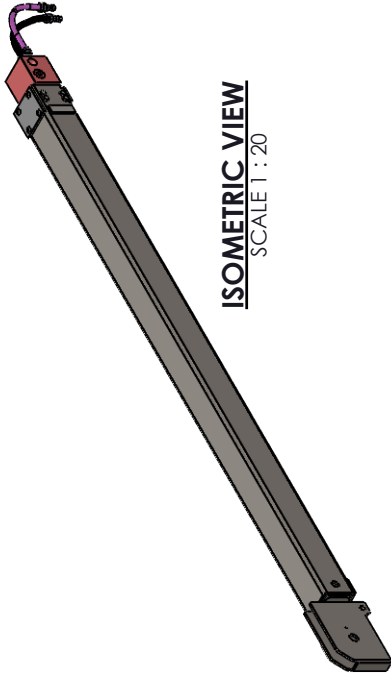

**LIFTMOORE INC.**

BOOM, INNER ASSY 3200REE-15

**PROPRIETARY AND CONFIDENTIAL**  
THE INFORMATION CONTAINED IN THIS DRAWING IS THE SOLE PROPERTY OF LIFTMOORE INC. ANY REPRODUCTION OR TRANSMISSION OF THIS DRAWING WITHOUT THE WRITTEN PERMISSION OF LIFTMOORE INC. IS PROHIBITED.

MACH. PART TO BE A MINIMUM 250 RMS UNLESS SPECIFIED

DEFAULT TOLERANCES UNLESS OTHERWISE SPECIFIED:  
 .XXX ± .005  
 .XX ± .002  
 .X ± .001  
 FRACTION ± 1/16  
 ANGLES ± .5°

DRAWN	NA	07/02/2018	DWG. NO.	
CHECKED	AAT	07/02/2018		
ENG APPR	RZK	07/02/2018		
MATERIAL:				REV
				B
				22937
				WEIGHT: 178.41 Lbs
				SHEET 1 - 1

- NOTES**
- 1 TORQUE @ 12.5 FT-Lbs
  - 2 TORQUE @ 41 FT-Lbs, ADD VIBRA-TITE TO THREADS

**WINCH DC2000 12VDC P/N 23872**

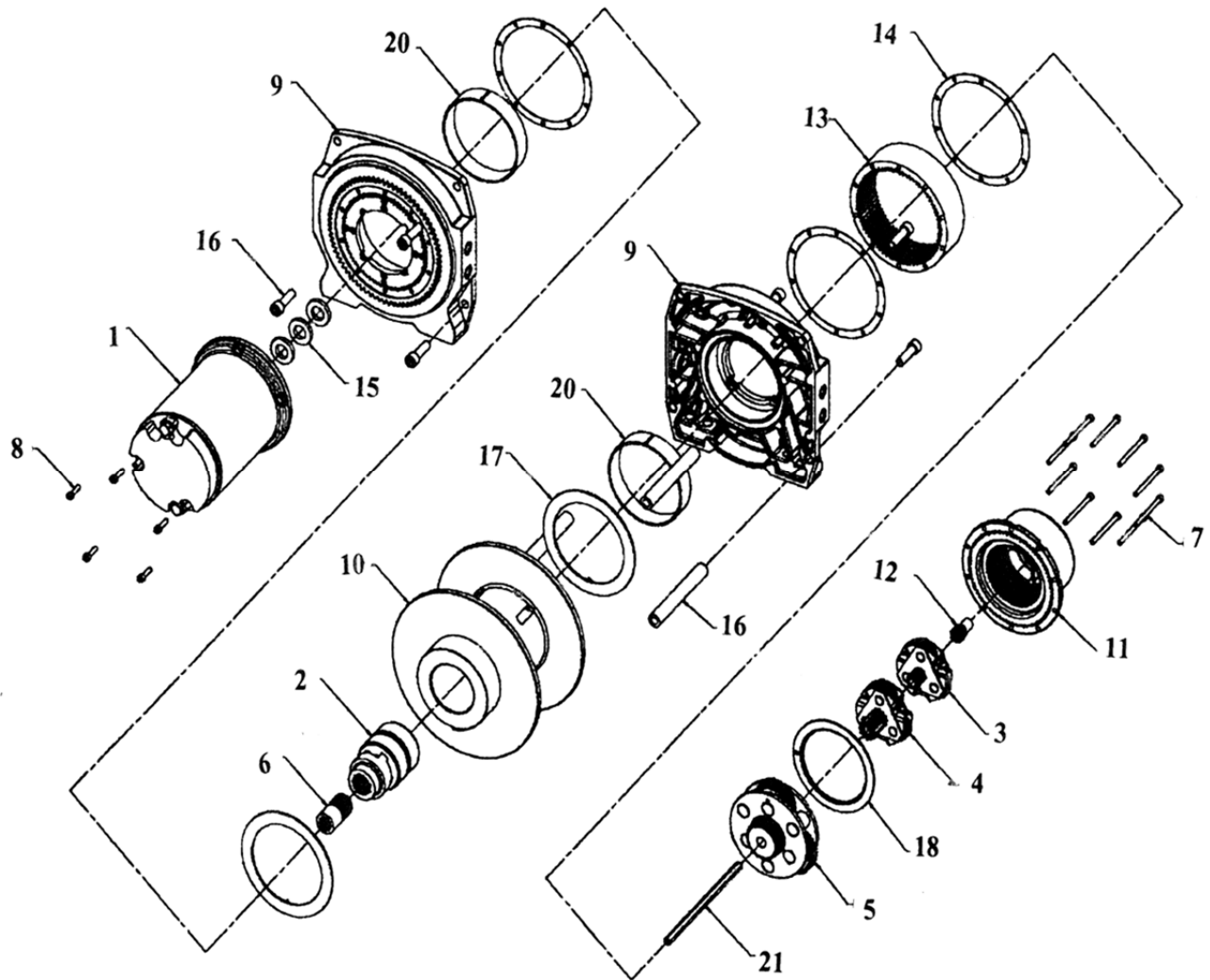

## SERVICE PARTS LIST: DC2000LF HOIST-12V P/N 23872

ITEM REFERENCE		ITEM / KIT No.
1	MOTOR SPLINED 12V DC	WI*84211
2	BRAKE ASSEMBLY DC2000	WI*63550
3	CARRIER ASSY, STAGE 1	WI*28430
4	CARRIER ASSY, STAGE 2	WI*28433
5	CARRIER ASSY, STAGE 3	WI*28115
6	COUPLER, MOTOR/BRAKE	WI*32149
7	CPSCR, 10-24 X 2-1/4-HEX SOCKET HEAD-PI	WI*13850
8	CPSCR, SOC, 10-24 X 3/4, GR9 (KB)	WI*5553
9	(MTO) S/P DRUM SUPPORT, GEAR END	WI*85575
10	DRUM, (KB) 2000-MF, 4.25 DIA	WI*31618
11	SVC KIT END HOUSING SUBASSY, CLUTCH PLUG	WI*85583
12	GEAR, SUN, 12 TOOTH, STAGE 1	WI*13874
13	RING GEAR, ARG, 75 TOOTH	WI*25308
14	HOUSING, GASKET	WI*13848
15	SPACER, MOTOR	WI*15271
16	SVC KIT TIE ROD, ALUMN, .625 X 4.92	WI*85579
17	WASHER, TRUST, NYLATRON, CIM	WI*30277
18	WASHER, TRUST, NYLON, MIDRANGE	WI*13826
19	PARTS PACK, DC2000 HOIST	WI*60049
20	BUSHING DRUM NYLATRON	WI*30274
21	SHAFT-DRIVE-HEX 5/16 X 6.85	WI*84346



**NOTE: A**

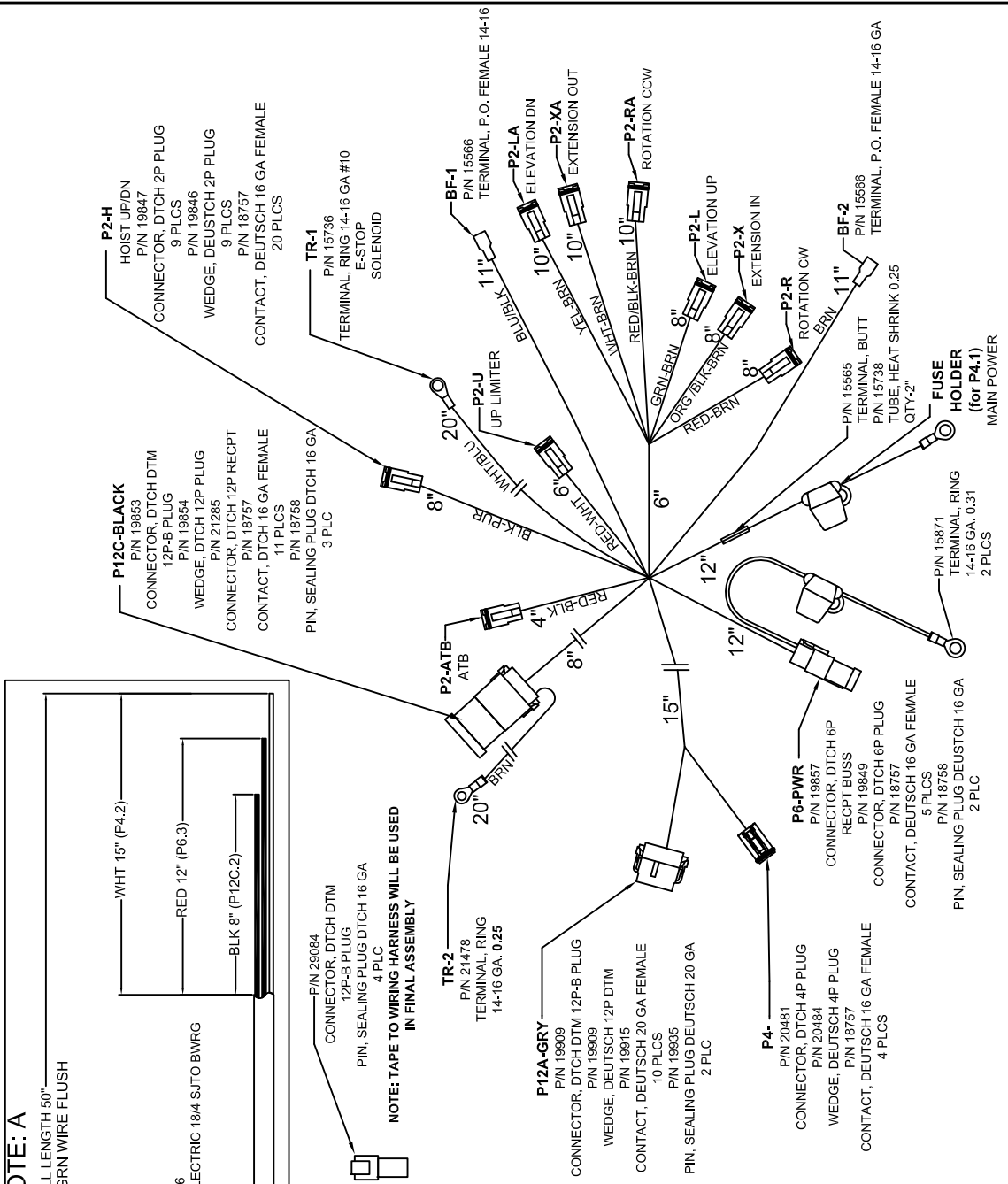
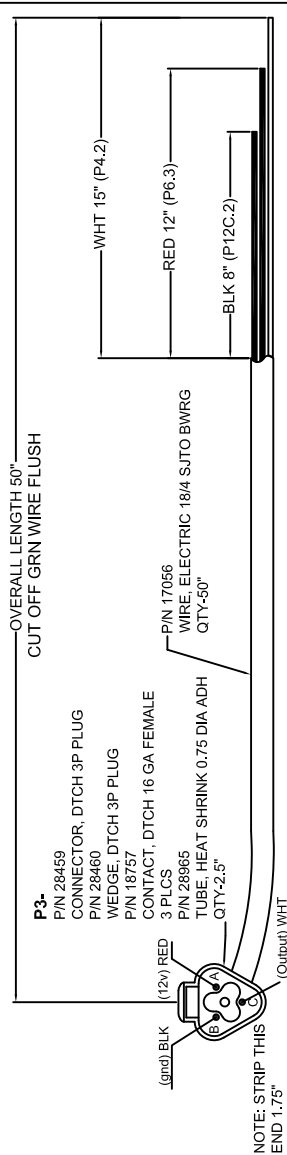

**NOTE: TAPE TO WIRING HARNESS WILL BE USED IN FINAL ASSEMBLY**

CIRCUIT NUMBER AND DESCRIPTION		
COLOR	LENGTH	CONNECTORS
RED	29"	P12A.1
RED/BLK	31"	P2-R.1
WHT	31"	P2-RA.1
ORG/BLK	29"	P2-XA.1
GRN	29"	P2-L.1
YEL	31"	P2-LA.1
PURP	23"	P2-H.2
BLK	23"	P2-A.8
WHT/BLU	35"	P12A.10
WHT	21"	P12A.12
RED	27"	P4.1
SEE NOTE A	P3.C	
BLK	19"	P4.3
BLU/BLK	26"	P4.4
YEL	N/A	P6.1
SEE NOTE A	P6.3	
RED	18"	P6.4
RED	16"	P6.5
N/A	N/A	P6.6
SEE NOTE A	P12C.2	
BRN	20"	P12C.1
BRN	24"	P12C.3
BRN	22"	P2-RA.2
BRN	24"	P2-R.2
BRN	22"	P2-XA.2
BRN	22"	P2-L.2
BRN	22"	P2-L.2
BRN	24"	P12C.7
BRN	24"	P12C.8
BRN	18"	P12C.9
		TR-2
		P2-RA.2
		P2-R.2
		P2-XA.2
		P2-L.2
		P2-L.2
		P2-X.2
		P2-LA.2
		BF-2

FUNCTION	
ROTATION CW	
ROTATION CCW	
EXTENSION OUT	
EXTEND IN	
BOOM UP OUTPUT	
BOOM DOWN OUTPUT	
HOIST UP	
HOIST DN	
E-STOP SOLENOID	
UP LIMIT SW: INPUT	
RECEIVER POWER 12V	
TRANSDUCER SIGNAL	
ATB SIGNAL INPUT	
HORN OUTPUT 12V	
MAIN POWER	
TRANSDUCER PWR	
UP LIMIT 12V	
ATB 12V	
PLUG	
TRANSDUCER GND	
MAIN GROUND	
ROT. CCW VALVE GND	
ROT. CW VALVE GND	
EXT. OUT VALVE GND	
ELEV. UP VALVE GND	
EXT. IN VALVE GND	
ELEV. DN VALVE GND	
ELEV. DN VALVE GND	

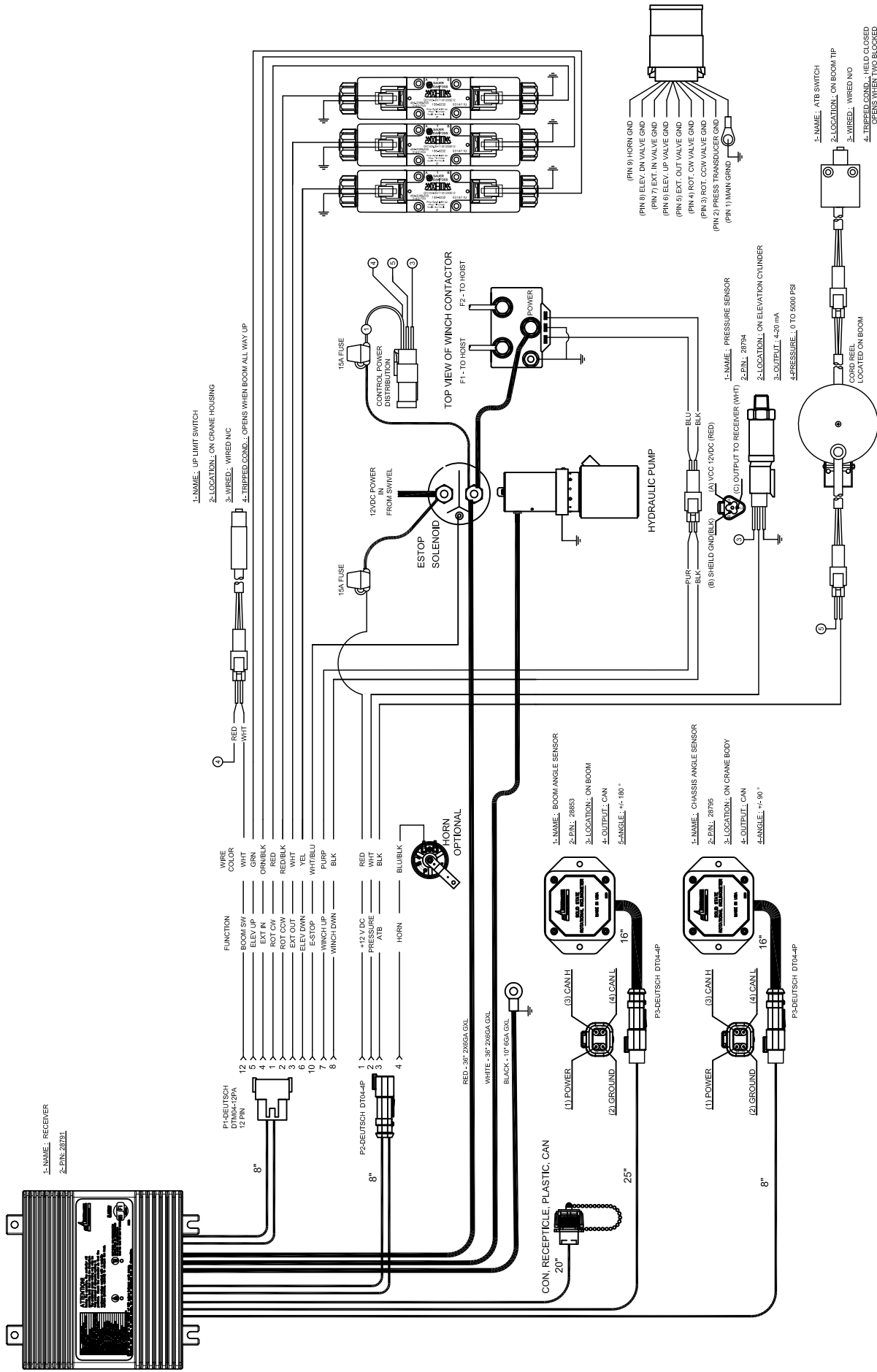

**EWH, DTCH ELEC WIFI KTG WP**

DRWN BY: JE  
DATE: 8/1/19

Houston TX  
(713)-688-5533  
www.liftmoore.com





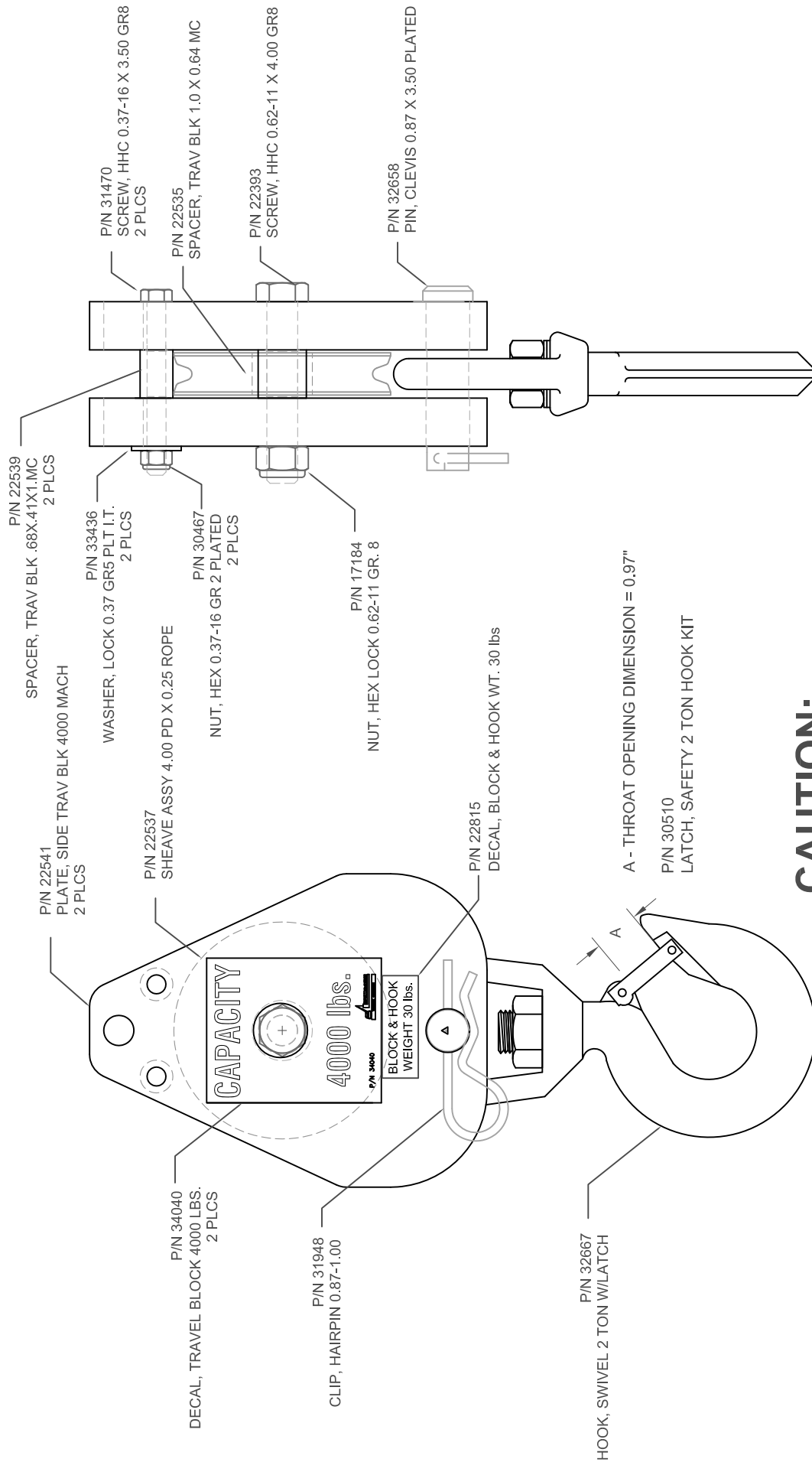

**CAUTION:**

NEVER USE A HOOK WHOSE THROAT OPENING HAS BEEN INCREASED, OR WHOSE TIP HAS BEEN BENT MORE THAN 10 DEGREES OUT OF PLANE FROM THE HOOK BODY, OR IS IN ANY WAY DISTORTED OR BENT.

DRAWING NO.  
**22532-D**

**BLOCK, TRAV ASSY 4.0K lbs/4.0D**  
4.00PD X 0.25 ROPE; 4K LBS

DRWN BY: JC  
DATE: 6/23/08

Houston TX  
(713)-688-5533  
www.iftmoore.com



THIS DRAWING INTENTIONALLY LEFT BLANK

FOR FUTURE ADDITIONS

OR

A PART OR FEATURE IS NOT APPLICABLE TO THIS CRANE



Houston TX  
(713)-688-5533  
[www.iftmoore.com](http://www.iftmoore.com)

DRWN BY:

DATE:

DRAWING NO.

## **LIFTMOORE LIMITED WARRANTY**

### Parts and Structural

Liftmoore, Inc. warrants each LIFTMOORE crane to be free from defects in materials and workmanship for twelve (12) months from the date of delivery to the original customer. Under the terms of this warranty the crane structural components manufactured by LIFTMOORE, Inc. are warranted for thirty-six (36) months from the date of delivery to the original customer. LIFTMOORE, Inc. will repair or replace, as its sole discretion, any equipment or part that is returned f.o.b. to LIFTMOORE, Inc.'s plant at 7810 Pinemont Drive, Houston, Texas 77040, or to one of its authorized dealers, and is found by LIFTMOORE, Inc. or its authorized dealer to have been defective at the time of original delivery.

The foregoing warranty is the exclusive warranty made by LIFTMOORE, Inc. with respect to its cranes and is in lieu of all other warranties. ANY AND ALL OTHER WARRANTIES, EXPRESS OR IMPLIED, INCLUDING ANY WARRANTY OF MERCHANTABILITY OR FITNESS OF ANY CRANE FOR A PARTICULAR PURPOSE OR OPERATION, ARE HERBY EXPRESSLY DISCLAIMED.

The foregoing warranty applies only to LIFTMOORE cranes under normal use and service and does not apply in the event of damage caused by repair or alteration or damage during shipment, accident, negligence, overloading, or misuse, including operator's failure to follow any of the instructions issued with the crane.

This warranty is limited to the original purchaser and is not assignable. In order to submit a claim, the original purchaser must provide a copy of the original invoice for the crane in question within twelve (12) months following the delivery date and within 30 days from the date of repair.

The warranty applies only when the LIFTMOORE crane is used for commercial purposes and does not cover any purchase for use for personal, family or household purposes.

**LIMITATION OF LIABILITY:** LIFTMOORE, Inc.'s liability for any losses or damages resulting from any cause whatsoever, including LIFTMOORE, Inc.'s NEGLIGENCE or from a defective crane irrespective of whether such defects are discoverable or latent, shall in no event exceed the purchase price of the crane to which losses or damages are claimed, or at the election of LIFTMOORE, Inc., the repair or replacement of the defective crane.

In no event shall LIFTMOORE, Inc. be liable for any special, incidental, or consequential damages, including commercial losses or costs of any kind sustained by purchaser or any other person or for any damages for which purchaser may be liable to other persons by reason of any defect in any LIFTMOORE crane or any part thereof.

LIFTMOORE, Inc. reserves the right to make changes in design or construction of its cranes at any time without obligating itself to make such changes on cranes previously manufactured.

No agent, employee, or representative of LIFTMOORE, Inc. has authority to amend or modify the foregoing warranty or to bind LIFTMOORE, Inc. by any other warranty, guaranty, or assumption of liability.

In the event any provision of this warranty is for any reason held ineffective, the remaining provisions shall remain in full force and effect.

Some states do not allow limitations on how long an implied warranty lasts or the exclusion or limitation of incidental or consequential damages, so the above limitations and exclusions may not apply to you. This warranty gives you specific legal rights, and you may also have other legal rights that vary from state to state.

