

**TABLE OF CONTENTS**  
 USERS MANUAL P/N 27364  
 LA6K EX-11 PENDANT CONTROL  
 INCLINOMETER, TRANSDUCER & BAIL ATB, VOLTMETER

**SECTION I  
 GENERAL OPERATION, INSPECTION, AND MAINTENANCE**

CRANE SAFETY RULES .....	F1122-B .....	1-1
INTRODUCTION .....	F1111-D .....	1-3
OPERATING RESTRICTIONS .....	F1112-E .....	1-4
OPERATING PRACTICES .....	F1112-E .....	1-4
INSPECTION AND MAINTENANCE .....	F1113-D .....	1-7
MONTHLY INSPECTION REPORT .....	F1123-B .....	1-9

**SECTION II  
 CRANE SYSTEMS AND TROUBLESHOOTING**

KTFM CONTROL SYSTEM(OPTIONAL) .....	F1327-C .....	2-1
SAFETY SYSTEM.....	F1923-0 .....	2-2
ELECTRIC HOIST .....	F1239-0 .....	2-3
HYDRAULIC SYSTEM FOR ELECTRIC CRANE .....	F1145-C .....	2-4
TROUBLESHOOTING KHFM CONTROL SYSTEM.....	F1328-A .....	2-6
TROUBLESHOOTING ELECTRIC HOIST .....	F1243-A .....	2-7
TROUBLESHOOTING HYRAULIC PUMP .....	F1255-B .....	2-9
LIMITING SYSTEM OPERATIONS .....	F2202-0 .....	2-10
LIMITING SYSTEM CONNECTION INFORMATION .....	F2203-0 .....	2-12
LIMITING SYSTEM ROUTINE MAINTENANCE.....	F2204-0 .....	2-13
LIMITING SYSTEM TROUBLESHOOTING CHART.....	F2205-0 .....	2-14
LIMITING SYSTEM ERROR CODE CHART .....	F2206-0 .....	2-16
LIMITING SYSTEM PARTS LIST .....	F2207-0 .....	2-17
LIMITING SYSTEM SPECIFICATIONS .....	F2208-0 .....	2-18
LIMITING SYSTEM ANGLE SENSOR SETUP .....	F2209-0 .....	2-19
LIMITING WIRING DIAGRAM .....	F2210-0 .....	2-21

**SECTION III  
 CRANE SPECIFICATIONS**

LIFTING CAPACITIES .....	F1830-0 .....	3-1
POWER FUNCTIONS AND SPEEDS .....	F1830-0 .....	3-1
BOLT AND LUBRICATION SPECS.....	F1830-0 .....	3-2

**SECTION IV  
 PARTS**

BOX PARTS LIST.....	F2312-0 .....	4-1
CRANE ASSEMBLY .....	DWG.27362-A .....	4-2
PENDANT CONTROL.....	DWG.25181-0 .....	4-3
KTFM MEGA WIRELESS CONTROLS (OPTIONAL).....	DWG.23821-C .....	4-4
RELAY BOX ASSEMBLY .....	DWG.25863-0 .....	4-5
TRAVEL BLOCK ASSEMBLY .....	DWG.23697-A .....	4-6
BOOM-BODY ASSEMBLY .....	DWG.27361-A .....	4-7
ELEVATION CYLINDER .....	DWG.24842-0 .....	4-8



**TABLE OF CONTENTS**  
 USERS MANUAL P/N 27364  
 LA6K EX-11 PENDANT CONTROL  
 INCLINOMETER, TRANSDUCER & BAIL ATB, VOLTMETER

BODY ASSEMBLY .....	DWG.27360-A .....	4-9
MANIFOLD ASSEMBLY .....	DWG.27501-0 .....	4-10
HYDRAULIC PUMP .....	DWG.24839-A .....	4-11
BASE-HOUSING ASSEMBLY .....	DWG.27359-0 .....	4-12
ELECTRIC SWIVEL .....	DWG.19438-B .....	4-13
BOOM ASSEMBLY – 11FT .....	DWG.26897-0 .....	4-14
BOOM INNER ASSEMBLY – 11FT .....	DWG.26896-0 .....	4-15
WINCH.....	DWG.22289-B .....	4-16
WINCH PARTS LIST .....	DWG.22289-B .....	4-17
ELECTRIC WIRING HARNESS .....	DWG.25864-A .....	4-18
ELECTRIC SCHEMATIC.....	DWG.50871-A .....	4-19
ATB ASSEMBLY .....	DWG.58416-0 .....	4-20
ROTATOR ASSEMBLY .....	DWG.26490-0 .....	4-21
INCLINOMETER DIAGRAM .....	DWG.24455-0 .....	4-22
TRANSDUCER DIAGRAM .....	DWG.24456-A .....	4-23
DECAL DIAGRAM .....	DWG.58415-A .....	4-24
WARRANTY.....	F1442-A	



## CRANE SAFETY RULES

### CAUTION!

1. READ AND UNDERSTAND OPERATOR'S MANUAL.
2. INSPECT VEHICLE AND CRANE, INCLUDING ITS OPERATION BEFORE DAILY USE.
3. USE THIS EQUIPMENT ONLY ON SOLID LEVEL GROUND WITH OUTRIGGERS OR JACKSTANDS PROPERLY SET.
4. BEFORE OPERATING THE CRANE REFER TO MAXIMUM LOAD CHART ON CRANE FOR OPERATING LOAD LIMITS.
5. BE SURE LOAD BEING LIFTED IS WITHIN SAFE WINCH CAPACITY AS WELL AS SAFE CRANE CAPACITY. MULTI-PART LINE OPERATION IS REQUIRED WHEN SINGLE LINE LOAD CAPACITY OF WINCH IS EXCEEDED.
6. DO NOT OPERATE, WALK, OR STAND UNDER THE BOOM OR ANY SUSPENDED LOAD.
7. ALWAYS PAY OUT LOAD LINE BEFORE EXTENDING BOOM. WIRE ROPE DAMAGE AND / OR BREAKAGE MAY OCCUR.
8. BOOM MUST BE IN ITS REST BEFORE MOVING VEHICLE.
9. BOOM TIP MUST BE DIRECTLY OVER THE LOAD BEFORE ANY LIFTING IS STARTED. DO NOT DRAG LOADS WITH THIS CRANE.
10. MAINTAIN THIS CRANE AS REQUIRED IN THE OWNER'S MANUAL.
11. DO NOT ALLOW PERSONNEL TO RIDE ON THE LOAD LINE, LOAD, OR BOOM OF THIS CRANE.
12. IT IS UNLAWFUL TO OPERATE THIS EQUIPMENT WITHIN TEN FEET OF HIGH VOLTAGE LINE



F1122-B  
05/12/08

HOUSTON, TEXAS  
FAX: (800) 824-5559 (USA & Canada)  
FAX: (713) 688-6324  
PHONE: (713) 688-5533  
[www.liftmoore.com](http://www.liftmoore.com)

THIS PAGE INTENTIONALLY LEFT BLANK

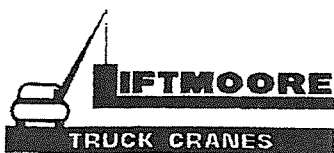

F1122-B  
05/12/08

HOUSTON, TEXAS  
FAX: (800) 824-5559 (USA & Canada)  
FAX: (713) 688-6324  
PHONE: (713) 688-5533  
[www.iftmoore.com](http://www.iftmoore.com)

## INTRODUCTION

This crane is a powerful machine designed to lift and move heavy loads. There are many hazards associated with these operations. Liftmoore has designed this crane to be as safe as possible but -

**IT IS THE OPERATOR'S RESPONSIBILITY TO PREVENT ACCIDENTS!**

This takes pre-planning, attention, and knowledge of basic principles and rules. Even if you have used similar cranes, reading this manual in its entirety will help prevent damage, injury, or even loss of life; benefits well worth the short amount of time it takes to read these pages.

### REGULATORY AUTHORITY

Use of this crane is governed by OSHA 29 CFR 1910.180 and may be governed by other federal, state, or local regulations.

**IT IS THE OPERATOR'S RESPONSIBILITY TO UNDERSTAND AND COMPLY WITH ALL APPLICABLE REGULATIONS GOVERNING THE OPERATION, INSPECTION, AND MAINTENANCE OF THIS CRANE.**

Personnel should be trained, tested, and certified, as recommended by OSHA and ANSI standards, before operating this crane.

### USING THIS MANUAL

This manual assumes that the crane is mounted on a typical service body type or similar truck, which is powered by the vehicle electrical or hydraulic system, and is controlled by either the standard pendant control or FM radio control sold by Liftmoore, Inc.

This manual is supplied to provide basic guidelines for the safe use, routine maintenance, and general inspections of this crane.

Laws, regulations, standards, or policies may be more restrictive than this manual. If a conflict exists for any limit or condition, the safest or most prohibitive shall be used. Under no circumstances shall the load, moment, or stability ratings be exceeded.

Pay particular attention to the following:

**WARNING!** – Draws attention to hazards, conditions, or procedures that if not observed could result in injury or death.

**CAUTION!** – Draws attention to hazards, conditions, or procedures that if not observed could result in damage to the crane, load, or other equipment. Equipment failure could in turn lead to injury or death.

**NOTE!** – Draws attention to conditions or procedures that are essential to emphasize.

For questions, interpretations, or to report errors, please contact Liftmoore, Inc, Engineering Dept.



F1111-D  
09/30/09

HOUSTON, TEXAS  
FAX: (800) 824-5559 (USA & Canada)  
FAX: (713) 688-6324  
PHONE: (713) 688-5533  
[www.liftmoore.com](http://www.liftmoore.com)

## OPERATING PRACTICES

### OPERATING RESTRICTIONS

#### DUTY CYCLE

For Electric Cranes the duty cycle time should be limited to 10%. This is limited by heat buildup in the motors and declining charge in the batteries. (Installing extra batteries near the crane helps keep the voltage at maximum.)

#### PERSONNEL

LIFTING OR MOVING OF PERSONNEL IS STRICTLY PROHIBITED! This crane was neither designed nor intended to lift personnel. Under no circumstances should anyone be allowed to ride on the crane, line, or load. All non-essential personnel must be kept away when using the crane. The load must never be moved over people, nor must anyone be allowed to pass or stand under a suspended load.

#### ELECTRICAL LINES

Consult ANSI B30.5 for operating procedures, minimum safe distances, and prohibited zones when working around electrical lines or poles.

When operating near electrical power lines, the crane must be positioned so that the distance from the crane to the lines or poles is equal to or greater than the length of the fully extended boom plus the minimum safe distance required.

All parts of the crane, line, and load must be kept a minimum safe distance from electrical power lines and poles. This distance is 10 feet for electrical lines carrying 50kV or less.

**UNDER NO CIRCUMSTANCES SHOULD A CRANE BE OPERATED UNDER ELECTRICAL POWER LINES.**



F1112-E  
07/31/08

#### SETUP

**POSITION** The vehicle must be positioned so that the load is kept as close to the crane base as possible to reduce the moment on the crane. Consideration must be given to starting and ending position as well as firmness and slope of the ground and any obstructions.

**OUTRIGGERS** The outriggers or jackstands must be firmly set and the vehicle as level as possible. This will reduce the stresses on the rotation drive and keep the load off the vehicle's suspension. Keep in mind that the weight on the vehicle will shift as the crane and load is rotated.

**MANUAL BOOM EXTENSION** If the manual extension part of the boom is needed, it must be extended and the boom pin placed in the required position. Insert the pin and replace the pin's hairpin keeper before attempting to lift any load.

**LOAD LIMIT** The operator must understand the crane load chart. The operator must ensure that the load is within the load limits over the entire range which it will be moved. Be sure to include the weight of any lifting devices including the travel block.

The load limit chart is attached to the side of the crane to aid the operator.

The boom angle indicator and chart aids the operator in determining the load capacity at various boom angles and extensions. It also gives the load limit at that configuration.

**STABILITY** A stability chart must be posted near the crane. The operator must understand the stability chart. The crane may be de-rated over some areas of its operating radius.

HOUSTON, TEXAS  
FAX: (800) 824-5559 (USA & Canada)  
FAX: (713) 688-6324  
PHONE: (713) 688-5533  
[www.liftmoore.com](http://www.liftmoore.com)

**TRAVEL BLOCK** The operator must determine if the load is within the single line compatibility of the winch or if a multi-part line configuration is needed.

**REEVING** Ensure the proper routing of the rope through the sheaves and travel block. The rope must lie in the sheave groove and must not rub against any metal objects.

Ensure the rope is correctly wound on the winch drum. The crane assembly drawing will indicate if the rope must be wound over the top or bottom of the drum. The rope must never contact any part of the winch mounting.

### WARNING!

If the winch winding direction is reversed the brake will not work and the load will fall.

### ATTACHING THE LOAD

**POSITION** The boom tip must be moved over the load before lifting so that it will be lifted straight up.

### CAUTION!

Never drag a load with the crane. Dragging a load puts very high stresses on the crane for which it was not designed.

**ROPE** Check the rope condition to ensure it is not frayed or damaged. Ensure that the rope is not kinked and that it does not contact any sharp edges or make any sharp bends.

If using double line configuration, ensure that the lines are not twisted.

### CAUTION!

Never wrap the hoist rope around the load! Serious damage to the rope WILL occur.

**HOOK** Always make sure the load is applied to the throat of the hook. Never use a bent hook.

### CAUTION!

Always lift with the throat of the hook. Never lift with the load applied to the tip of the hook. Doing so will bend the hook.

**SLINGS** If the load does not have a lifting eye, use a nylon, chain, or other type of sling designed for lifting and rated for loads greater than that being lifted.

**BALANCE** Ensure the load will be secure and balanced when lifted. Ensure that the load cannot shift in the sling and that the sling cannot slide across the hook should the load become unbalanced.

### LIFTING THE LOAD

Before lifting, ensure that the load is free from all mountings and is no way attached or stuck to anything.

Ensure that at least five full wraps remain on the winch drum at all times.

Test the winch brake by lifting the load a few inches and ensuring that it does not slip.



F1112-E  
07/31/08

HOUSTON, TEXAS  
FAX: (800) 824-5559 (USA & Canada)  
FAX: (713) 688-6324  
PHONE: (713) 688-5533  
www.liftmoore.com

### **HOLDING THE LOAD**

The operator must keep the load in sight at all times once it is lifted.

The operator must never leave the controls once the load is lifted.

The operator must ensure that no one is allowed to pass or stand under a suspended load.

### **CAUTION!**

Never move the vehicle with a suspended load. Doing so will put dynamic loads on the crane for which it was not designed.

### **MOVING THE LOAD**

Before moving the load, make sure the path is free of any obstructions or people.

Avoid sudden accelerations or stops. Speeds must be kept to a minimum, especially rotation, to keep the load from swinging.

Avoid sudden reversing of direction. Do not reverse direction while the load is still moving.

Make sure that no part of the crane, boom, or load makes contact with any obstruction or comes within a minimum of ten feet from any electrical line.

### **TRANSIT**

While in transit, the crane must be stowed, preferably in a boom rest. The crane must be prevented from rotating and the hook prevented from swinging.



F1112-E  
07/31/08

HOUSTON, TEXAS  
FAX: (800) 824-5559 (USA & Canada)  
FAX: (713) 688-8324  
PHONE: (713) 688-5533  
[www.liftmoore.com](http://www.liftmoore.com)



## INSPECTION AND MAINTENANCE

OSHA and ANSI require frequent and periodic inspections. Records of these inspections must be kept readily available. Liftmoore requires periodic maintenance to ensure proper operation and prolonged life of the crane.

### INSPECTION

#### DAILY INSPECTION

OSHA 29CFR 1910.180 (d)(2)(i) requires the following be checked daily prior to use:

- All control mechanisms for maladjustment interfering with proper operation as well as for excessive wear of components and contamination by lubricants or other foreign matter.
- All safety devices for malfunction. This should include the anti-two block and pressure switch.
- Deterioration or leakage in air or hydraulic systems.
- Crane hooks with deformations or cracks. For hooks with cracks or having more than 15 percent in excess of normal throat opening or more than 10 deg. twist from the plane of the unbent hook.
- Electrical apparatus for malfunctioning, signs of excessive deterioration, dirt, and moisture accumulation. This should include the battery terminals, master disconnect switch, electrical swivel
- The wire rope shall be replaced if any of the following conditions are noted:

- Kinking, crushing, bird-caging, or other damage
- Reductions from nominal diameter of more than one-sixty-fourth inch for diameters up to and including five-sixteenths inch, one-thirty-second inch for diameters three-eighths inch to and including one-half inch.
- Thimble is not in place or is damaged
- Any evidence of heat damage
- Six or more randomly distributed broken wires in 1 lay
- Three or more broken wires in 1 strand in 1 lay

#### MONTHLY INSPECTION

A thorough inspection of all ropes in use shall be made at least once a month and a certification record which includes the date of inspection, the signature of the person who performed the inspection and an identifier for the ropes shall be prepared and kept on file where readily available. All inspections shall be performed by an appointed or authorized person. Any deterioration, resulting in appreciable loss of original strength shall be carefully observed and determination made as to whether further use of the rope would constitute a safety hazard. Some of the conditions that could result in an appreciable loss of strength are the following:

- Reduction of rope diameter below nominal diameter due to loss of core support, internal or external corrosion, or wear of outside wires.
- A number of broken outside wires and the degree of distribution of concentration of such broken wires.



F1113-D  
10/27/10

HOUSTON, TEXAS  
FAX: (800) 824-5559 (USA & Canada)  
FAX: (713) 688-6324  
PHONE: (713) 888-5533  
www.liftmoore.com

- Worn outside wires.
- Corroded or broken wires at end connections.
- Corroded, cracked, bent, worn, or improperly applied end connections.
- Severe kinking, crushing, cutting, or unstranding.

#### PERIODIC INSPECTION

An Annual Inspection Form is included in this manual. OSHA 29CFR 1910.180 (d)(2)ii) requires periodic inspections of this crane. Liftmoore recommends an annual inspection using the included form.

#### MAINTENANCE PRECAUTIONS

The crane should be maintained monthly for safety reasons and to reduce stress on the crane.

#### WARNING!

Never perform any maintenance while the crane has any type of load on it. Use the manual operation procedure to lower the load if necessary.

#### WARNING!

Hydraulic cylinders may have high pressure stored in them even after hydraulic power is removed.

The counterbalance and pilot operated check valve in the cylinder will always hold some pressure in the cylinder. Slightly extending the cylinder then retracting a small amount will relieve most of the pressure in the cylinder. **DO NOT DEADHEAD THE CYLINDER!** This will store the maximum amount of pressure in the cylinder. Care should be taken when either valve is removed from the cylinder as some pressure will still remain.

After any maintenance has been performed the crane shall not be operated until all guards have been reinstalled, all safety

devices reactivated, and maintenance equipment removed.

**LUBRICATION** Refer to the crane specification section for the periodic maintenance schedule and type of lubrication required.

**BOLTS** Bolts may loosen over time due to vibration; therefore they should be checked periodically. If bolts need to be replaced, make sure they are replaced with bolts of equal or greater strength. Check the periodic maintenance schedule (Crane Specification Section) for bolt specification and torque.

#### NOTE!

Sheave and boom and cylinder pivot bolts are not standard bolts. The shank and thread length of these bolts have been modified so that they do not pivot on the threads. Consult the parts section of this manual for part numbers of these bolts.

#### OTHER MAINTENANCE

Refer to parts drawings for any specific maintenance or adjustment procedures such as hydraulic winch brake, rotation drive gear set adjustment, Ect.



## MONTHLY INSPECTION REPORT

Crane Model No. \_\_\_\_\_ Serial Number \_\_\_\_\_

Are Boom Hitch Pins and Keepers in place?	Yes _____ No _____
Wire Line Hook with Safety Latch Working?	Yes _____ No _____
Is Hook OK, (Not bent)?	Yes _____ No _____
Is Thimble on Wire Rope OK?	Yes _____ No _____
Is Traveling Block in use?	Yes _____ No _____
Is Wire Rope OK, not kinked or frayed?	Yes _____ No _____
Are all Boom Sections straight?	Yes _____ No _____
Are Sheave Bolts in place and tight?	Yes _____ No _____
Do all Sheaves rotate easily?	Yes _____ No _____
Are Mounting Bolts tight?	Yes _____ No _____
Is Anti Two-Block functioning properly?	Yes _____ No _____
Is Boom Angle Indicator in place and functioning and is Chart legible?	Yes _____ No _____
Are Cylinder Mounting Bolts secure?	Yes _____ No _____
Are Winch Mounting Bolts tight?	Yes _____ No _____
When stopped does winch drift less than 1.0 Inches?	Yes _____ No _____
Is Load Chart in place and easily read?	Yes _____ No _____
Are functions on Pendant operating correctly?	Yes _____ No _____
Is Hydraulic Reservoir full?	Yes _____ No _____
Is Outrigger straight and functioning?	Yes _____ No _____

Any items checked 'No' must be repaired before using this crane.



F1123-B  
03/26/07

HOUSTON, TEXAS  
 FAX: (800) 824-5559 (USA & Canada)  
 FAX: (713) 688-6324  
 PHONE: (713) 688-5533  
 www.iftmoore.com

THIS PAGE INTENTIONALLY LEFT BLANK



HOUSTON, TEXAS  
FAX: (800) 824-5559 (USA & Canada)  
FAX: (713) 688-6324  
PHONE: (713) 688-5533  
[www.liftmoore.com](http://www.liftmoore.com)

## KMFM CONTROL SYSTEM

KMFM – KAR-TECH MINI FM

The Liftmoore FM control system Model KMFM is a microprocessor-based radio remote control system, which allows wireless crane control. The receiver connects to the standard crane control socket, just like the wired pendant, so it is easily retrofitted and does not prevent use of the standard wired pendant.

### RECEIVER

The receiver features encapsulated electronics for weather resistance and LEDs for user diagnostics. It is mounted to the crane and connects to the crane control socket. Upon user input, the receiver energizes the applicable function valves and/or solenoids, just as the wired pendant does.

### TRANSMITTER

The transmitter is a pocket sized, hand held unit featuring an on/off power switch, push button switches for each function, and two diagnostics LEDs. It is powered by 2 AA Alkaline batteries and includes a power saving feature, which turns itself off if idle for 2 minutes

### DIAGNOSTIC LEDS

There is a green and a red LED located inside the receiver and on the transmitter.

The green LED will blink every ½ second if there is communication between the transmitter and the receiver. It will blink every second if there is no communication.

The transmitter's red LED will blink once every second if the batteries are low and need to be replaced.

Error codes are indicated by a number of flashes of the red LED. For example, 4 blinks and a pause means output number 3 has a problem. See the trouble shooting section for more information.

### MOUNTING

The FM receiver should be mounted so that it is protected from physical damage. It should be as high as possible with the antenna pointing upwards. A temporary mounting method, such as magnets or Velcro, is recommended so that it may be removed when not in use.

### OPERATION

**POWER ON- PRESS AND HOLD POWER BUTTON UNTIL GREEN LIGHT BEGINS FLASHING.**

**POWER OFF- PRESS AND HOLD POWER BUTTON UNTIL GREEN & RED LIGHTS STOP FLASHING.**

### REPLACEMENT OF COMPONENTS

Each transmitter is encoded with a digital ID that is programmed to its specific receiver. The receiver then only accepts signals from that transmitter so multiple cranes may be operated in the same vicinity without interference. If either component needs to be replaced, the receiver must be programmed to accept the new transmitter ID. Contact Liftmoore, Inc. for more information.

### RETROFIT

The system design allows for easy retrofit. The only crane modification required is the simple addition of a ground wire to the control socket. This does not prevent the use of the wired pendant.



F1327-C  
6/30/11

HOUSTON, TEXAS  
FAX: (800) 824-5559 (USA & Canada)  
FAX: (713) 688-6324  
PHONE: (713) 688-5533  
[www.liftmoore.com](http://www.liftmoore.com)

## SAFETY SYSTEM

The safety system is designed to help prevent damage to the crane that would be caused by overload or two-blocking. The system consists of a load sensor, anti-two block device (optional on smaller, electric cranes), and limiting system control board.

When the applicable switch detects an overload or two-block condition, the limiting system will prevent activation of winch up, boom down, and extend out since these directions would cause damage. Winch down, boom up, extend in, and power rotation will still function so that the crane can be moved to a safe configuration.

### CAUTION!

Never de-activate or override safety functions. Doing so can result in serious damage to the crane and possibly injury or death.

## LOAD SENSOR

A pressure activated switch in the elevation cylinder acts as a load sensor. This switch is normally closed and opens at the preset pressure corresponding to the load rating of the crane.

### CAUTION!

The load sensor will not function when the elevation cylinder is fully retracted and is inaccurate when the boom is below horizontal.

### CAUTION!

The operator must never rely strictly on the load sensor to determine overload conditions. The load and load limits must always be known and adhered to.

## MISCELLANEOUS

### UP LIMIT SWITCH

The up limit switch prevents the elevation cylinder from reaching full extension. If the elevation cylinder were to "dead-head", the resulting pressure would activate the load sensor, preventing boom down. The boom would then have to be lowered using the manual operation buttons on the solenoid valves.

### CIRCUIT BREAKER, FUSE

For electric cranes a 150 Amp circuit breaker is supplied with the crane. It should be installed as close to the battery as possible. For hydraulic cranes a 10 Amp blade type fuse is supplied.

### DISCONNECT SWITCH

A power disconnect switch is supplied with the crane. Power to the crane should be turned off whenever not in use. This is to prevent inadvertent or unauthorized use and will help prevent corrosion at electrical connections.



## ELECTRIC HOIST

Permanent Magnet Motor

This Liftmoore crane features an electrically driven planetary gear hoist. The hoist is powered in both directions and features an automatic internal brake to positively control the load.

The hoist is permanently lubricated at the factory. Barring damage or part replacement, no further lubrication is necessary.

### MOTOR

The hoist motor is a permanent magnet, reversible, direct current (DC) motor.

#### CAUTION!

The hoist motor is rated for intermittent duty. Duty cycle is limited to 5 minutes in 30 to allow the motor to cool. Extended use can damage the motor.

#### CAUTION!

When the motor approaches stall, a very rapid heat build up occurs which can cause permanent motor damage. Discontinue use when the motor speed is reduced excessively by voltage drop or load.

### BRAKE

The hoist features a single acting, overrunning brake. It automatically activates to hold the load and assist in lowering the load.

#### WARNING!

The hoist brake only functions in one direction. If the hoisting direction is reversed by reversing the rope winding direction the brake will not hold and the load will fall. Serious injury or death could occur.

The brake is factory set and is not adjustable. If the brake fails to hold the load or if downward drift becomes excessive the brake must be replaced.

### DIRECTIONAL CONTROL

Motor direction is controlled by either a solenoid pack or sealed contactor. Schematically, they are identical - two double pole-double throw solenoids are used to reverse polarity to the motor terminals.

Signal voltage, controlled by the pendant, energizes the selected directional solenoid, directing power to the winch terminal through the normally open terminal. The other terminal remains grounded through the normally closed terminal of the other solenoid.

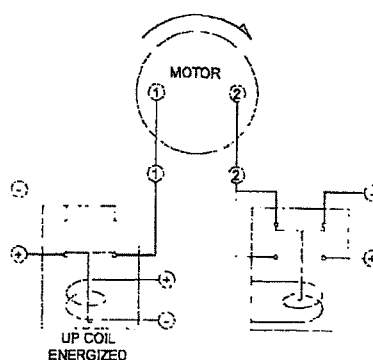
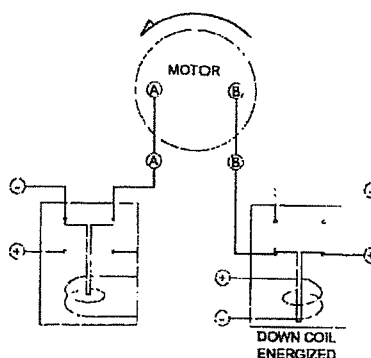

F1239-0  
8/26/04

HOUSTON, TEXAS  
FAX: (800) 824-5559 (USA & Canada)  
FAX: (713) 688-6324  
PHONE: (713) 688-5533  
www.liftmoore.com

## HYDRAULIC SYSTEM FOR ELECTRIC CRANES

The hydraulic system consists of the hydraulic pump, manifold, solenoid valves, cylinders, motors, and tubing and hoses. Hydraulic power is generated by the electrically driven hydraulic pump on the outside of the housing. The hydraulic system is plumbed in series so that more than one function can be operated simultaneously.

### PUMP

The hydraulic pump assembly consists of a DC permanent magnet electric motor, pump, and reservoir.

The motor is activated by the pump solenoid. The solenoid is energized by the pendant control whenever a hydraulic function is activated.

The pump provides fluid pressure to power hydraulic functions. The system incorporates an adjustable relief valve to prevent damage that can be caused by over pressurizing the system.

Fluid is drawn from and returned to the reservoir. Servicing the hydraulic pump consist of maintaining the oil level. The reservoir should be kept as full as possible to prevent condensation from forming inside the tank. Also ensure the oil is not contaminated by water, dirt, rust, etc. See crane specification sheet for hydraulic oil type.

### SOLENOID VALVES

Each hydraulically operated function is controlled by a 4-way, 3-position open center solenoid valve. It is electrically operated and spring biased to center. A manual operation button is incorporated in the coil-retaining nut. Valves are mounted to the series manifold.

### CYLINDERS

Most hydraulic cylinders are double acting cylinders with integrally mounted counterbalance valve and pilot operated check valves. Refer to the cylinder drawings for specific information.

All cylinders use a counter-balance load holding cartridge valve on the extend port.

This valve performs 3 functions:

- Controls the rate of decent when lowering the load
- Keeps load from falling in the event of sudden loss of system pressure, such as when a hose bursts.
- Acts as a relief valve to prevent damage from induced load or thermal expansion.

It allows free flow to extend then blocks flow until opened by pilot pressure to the retract port or when the relief pressure is reached.

Some cylinders utilize a pilot operated check valve on the retract port to prevent the cylinder from creeping out under no load conditions. This valve allows flow into, but prevents flow from the retract port, thus hydraulically locking the cylinder until opened by pilot pressure to the extend port.

### MOTORS

#### THE HYDRAULIC MOTOR USED BY THE ROTATION DRIVE IS A HIGH-TORQUE, LOW-SPEED CONSTANT DISPLACEMENT MOTOR. MANUAL OPERATION

If electrical problems occur the solenoid valves may be operated manually by depressing the manual operation button incorporated in the coil-retaining nut. Using a blunt object such as a bolt or screwdriver handle may be required to assist operation if high pressures are needed. Refer to the manifold drawing for function valves and directions.

If possible, activate the pump by activating a hydraulic function on the pendant. If this does not work, then energize the pump solenoid using a jumper from the hot side of





the solenoid to the coil post where the WHT/BLK wire is connected. If this fails also then battery voltage can be applied directly to the pump motor.

If hydraulic power is lost while a load is suspended, the load can be lowered by decreasing the setting on the counter-balance valve. This should only be done in extreme cases. The valve must be reset before the crane is returned to use.

### **WARNING!**

The boom may fall if the adjustment is made too fast. Do not stand where the boom may hit you if it falls. Serious injury or death may result

### **WARNING!**

The area between the boom and the cylinder, the boom and the housing, and the cylinder and the housing will change as the boom position changes and could form pinch points. Do not position any part of your body in these areas as it may be pinched or crushed as the boom lowers.

To decrease the setting, loosen the locknut on the valve, then slowly turn the adjustment stem **CLOCKWISE** until the load begins to lower. Count the number of turns so that the valve can be returned to its original setting.

Alternately, a pressure gage must be put on the retract port to adjust the setting so that approx. 1800 PSI is required to lower the boom with no load.

Test the setting by lifting a known load near the moment rating.



F1145-C  
10/22/04

HOUSTON, TEXAS 77080  
FAX: (800) 824-5559 (USA & Canada)  
FAX: (713) 688-6324  
PHONE: (713) 688-5533  
[www.liftmoore.com](http://www.liftmoore.com)

## TROUBLESHOOTING KMFM CONTROL SYSTEM

If the crane does not operate, ensure that both the transmitter and receiver are on. Try disconnecting power to the crane receiver then reconnecting.

Run the crane using the wire pendant to confirm that the problem is the wireless unit.

Check that the green transmit light on the transmitter and the green receive light on the receiver light up when a function is selected.

Check for error codes and correct as necessary.

### NOTE!

The green transmit light is located inside the transmitter.

Check that all connectors are secure.

Check for bent pins on the receiver connectors.

If the transmit and receive LEDs are both lit when a function is selected and no error codes are given contact Liftmoore, Inc. for further information.

### Receiver Error Code Chart

	PROBLEM
1	RADIO SIGNAL PROBLEM
2	FAULTY CIRCUIT TO HOIST UP
3	FAULTY CIRCUIT TO HOIST DOWN
4	FAULTY CIRCUIT TO BOOM UP
5	FAULTY CIRCUIT TO BOOM DOWN
6	FAULTY CIRCUIT TO ROTATION CW
7	FAULTY CIRCUIT TO ROTATION CCW
8	FAULTY CIRCUIT TO EXTENSION OUT
9	FAULTY CIRCUIT TO EXTENSION IN
10	FAULTY CIRCUIT TO PUMP RELAY

ERROR CODE NUMBER IS THE NUMBER OF RED LIGHT BLINKS BETWEEN EVERY PAUSE

### Transmitter Error Code Chart

	PROBLEM
1	LOW BATTERY
2	FAULTY CIRCUIT TO HOIST UP
3	FAULTY CIRCUIT TO HOIST DOWN
4	FAULTY CIRCUIT TO BOOM UP
5	FAULTY CIRCUIT TO BOOM DOWN
6	FAULTY CIRCUIT TO ROTATION CW
7	FAULTY CIRCUIT TO ROTATION CCW
8	FAULTY CIRCUIT TO EXTENSION OUT
9	FAULTY CIRCUIT TO EXTENSION IN
10	FAULTY CIRCUIT TO PUMP RELAY

ERROR CODE NUMBER IS THE NUMBER OF RED LIGHT BLINKS BETWEEN EVERY PAUSE.



F1328-A  
4/03/07

HOUSTON, TEXAS  
FAX: (800) 824-5559 (USA & Canada)  
FAX: (713) 688-6324  
PHONE: (713) 688-5533  
www.liftmoore.com

## TROUBLESHOOTING ELECTRIC HOIST

Permanent Magnet, Contactor Controlled

### IMPORTANT NOTE!

The importance of first physically checking every connection between the battery and the crane cannot be overstressed!

Poor connections or poor grounding account for a large percentage of hoist problems. Time is often wasted chasing other probable causes only to eventually find a loose or corroded connection. **Measuring the voltage is not sufficient.** Often a poor connection will allow enough amperage to operate a meter or test light, but not enough to operate the hoist, which requires very high amperage.

If the problem is random and intermittent then it is almost assuredly a loose or bad connection.

Another common problem is low battery voltage. Even if the battery is good when troubleshooting begins, running the winch can quickly drain a battery. If it can be done safely, it is best to have the vehicle running.

Also check the control socket and plug for bent, corroded, or dirty pins.

### CAUTION!

As the motor approaches stall, due to low voltage or excessive load, a very rapid heat build up occurs which will quickly damage the motor. If the motor is not turning, do not operate the switch for more than a second. Allow the motor to cool between attempts to make it run.

## HOIST OPERATES IN ONLY ONE DIRECTION

If the hoist only operates in one direction swap the control wires on the contactor. Activating the pendant switch in the working direction should now operate the hoist in the previous non-working direction.

**Example:** if hoist up is not working, after swapping the control wires activating the hoist down switch should cause the hoist to go up.

If it does then the hoist and contactor are working correctly and the problem is in the pendant crane socket or wiring. If it does not then the problem is the contactor or brake.

If the motor tries to turn but stalls then the problem is most likely the brake. Also, if the contactor makes a clicking noise then that is a good indication that it is working and, again, the problem is most likely the brake.

If the control wires were swapped in the previous step, return them to their original positions. Swap the motor wires (labeled 1 and 2). It is usually easiest to swap them at the motor.

Activating the pendant switch in the working direction should now operate the hoist in the previous non-working direction.

**Example:** if hoist up is not working, after swapping the motor wires activating the hoist down switch should cause the hoist to go up.

If it does, then one side of the contactor is not working and it needs to be replaced.

If it does not work, the problem is a brake malfunction. Inspect the brake installation. Correct any problems found. The brake cannot be repaired. Replace if any damage is found.



F1243-A  
3/28/07

HOUSTON, TEXAS  
FAX: (800) 824-5559 (USA & Canada)  
FAX: (713) 688-6324  
PHONE: (713) 688-5533  
[www.liftmoore.com](http://www.liftmoore.com)

## HOIST DOES NOT RUN IN EITHER DIRECTION

If the hoist does not run in either direction then the problem is either lack of power to the control socket or pendant, lack of sufficient power to the motor, or hoist brake malfunction or motor failure.

If the contactor clicks when the switch is activated then the control socket is getting power.

If all connections have not been checked, do so now. Also ensure that the battery still has sufficient power. As a rule of thumb, if it has enough power to start the engine, then it is good.

Activate the winch toggle switch and check for voltage at motor contacts. If positive voltage is measured at both terminals, the problem may be the ground wire from the contactor. Check for tightness or corrosion on this wire.

Once sufficient power is ensured, if there is any indication that the motor is trying to turn but stalls the problem is the brake – have it replaced.

If there is no indication that the motor is trying to turn and the contactor has been tested, then replace the motor.

## TESTING THE PENDANT AND CONTROL WIRING

If the problem is narrowed to the control wiring, it is most likely caused by a cut or disconnected wire. A visual inspection of the wiring should be made and repairs made as necessary.

Refer to the schematic and pendant drawing for pin functions and locations.

If no visual defects are found and if a continuity tester is available, disconnect the pendant and check for continuity between the control socket pin and terminal at the contactor.

Alternately, a piece of wire or metal object may be used to short between the control socket power pin and the socket hoist pin(s). If the hoist operates then the problem is in the pendant.

If not, check for power at the control socket power pin. If there is no power, trace the wiring back, checking each connection until the problem is found. Correct as necessary.



## TROUBLESHOOTING HYDRAULIC PUMP

Electric Pump, 14P Socket

### IMPORTANT NOTE!

The importance of first physically checking every connection between the battery and the crane cannot be overstressed!

Poor connections or poor grounding account for a large percentage of electrical problems. Time is often wasted chasing other probable causes only to eventually find a loose or corroded connection. **Measuring the voltage is not sufficient.** Often a poor connection will allow enough amperage to operate a meter or test light, but not enough to operate the motor, which requires very high amperage.

If the problem is random and intermittent then it is almost assuredly a loose or bad connection.

Another common problem is low battery voltage. Even if the battery is good when troubleshooting begins, running the motor can quickly drain a battery. If it can be done safely, it is best to have the vehicle running.

Also check the control socket and plug for bent, corroded, or dirty pins.

### CAUTION!

As the motor approaches stall, due to low voltage or excessive load, a very

rapid heat build up occurs which will quickly damage the motor. If the motor is not turning, do not operate the switch for more than a second. Allow the motor to cool between attempts to make it run.

### FOAMY FLUID

If the fluid foams then the problem is the pump seal – have it replaced.

### PUMP DOES NOT RUN

If both the pump and winch are not working, the problem is power related or control wiring related. Troubleshoot those areas first.

If the solenoid is actuating it will make a clicking noise. If the solenoid is not clicking, check for power at the coil input (small screw terminal) on solenoid when the Boom Up switch is activated. If there is no power then the problem is the electrical wiring harness or pendant control wiring.(refer. to CONTROL TROUBLESHOOTING CHART).

If the coil is getting power when the switch is activated, but not clicking then the problem is most likely the solenoid.

If the solenoid is clicking check for full power input to the solenoid. Trace the wiring back to the crane input, checking for power at each connection until the problem is found. If full electrical power to the motor is confirmed then the motor is faulty and should be replaced.



F1255-B  
01-10-11

HOUSTON, TEXAS  
FAX: (800) 824-5559 (USA & Canada)  
FAX: (713) 688-6324  
PHONE: (713) 688-5533  
www.liftmoore.com

## LIMITING SYSTEM

### DESCRIPTION:

Liftmoore Limiting system (LS) is a micro processor-based control system designed to aid the machine operator by providing an overload shutoff mechanism. This system monitors the BOOM ANGLE and PRESSURE SENSOR inputs. By comparing these values to a built in Load Chart, The LS determines if the boom is in a safe operating position where all the functions are safe to operate, or if the boom in an unsafe position where some functions are disabled.

The LS controller operates the WINCH UP, EXTENSION OUT, ELEVATION UP, and ELEVATION DOWN valves.

When operating in a safe position, all four functions follow their dedicated inputs. For example, when the ELEVATION UP INPUT is connected to BATTERY+, the ELEVATION UP OUTPUT turns ON, and when the ELEVATION UP INPUT is disconnected, the ELEVATION UP OUTPUT turns OFF.

When operating in an unsafe position, determined from the BOOM ANGLE and PRESSURE SENSOR, the WINCH UP, EXTENSION OUT, ELEVATION DOWN and ELEVATION UP outputs are deactivated and will remain OFF as long as the LS detects the unsafe condition. When ATB switch input is 0 volt, switch open, WINCH UP and EXTENSION OUT, outputs are deactivated.

The overload system is just a feature to aid the operator. The machine operator is still required to follow the load chart, OSHA and other applicable standards when operating the equipment in which this product is installed.

The control system consists of a controller board inside an enclosure. All external connections are made by the 12-pin sealed Deutsch connector.

### ON/OFF OUTPUTS:

The LS Controller is designed with four on/off outputs with three ampere capacity and LED Status light. Each on/off is designed with short circuit and overload protection. In case of a short circuit or over load, the output is turned off and the status is displayed on the Error Code LED.

F2202-0  
10/1/14



HOUSTON, TEXAS  
FAX: (800) 824-5559 (USA & Canada)  
FAX: (713) 688-6324  
PHONE: (713) 688-5533  
[www.liftmoore.com](http://www.liftmoore.com)

These outputs are designed to turn on and off corresponding to four switch inputs. Please refer to connection information and Error Code chart section of this manual.

**ON/OFF INPUTS:**

The LS controller is designed with 5 digital (switched to 12 VDC) inputs. Each input is protected from transient voltages up to 60 VDC. Refer to connection information in this manual for additional information.

**ANALOG INPUTS:**

The analog (proportional) inputs are provided to get signals from the Angle Sensor and the Pressure Sensor. The input range is 0.3 to 4.5 VDC (60 V transient). If any of the wires to the sensors are disconnected, the system will consider the situation is unsafe and will disable the outputs. An error code will be flashed on the Error Code LED. For additional information refer to Error Code chart and connection information in this manual.

**WATCH DOG TIMERS:**

The LS controller is designed with a “watch dog timer” for monitoring the regulated supply voltage and software execution. If the software program halts for any reason, or the voltage drops below specified value, the controller is returned to the reset state (all outputs off).

**STATUS INDICATORS:**

The control unit is equipped with two status indicator LEDs, one red and one green. If there is an error, the red LED flashes a certain number of times to indicate which error has occurred. Count the number of times the red LED flashes and refer to the error code chart on page 12 of this manual to determine the specific error. When there is no error, the green LED flashes to signify that the system is operating normally.



F2202-0  
10/1/14

HOUSTON, TEXAS  
FAX: (800) 824-5559 (USA & Canada)  
FAX: (713) 688-6324  
PHONE: (713) 688-5533  
[www.liftmoore.com](http://www.liftmoore.com)

**LIMITING SYSTEM**  
**CONNECTION INFORMATION**

**Connector: DTM13-12PA**

<u>PIN#</u>	<u>DESCRIPTION</u>
A	GROUND
B	ANGLE SENSOR INPUT
C	ELEVATION UP OUTPUT
D	ELEVATION UP SWITCH INPUT
E	PRESSURE SENSOR INPUT
F	WINCH UP SWITCH INPUT
G	ELEVATION DOWN SWITCH INPUT
H	EXTENSION OUT SWITCH INPUT
J	EXTENSION OUT OUTPUT
K	ELEVATION DOWN OUTPUT
L	WINCH UP OUTPUT
M	ATB SWITCH INPUT
N	SUPPLY (9 TO 30 VDC)

F2203-0  
10/1/14



HOUSTON, TEXAS  
FAX: (800) 824-5559 (USA & Canada)  
FAX: (713) 688-6324  
PHONE: (713) 688-5533  
[www.liftmoore.com](http://www.liftmoore.com)



## LIMITING SYSTEM

### ROUTINE MAINTENANCE:

1. Inspect electrical wiring for wear points or other damage. Repair as required.
2. Inspect all connections (especially those on the valves) for looseness or corrosion. Tighten and/or seal as necessary.

### MAINTENANCE PRECAUTIONS:

When performing any inspection or maintenance work on the system, always exercise care to prevent injury to yourself and others or damage to the equipment. The following are general precautions which should be closely followed in carrying out any maintenance work:

1. Do not have hydraulic pressure available to the valves when performing electrical tests.
2. Never operate or test any function if a person is in close proximity of the equipment, and could be injured if that function operated.
3. Take care to prevent metal tools from coming in contact with sensitive electronic components.
4. Turn power off before connecting or disconnecting valve coils or other electrical loads.

F2204-0  
10/1/14



HOUSTON, TEXAS  
FAX: (800) 824-5559 (USA & Canada)  
FAX: (713) 688-6324  
PHONE: (713) 688-5533  
[www.liftmoore.com](http://www.liftmoore.com)

**LIMITING SYSTEM  
TROUBLE SHOOTING CHART**

<b>PROBLEM</b>	<b>PROBABLE CAUSE</b>	<b>SOLUTION</b>
1. Control will not operate when any switches are activated. No LEDs ON or Flashing.	<i>MISSING POWER TO THE SYSTEM.</i>	<ol style="list-style-type: none"> <li>1. Check that power switch is on.</li> <li>2. Check fuse supplying power to the control unit.</li> <li>3. Check vehicle wiring for power into the control.</li> <li>4. Check for proper grounding of vehicle's electrical circuit.</li> <li>5. Check vehicle's hydraulic system.</li> <li>6. Check crimped connections. Make sure connectors are in proper alignment and seated correctly</li> </ol>
2. Control will not operate when any switches are activated.	<i>ANGLE SENSOR OR PRESSURE SENSOR NOT WIRED CORRECTLY OR NOT FUNCTIONING PROPERLY</i>	<ol style="list-style-type: none"> <li>1. Check vehicle wiring for power into the control.</li> <li>2. Check that the Angle and/or Pressure sensors are on and supplying power to controller connector pin 2 and 5.</li> <li>3. Check Error Code LED.</li> <li>4. Check vehicle's hydraulic system.</li> </ol>
3. Control will not operate when any switches are activated.	<b>BOOM IN "UNSAFE" REGION ATB CONDITION</b>	<ol style="list-style-type: none"> <li>1. <b>RETRACT BOOM AND/OR LOWER WINCH TO REDUCE PRESSURE.</b></li> <li>2. Check ATB switch input for 12 volts.</li> <li>3. Check wiring connections to the valve coil.</li> <li>4. Check Error Code LED for system status.</li> <li>5. Check vehicle's hydraulic circuit.</li> </ol>

F2205-0  
10/1/14



HOUSTON, TEXAS  
 FAX: (800) 824-5559 (USA & Canada)  
 FAX: (713) 688-6324  
 PHONE: (713) 688-5533  
[www.liftmoore.com](http://www.liftmoore.com)

**LIMITING SYSTEM  
TROUBLE SHOOTING CHART**

<b>PROBLEM</b>	<b>PROBABLE CAUSE</b>	<b>SOLUTION</b>
4. Function operates intermittently.	<i>FAULTY CONNECTIONS</i>	<ol style="list-style-type: none"><li>1. Loose connection at the sensors and/or switches.</li><li>2. Loose connector at the valve coils.</li><li>3. Check Error code LED for system status.</li><li>4. Check vehicle electrical circuit for loose connection.</li><li>4. Check vehicle hydraulic circuit.</li></ol>



F2205-0  
10/1/14

HOUSTON, TEXAS  
FAX: (800) 824-5559 (USA & Canada)  
FAX: (713) 688-6324  
PHONE: (713) 688-5533  
[www.liftmoore.com](http://www.liftmoore.com)

**LIMITING SYSTEM**  
**ERROR CODE CHART**

To display an error code, the controller turns on and off the error code LED (RED LED) a certain number of times with a pause at the end. It repeats the code until the problem is resolved. The following error code chart is provided to assist the service personnel in troubleshooting the system. If more than one error condition is present, the error code with the lower number will be displayed.

ERROR CODE COUNT	PROBABLE CAUSE
1	PRESSURE SENSOR INPUT OUT OF RANGE
2	ANGLE SENSOR INPUT OUT OF RANGE
3	OVERLOAD CONDITION
4	SHORT OR OVER LOAD ON ELEVATION UP OUTPUT
5	SHORT OR OVER LOAD ON ELEVATION DOWN OUTPUT
6	SHORT OR OVER LOAD ON EXTENSION OUT OUTPUT
7	SHORT OR OVER LOAD ON WINCH UP OUTPUT

F2206-0  
10/1/14



HOUSTON, TEXAS  
FAX: (800) 824-5559 (USA & Canada)  
FAX: (713) 688-6324  
PHONE: (713) 688-5533  
[www.liftmoore.com](http://www.liftmoore.com)

LIMITING SYSTEM  
PARTS LIST

PART NUMBER	DESCRIPTION
25863	LIMITING SYSTEM (CIRCUIT BOARD)
24866	BOOM ANGLE SENSOR
24456	5000 PSI PRESSURE SENSOR
24867	PRESSURE SENSOR HARNESS

F2207-0  
10/1/14



HOUSTON, TEXAS  
FAX: (800) 824-5559 (USA & Canada)  
FAX: (713) 688-6324  
PHONE: (713) 688-5533  
[www.liftmoore.com](http://www.liftmoore.com)

LIMITING SYSTEM  
SPECIFICATIONS

Power supply voltage ..... 12V nominal, 9V to 35V transient  
Operating temperature ..... -40C to +85C  
Storage temperature ..... -40C to +100C  
Digital Inputs ..... 12VDC, 60V transient  
Analog Inputs ..... 0.3 to 2.5VDC, 60V transient  
Outputs ..... 3 Amps

There are no user-serviceable parts inside the controller. Return the units to the KAR-TECH for service.

The information, specifications, and illustrations in this manual are those in effect at the time of printing. KAR-TECH reserves the right to change specifications or design at any time without notice.

F2208-0  
10/1/14



HOUSTON, TEXAS  
FAX: (800) 824-5559 (USA & Canada)  
FAX: (713) 688-6324  
PHONE: (713) 688-5533  
[www.liftmoore.com](http://www.liftmoore.com)

### Appendix A: ANGLE SENSOR SETUP

THE JUMPERS ON THE CONTROL BOARD ARE USED TO CALIBRATE THE ANGLE SENSOR (SEE FIG. 1.0). THIS PROCEDURE SHOULD BE DONE DURING INITIAL INSTALLATION AND ANY TIME THE ANGLE SENSOR IS MOVED OR REPLACED.

- 1) INSTALL THE ANGLE SENSOR AT +15 DEGREES ON THE RIGHT SIDE OF THE BOOM (PIVOT TO SENSOR'S LEFT).
- 2) PLACE THE JUMPER TO THE "-45 DEGREE" POSITION.
- 3) THE RED LED SHOULD BE ON SOLID AND THE GREEN LED OFF.
- 4) MOVE THE BOOM DOWN TO -45 DEGREES.
- 5) BOTH THE LEDS SHOULD BE BLINKING. IF NOT, THE SENSOR IS EITHER MISWIRED OR NOT MOUNTED CORRECTLY (CHECK SENSOR OUTPUT VOLTAGE FOR .5 TO .6 VOLTS).
- 6) REMOVE THE JUMPER. BOTH LEDS WILL STAY ON SOLID FOR 3 SECONDS.
- 7) PLACE THE JUMPER TO THE "+70 DEGREE" POSITION.
- 8) THE GREEN LED SHOULD GO ON SOLID AND THE RED LED OFF.
- 9) MOVE THE BOOM UP TO 70 DEGREES.
- 10) BOTH LEDS SHOULD BE BLINKING. IF NOT, THE SENSOR IS EITHER MISWIRED OR NOT MOUNTED CORRECTLY (CHECK SENSOR OUTPUT VOLTAGE FOR 4.3 TO 4.5 VOLTS).
- 11) REMOVE THE JUMPER. BOTH LEDS SHOULD STAY ON SOLID FOR 3 SECONDS.
- 12) PUT THE JUMPER BACK IN THE STORAGE POSITION (SEE FIG. 1.0).

F2209-0  
10/1/14



HOUSTON, TEXAS  
FAX: (800) 824-5559 (USA & Canada)  
FAX: (713) 688-6324  
PHONE: (713) 688-5533  
[www.liftmoore.com](http://www.liftmoore.com)

(FIG. 1.0)

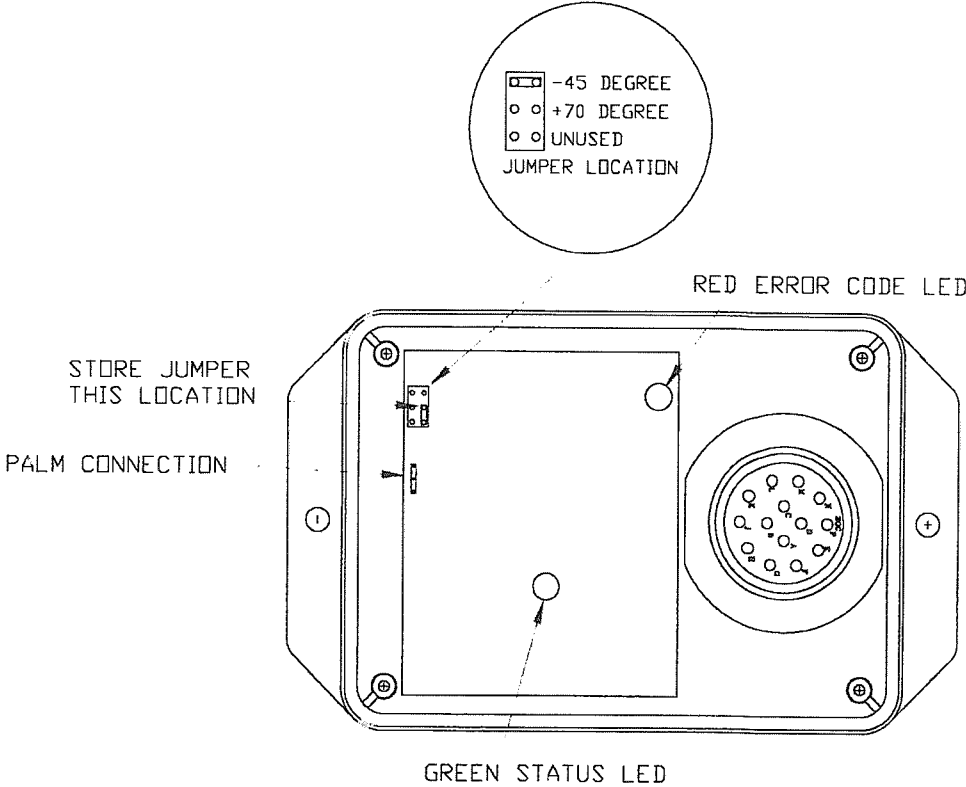

F2209-0  
10/1/14

HOUSTON, TEXAS  
FAX: (800) 824-5559 (USA & Canada)  
FAX: (713) 688-6324  
PHONE: (713) 688-5533  
[www.liftmoore.com](http://www.liftmoore.com)



Appendix B: WIRING DIAGRAM

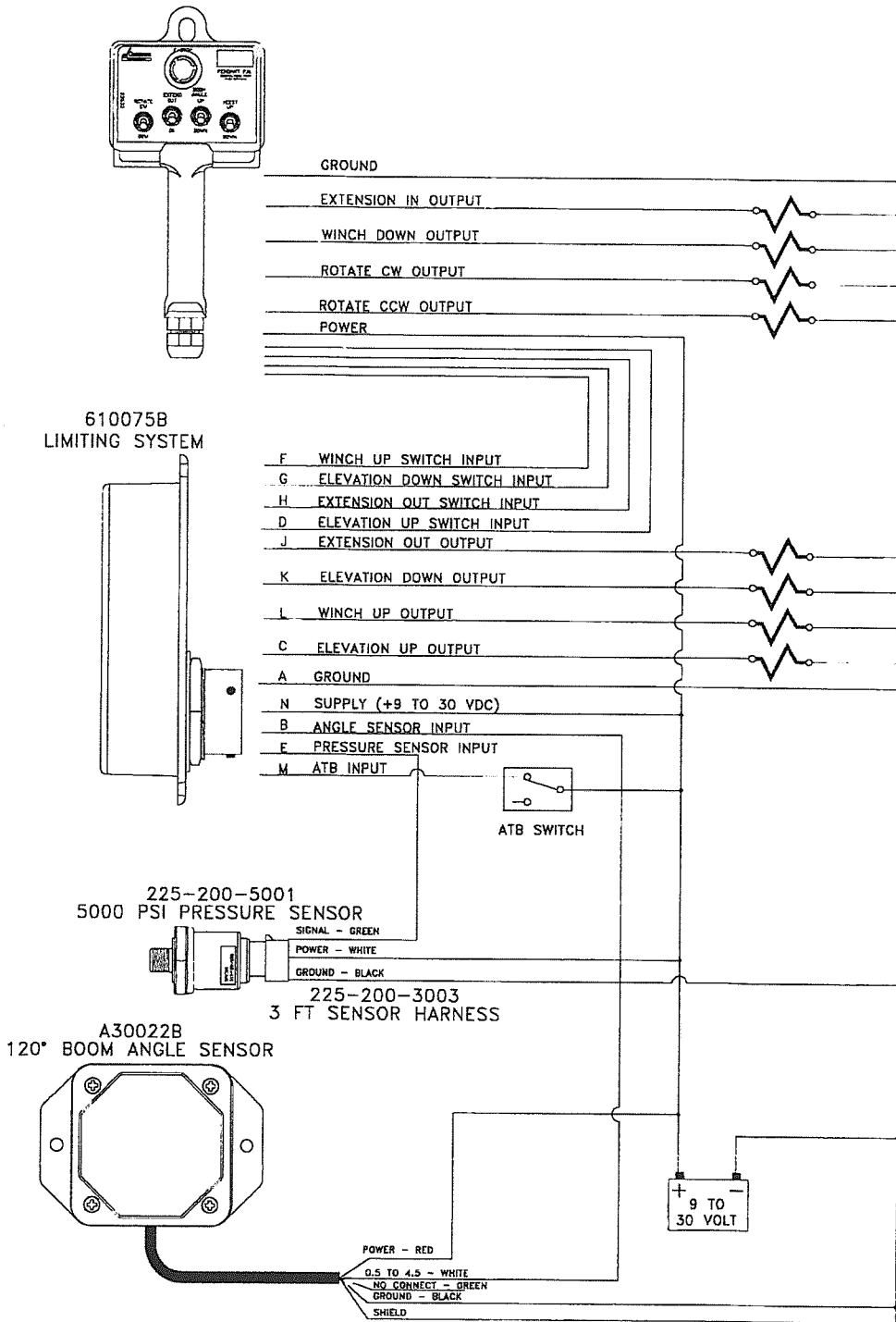

F2210-0  
10/1/14



HOUSTON, TEXAS  
 FAX: (800) 824-5559 (USA & Canada)  
 FAX: (713) 688-6324  
 PHONE: (713) 688-5533  
 www.liftmoore.com

THIS PAGE INTENTIONALLY LEFT BLANK



HOUSTON, TEXAS  
FAX: (800) 824-5559 (USA & Canada)  
FAX: (713) 688-6324  
PHONE: (713) 688-5533  
[www.liftmoore.com](http://www.liftmoore.com)

## SECTION 3 CRANE SPECIFICATIONS

### MODEL LA6K EX-11 CRANES

MOMENT RATING                    6000 FT-LBS

MAX SINGLE LINE LOAD        1 000 LBS

MAX DOUBLE LINE LOAD       2000 LBS

LIFTING CAPACITIES AT VARIOUS LOAD RADII:

LOAD RADIUS (FT)	CAPACITY (LBS)
≤ 3.2	1875
4	1500
7	857
9	666
11	545

POWERED FUNCTIONS AND EXPECTED TIMES:

WINCH	UP:    N/A s	DOWN: N/A s	3 REVOLUTION
BOOM ELEVATION	UP:    N/A s	DOWN: N/A s	
BOOM EXTENSION	OUT:  N/A s	IN:     N/A s	
ROTATION	90°	N/A s	

ELECTRICAL:

VOLTAGE	12 VDC
FUSE	15 AMP
CIRCUIT BREAKER	150 AMP

NOTE: FUNCTION TIMES ARE BASED ON THESE INPUT VALUES

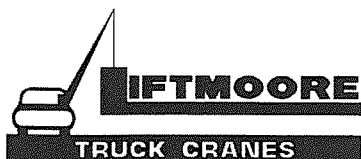

F1830-0  
04/04/11

HOUSTON, TEXAS  
FAX: (800) 824-5559 (USA & Canada)  
FAX: (713) 688-6324  
PHONE: (713) 688-5533  
[www.liftmoore.com](http://www.liftmoore.com)

<b>PERIODIC MAINTENANCE SCHEDULE</b>		
MODEL LA6K CRANES		
BOLTS		
<b>MOUNTING BOLTS</b>	1/2-13 GRADE 8 TORQUE 110 FT-LBS DRY	EVERY 4 MONTHS
<b>LUBRICATION</b>		
<b>GREASE FITTINGS</b>	SEE DRAWING	EVERY OTHER WEEK
<b>HYDRAULIC FLUID</b>	STANDARD Chevron AW Hydraulic Oil 46 or equivalent SAE 15 weight oil  COLD WEATHER AW 32 or equivalent SAE 10 weight oil	CHECK DAILY, FILL AS NEEDED
<b>BEARINGS</b>	Oil Center Research PM 600 Military grease or equivalent Benton Based Grease NLGI Grade 2	EVERY 6 HOURS OF OPERATION
<b>BOOM</b>	Coat with "Slip Plate" made by Superior Graphite or similar solid lubricant coating	AS NEEDED

**OTHER MAINTENANCE****ROTATION GEAR SETTING**

See the Rotation Components drawing for adjustment procedure if backlash becomes so great that excessive boom movement occurs. Factory setting is such that the displacement of the retracted boom tip is less than 1 inch.

**WINCH**

The winch is factory lubricated and should not require further lubrication in its lifetime. The winch brake cannot be adjusted. If brake drift is more than 1 inch under full load then it must be replaced.



F1830-0  
04/04/11

HOUSTON, TEXAS  
FAX: (800) 824-5559 (USA & Canada)  
FAX: (713) 688-6324  
PHONE: (713) 688-5533  
[www.liftmoore.com](http://www.liftmoore.com)

# CRANE LUBRICATION POINTS

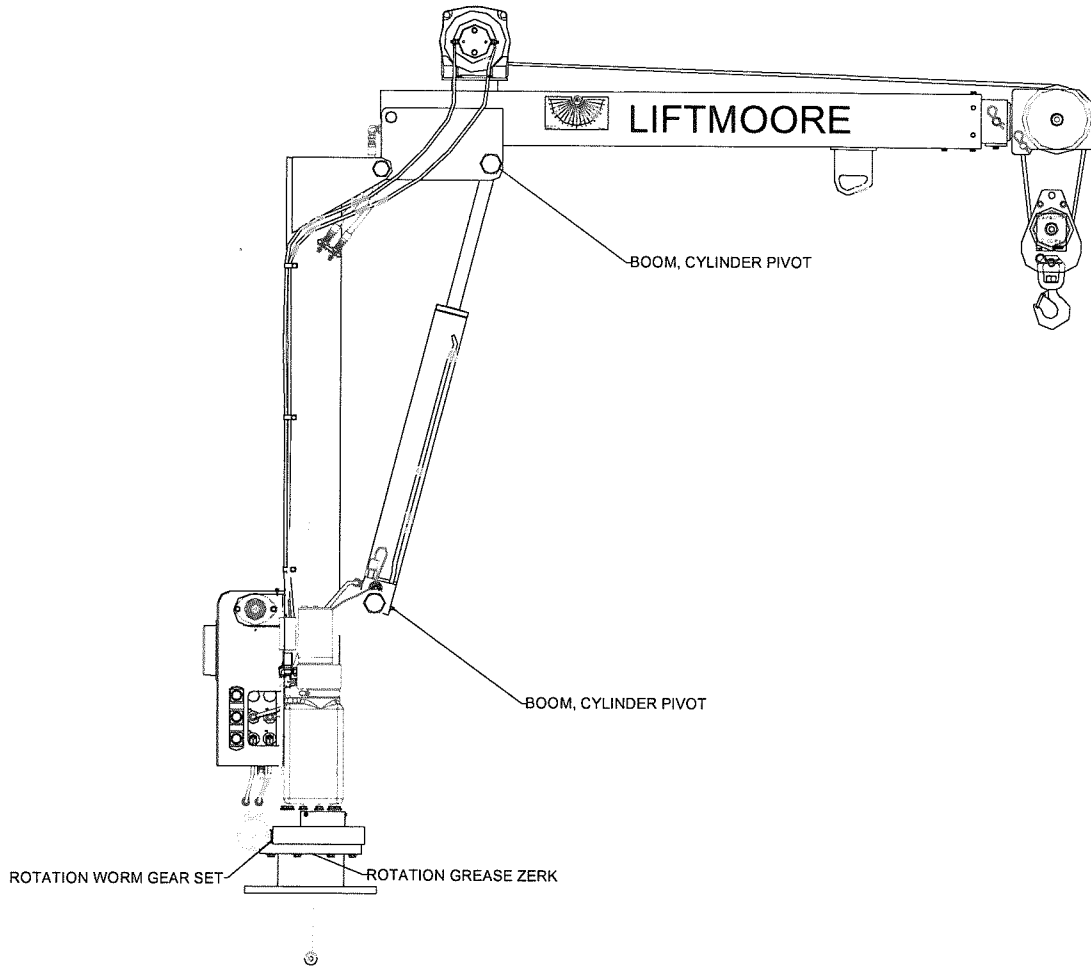

F1830-0  
04/04/11

HOUSTON, TEXAS  
FAX: (800) 824-5559 (USA & Canada)  
FAX: (713) 688-6324  
PHONE: (713) 688-5533  
www.liftmoore.com

THIS PAGE INTENTIONALLY LEFT BLANK



F1830-0  
04/04/11

HOUSTON, TEXAS  
FAX: (800) 824-5559 (USA & Canada)  
FAX: (713) 688-6324  
PHONE: (713) 688-5533  
[www.liftmoore.com](http://www.liftmoore.com)

## LIST FOR BOX, CRANE PARTS LA6K EX-11

Items with \* have detailed DWG's.

P/N 27363 - BOX, CRANE PARTS LA6K EX-11  
BULLSEYE LEVEL & GAUGE W/ BAIL ATB, VOLTMETER

- 1) P/N 27364 - MANUAL, CRANE LA6K EX-11.....1pc
- 2) P/N 33021 - WIRE, BATTERY #1 X 25' W\MECON.....1pc
- 3) P/N 30728 - WIRE, GROUND #4 X 3' LONG.....1pc
- 4) P/N 30760 - PIN, HITCH 0.75 X 4.50 W/H-PIN.....1pc
- 5) P/N 30815 - SCREW, HHC 0.50-13 X 2.50 GR8.....4pcs
- 6) P/N 30474 - WASHER, LOCK 0.50 GR5 PLATED.....4pcs
- 7) P/N 31957 - NUT, HEX 0.50-13 GR8 PLATED.....4pcs
- 8) \*P/N 23697 - BLOCK, TRAV ASSY 2.0K lbs/4.0D. ....1pc
- 9) P/N 16878 - BREAKER, CIRCUIT 150 AMP.....1pc
- 10) P/N 16915 - TERMINAL, LUG #1 GA 0.25 DIA.....2pcs
- 11) P/N 30766 - SWITCH, DISCONNECT.....1pc
- 12) P/N 17010 - BRACKET, SWITCH MNT. ELE. CRN.....1pc
- 13) P/N 17063 - TERMINAL, LUG #1 GA 0.37 DIA.....2pcs
- 14) P/N MH\*03171 - CAP, BREATHER 3/8 NPT-MONARCH.....1pc
- 15) P/N 22571 - INSTALLATION INTS. 206 & LA6K .....1pc
- 16) P/N 24977 - DECAL, LOAD CAPACITY LA6K.....1pc
- 17) P/N 23144 LEVEL AND TAPE ASSEMBLY.....1pc



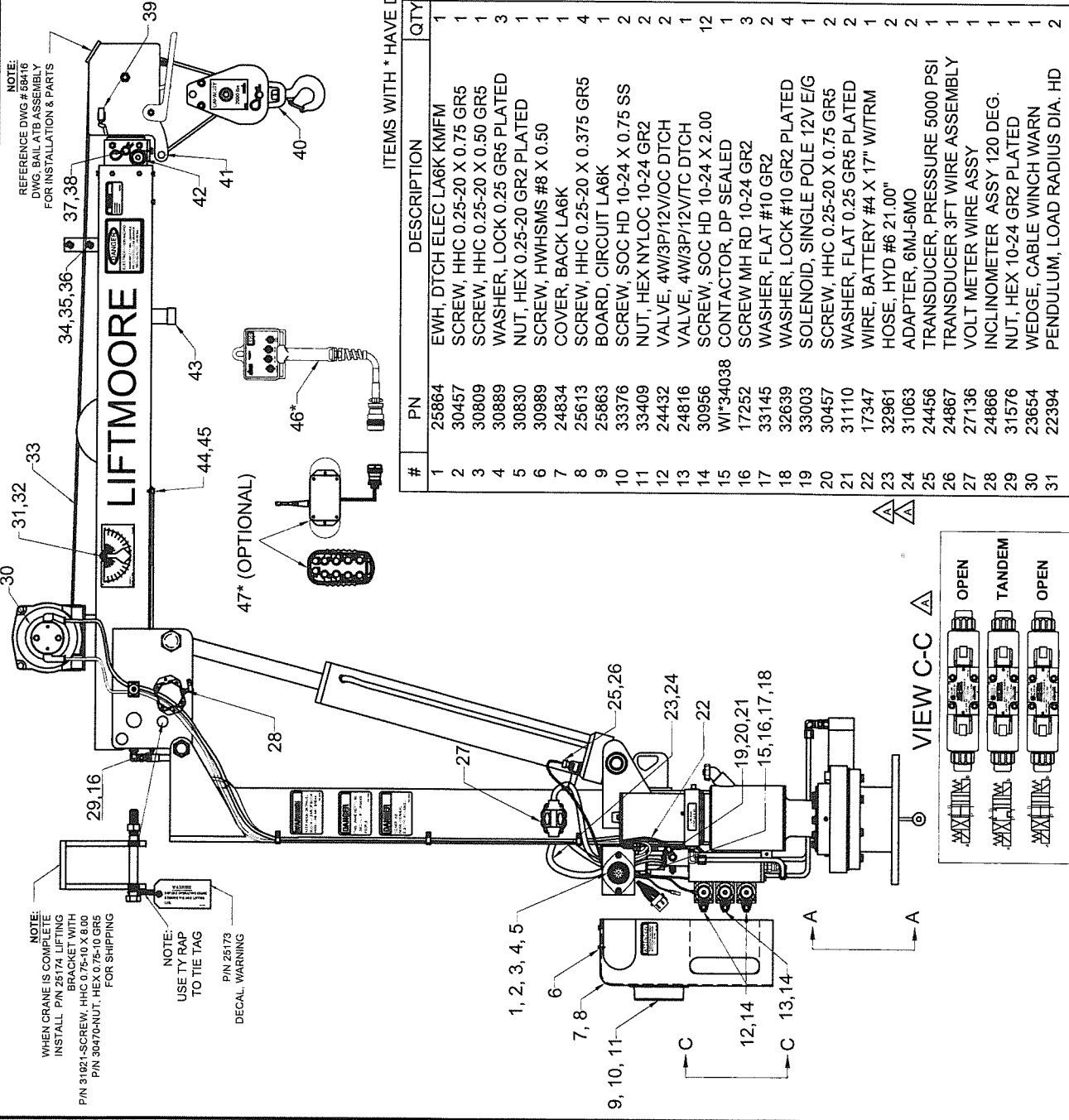

NOTE:  
WHEN CRANE IS COMPLETE  
INSTALL PIN 25174 LIFTING  
HOOK AND PIN 25173  
FOR SHIPPING

NOTE:  
USE TY RAP  
TO TIE TAG

PIN 25173  
DECAL WARNING

NOTE:  
REFERENCE DWG #58416  
DWG. BAIL ATB ASSEMBLY  
FOR INSTALLATION & PARTS

47\* (OPTIONAL)

48,49,50

INSTALL ITEMS # 48,49,50 ON PRESSURE  
PORT OF PUMP.

ITEMS WITH \* HAVE DETAIL DRAWINGS

#	PN	DESCRIPTION	QTY	#	PN	DESCRIPTION	QTY
1	25864	EWH, DTCH ELEC LA6K KMFM	1	32	31017	SCREW, SHOULDER 0.31-18 X 0.75	2
2	30457	SCREW, HHC 0.25-20 X 0.75 GR5	1	33	20203	ROPE, WIRE 0.18 X 50' W/TH&LP	1
3	30809	SCREW, HHC 0.25-20 X 0.50 GR5	1	34	24366	ROLLER, ROPE LA6K NYLON	2
4	30889	WASHER, LOCK 0.25 GR5 PLATED	3	35	24367	SCREW, HHC 0.25-20 X 5.50 GR5	2
5	30830	NUT, HEX 0.25-20 GR2 PLATED	1	36	30833	NUT, HEX NYLOC 0.25-20 GR2	2
6	30989	SCREW, HWHSMS #8 X 0.50	1	37	31603	CLIP, HAIRPIN 0.50 - 0.62	1
7	24834	COVER, BACK LA6K	1	38	33203	PIN, HITCH 0.75 X 6.00 W/H-PIN	1
8	25613	SCREW, HHC 0.25-20 X 0.375 GR5	4	39	19847	CONNECTOR, DTCH 2P PLUG	1
9	25863	BOARD, CIRCUIT LA6K	1	40	23697	BLOCK, TRAV ASSY 2.0K LBS/4.0D	1
10	33376	SCREW, SOC HD 10-24 X 0.75 SS	2	41	22553	PIN, CLEVIS 0.56 X 2.5 PLATED	1
11	33409	NUT, HEX NYLOC 10-24 GR2	2	42	24435	STOP, BOOM INNER ASSY STD.	1
12	24432	VALVE, 4W/3P/12V/OC DTCH	2	43	20922	BUMPER, RUBBER RECESSED 1.5"	1
13	24816	VALVE, 4W/3P/12V/TC DTCH	1	44	24960	CLAMP, HOSE SUPPORT 0.25 ID	2
14	30956	SCREW, SOC HD 10-24 X 2.00	12	45	26582	SCREW, SOC HD 0.25-20 X 0.37SS	2
15	W1*34038	CONTACTOR, DP SEALED	1	46	25181	CONTROL, PENDANT LA6K	1
16	17252	SCREW MH RD 10-24 GR2	3	47	23821	BOX, FM PARTS KT MEGA ELE I/O 14P	1
17	33145	WASHER, FLAT #10 GR2	2	48	23123	PRESSURE GAUGE, 0-3000 PSI	1
18	32639	WASHER, LOCK #10 GR2 PLATED	4	49	23135	ADAPTER, 4FP-6FJ SWIVEL	1
19	33003	SOLENOID, SINGLE POLE 12V E/G	1	50	31513	ADAPTER, 90° 6MJ-6FJX	1
20	30457	SCREW, HHC 0.25-20 X 0.75 GR5	2				
21	31110	WASHER, FLAT 0.25 GR5 PLATED	2				
22	17347	WIRE, BATTERY #4 X 17" W/TRM	1				
23	32961	HOSE, HYD #6 21.00"	1				
24	31063	ADAPTER, 6MJ-6MO	2				
25	24456	TRANSDUCER, PRESSURE 5000 PSI	1				
26	24867	TRANSDUCER 3FT WIRE ASSEMBLY	1				
27	27136	VOLT METER WIRE ASSY	1				
28	24866	INCLINOMETER ASSY 120 DEG.	1				
29	31576	NUT, HEX 10-24 GR2 PLATED	1				
30	23654	WEDGE, CABLE WINCH WARN	1				
31	22394	PENDULUM, LOAD RADIUS DIA. HD	2				

\*\* ITEMS NOT SHOWN:-  
SWITCH, LIMIT ATB ASSY 2W DTCH 1  
SCREW, SOC HD 10-24 X 1.00 2  
BOOT, RUBBER 1 & 1/0 1  
DECAL KIT LA6K 1  
EWH, PUMP SOL. / CONTACTOR GND 1  
WIRE, BATTERY #4 X 5" 1  
WIRE, BATTERY #4 X 5" W/TERMS 1  
EWH, CONTACTOR DTCH 1

**LIFTMOORE**  
TRUCK CRANES

Houston TX  
(713)-688-5533  
www.liftmoore.com

DRWNBY: AA  
DATE: 05/28/15

**CRANE ASSY LA6K-11 REE ATB**  
BAIL ATB, INCLINOMETER & TRANSDUCER, 3.08 ROT. MOTR, V METER

DRAWING NO. **27362-A**



ATTACH THE FOLLOWING TAG TO THE PENDANT HERE

P/N 25173  
WARNING-BEFORE OPERATING REMOVE PIN & LIFTING LUG

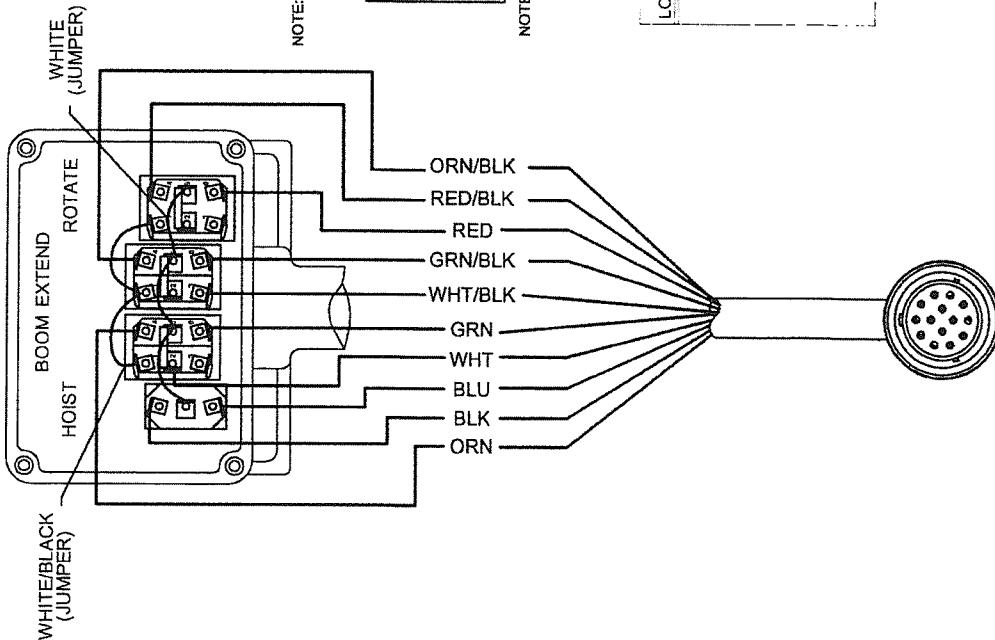

PENDANT BOX BACK COVER - KT\*310034A  
(Ref. p/n 17593)

P/N 17593  
BOX, CONTROL-PISTOL GRIP-SM-KT

P/N 19315  
DECAL, CONTROL 4 FUNCTION KT

NOTE: JUMPER WIRES ARE 16 GA BLK/WHT WIRE P/N 15826.

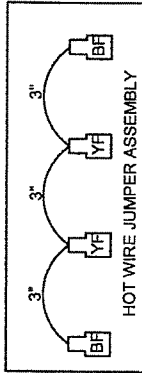
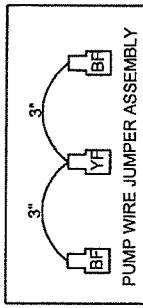

NOTE: JUMPER WIRES ARE 16 GA WHITE WIRE P/N 15151.

P/N30454 (x3)  
SWITCH, TOGGLE DPDT MOM.W/JUMP

P/N 30453  
SWITCH, TOGGLE SPDT MOMENTARY

P/N 22558  
CONNECTOR, CGB 3/4 NPT FLEX

P/N 20127  
WIRE, CTRL W/PLG 14/10 18'  
NOTE: REPLACEMENT PLUG  
TO BE P/N 19876

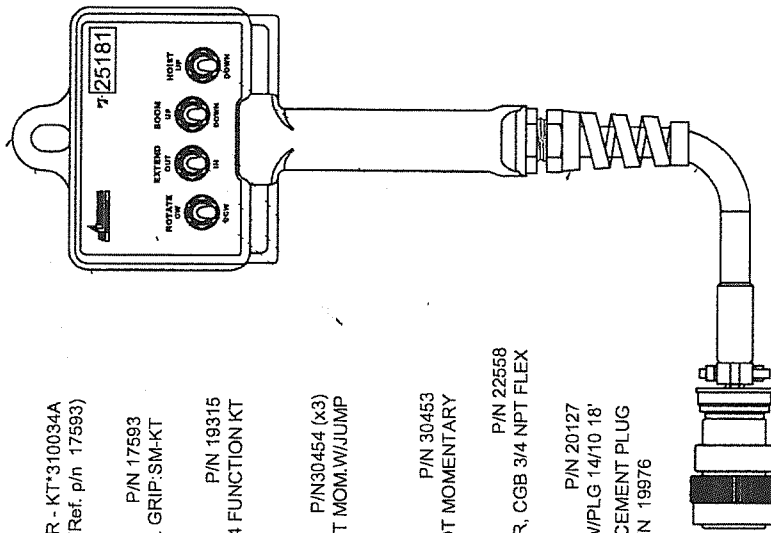

PIN LOCATION	WIRE FUNCTION	WIRE COLOR
E	POWER	WHT
F	ROTATION CW	RED
G	ELEV UP	GRN
H	ELEV DWN	ORN
J	HOIST UP	BLU
K	PUMP SOLN.	WHT/BLK
L	ROTATION CCW	RED/BLK
M	EXTEND OUT	GRN/BLK
N	EXTEND IN	ORG/BLK
P	HOIST DOWN	BLK

Houston TX  
(713)-688-5533  
www.lifmoore.com



DRWN BY: JE

DATE: 9/20/12

CONTROL, PENDANT LA6K  
18' CORD 14-PIN DEUTSCH

DRAWING NO.

25181-0

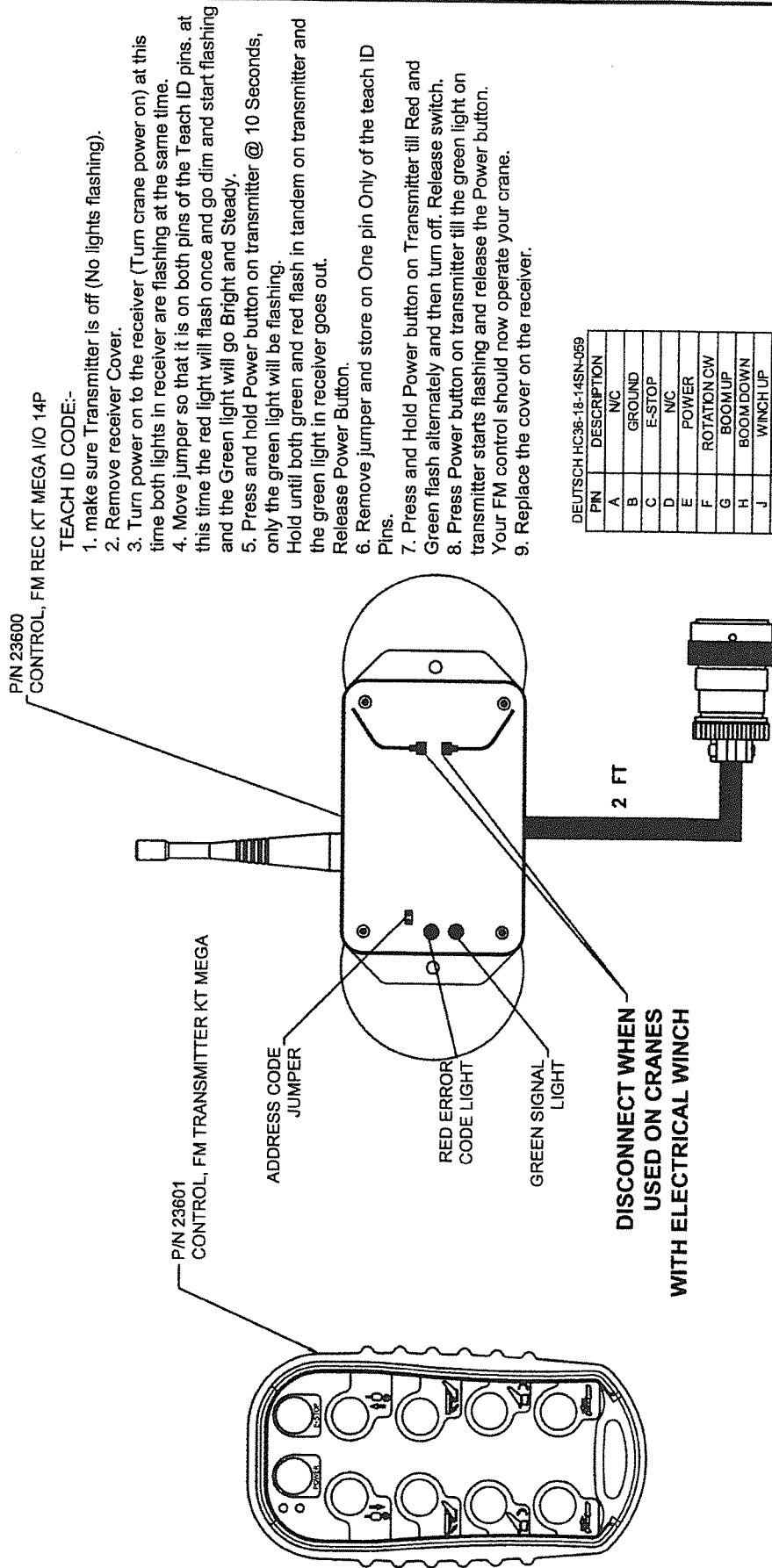

**TEACH ID CODE:-**

1. make sure Transmitter is off (No lights flashing).
2. Remove receiver Cover.
3. Turn power on to the receiver (Turn crane power on) at this time both lights in receiver are flashing at the same time.
4. Move jumper so that it is on both pins of the Teach ID pins. at this time the red light will flash once and go dim and start flashing and the Green light will go Bright and Steady.
5. Press and hold Power button on transmitter @ 10 Seconds, only the green light will be flashing.
6. Hold until both green and red flash in tandem on transmitter and the green light in receiver goes out.
7. Release Power Button.
8. Remove jumper and store on One pin Only of the teach ID Pins.
9. Press and Hold Power button on Transmitter till Red and Green flash alternately and then turn off. Release switch.
10. Press Power button on transmitter till the green light on transmitter starts flashing and release the Power light on Your FM control should now operate your crane.
11. Replace the cover on the receiver.

DEUTSCH HC36-16-14SN-059

FIN	DESCRIPTION
A	N/C
B	GROUND
C	E-STOP
D	N/C
E	POWER
F	ROTATION CW
G	BOOM UP
H	BOOM DOWN
J	WINCH UP
K	PUMP
L	ROTATION CCW
M	BOOM OUT
N	BOOM IN
P	WINCH DOWN

Houston TX  
(713)-688-5533  
www.liftmoore.com

**CONTROL, FM ASSY KT MEGA ELE.**  
TRANS./RECIEVER PRO. SET

DRAWING NO.  
**23821-C**

DRWN BY: JE

DATE: 12/28/10

THIS DRAWING INTENTIONALLY LEFT BLANK

FOR FUTURE ADDITIONS

OR

A PART OR FEATURE IS NOT APPLICABLE TO THIS CRANE

DRAWING NO.

DRWN BY:

DATE:

Houston TX  
(713)-688-5533  
www.liftmoore.com

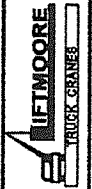

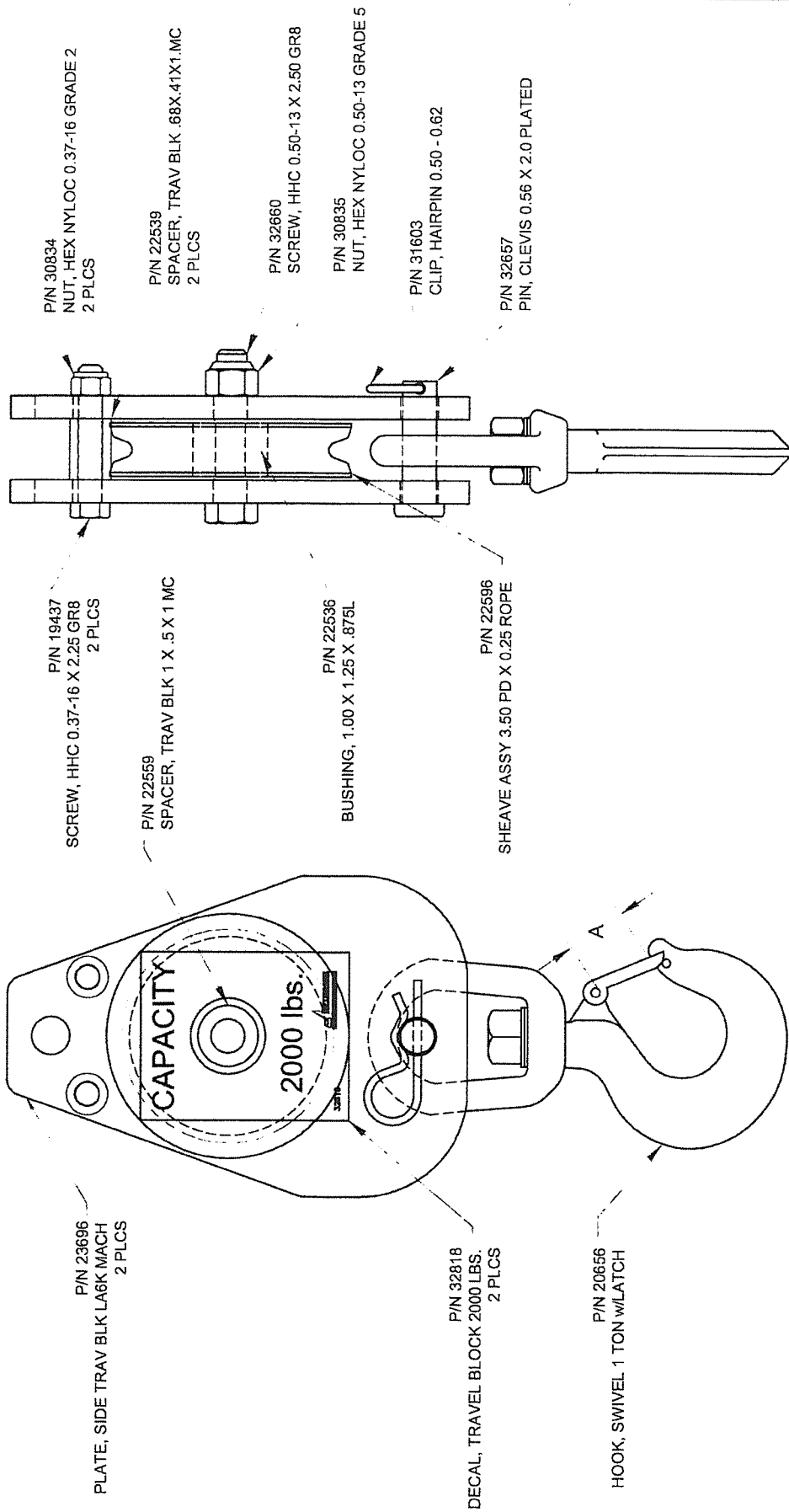

Houston TX (713)-688-5533 www.lifmoore.com	DRWN BY: KSP	BLOCK, TRAV ASSY 2.0K LBS/4.0D 2000Lbs; 0.25" ROPE; LA6K	DRAWING NO. <b>23697-A</b>
	DATE: 4/22/10		



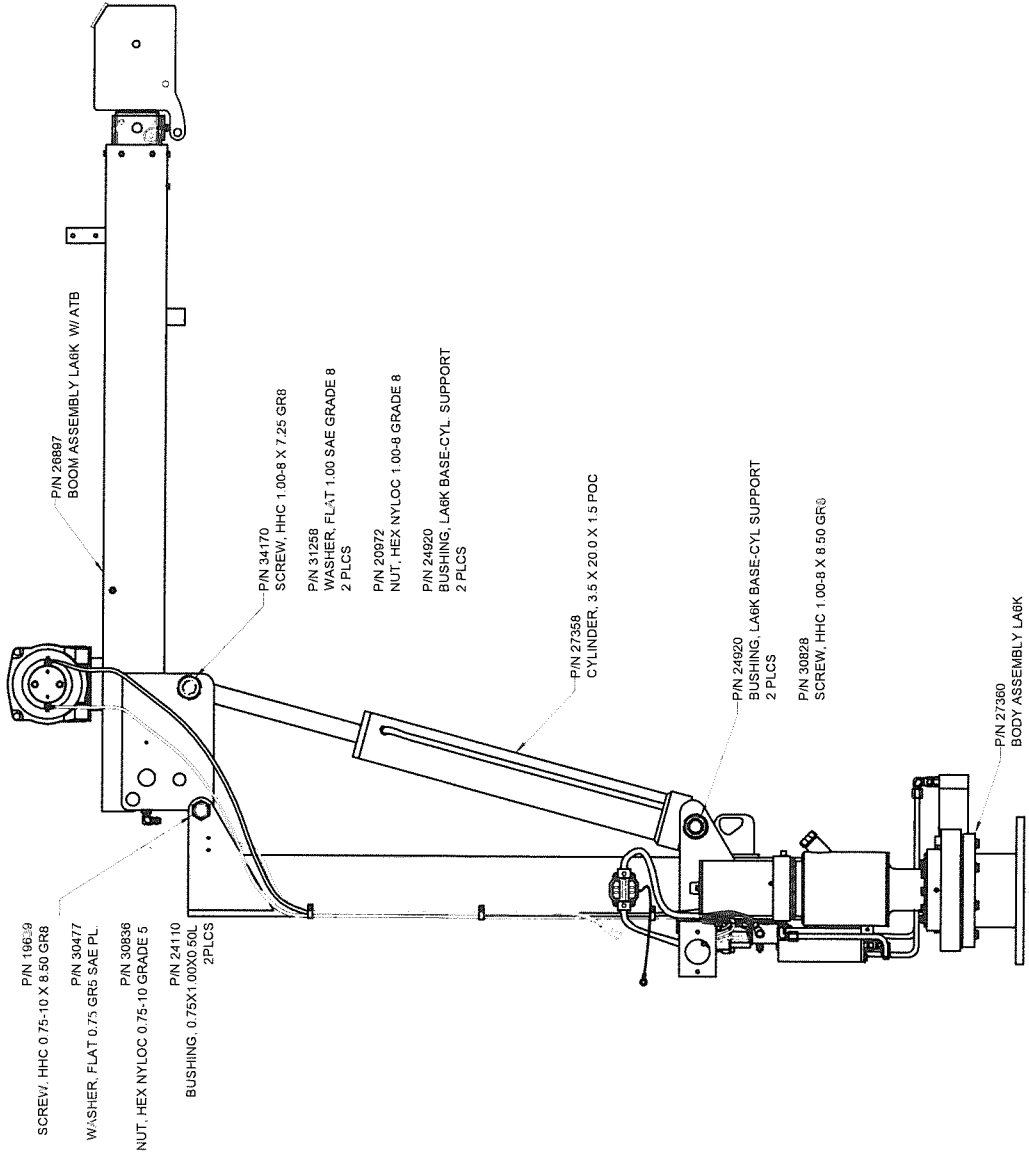

Houston TX  
 (713)-688-5533  
 www.lifmoore.com



DRWN BY: AA  
 DATE: 05/28/15

**BOOM-BODY ASSY LA6K EX-11**  
 BAIL ATB, D RING ON PEDESTAL, 3.08 ROTATION MOTOR

DRAWING NO.  
**27361-0**





BY: AA  
DATE: 05/28/15

BODY ASSEMBLY LA6K  
D RING ON PEDESTAL

DOCUMENT NO.  
27360-A

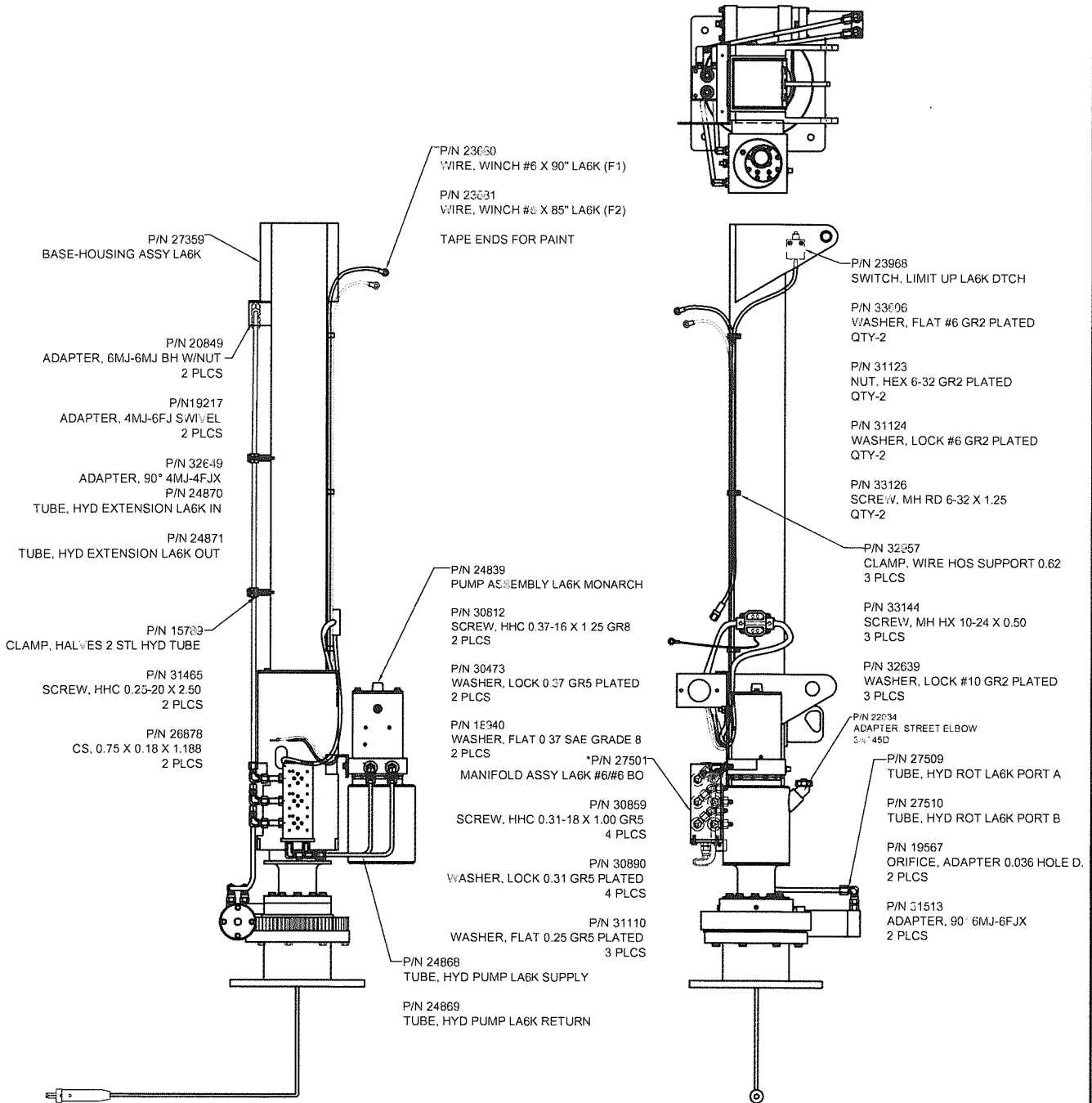

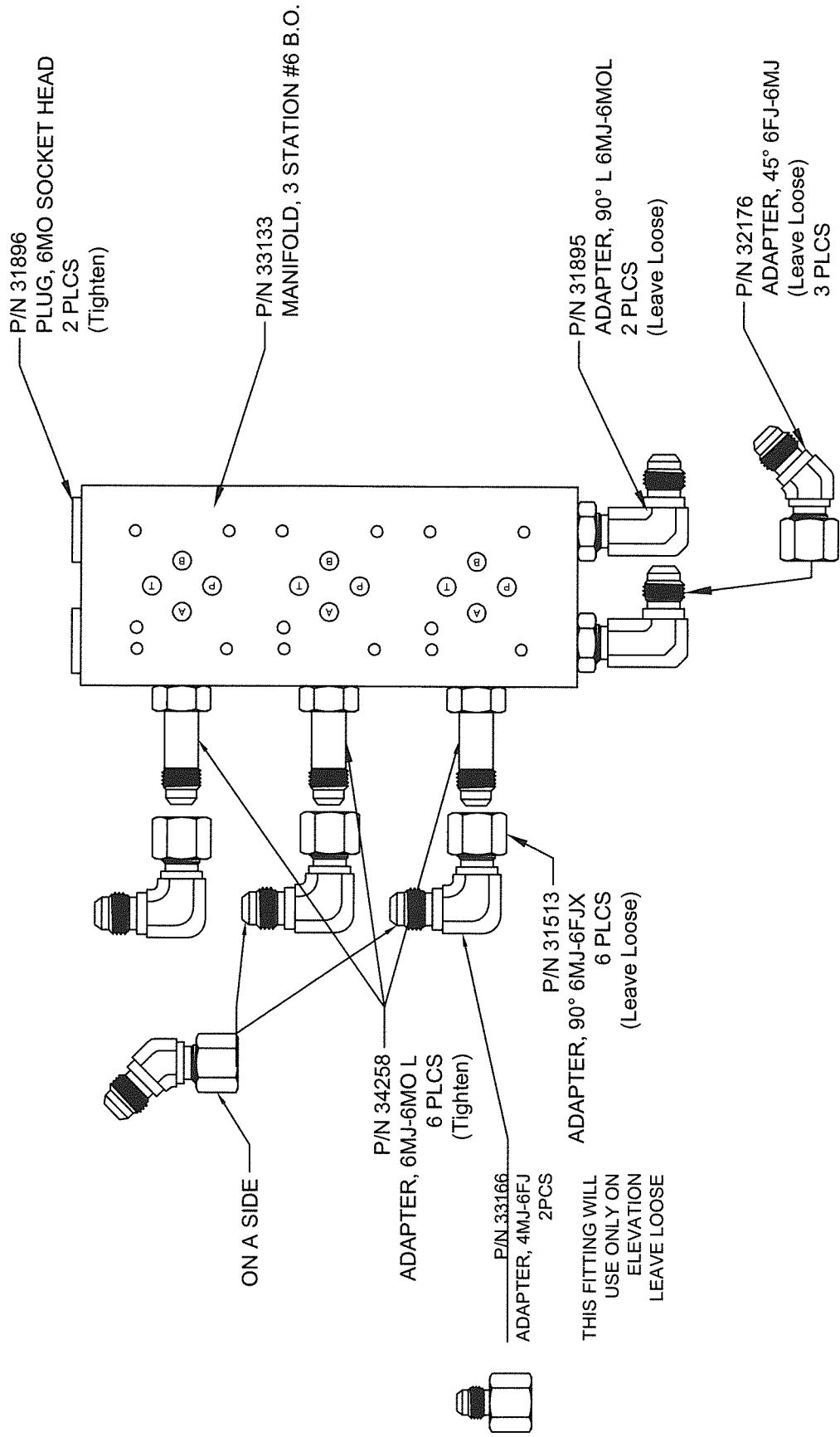

DRAWING NO.  
**27501-0**

**MANIFOLD ASSY LA6K #6/#6 BO**  
 LA6K / NEW ROTATION

DRWN BY: AA  
 DATE: 08/28/15

Houston TX  
 (713)-688-5533  
 www.liftmoore.com

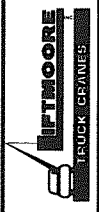



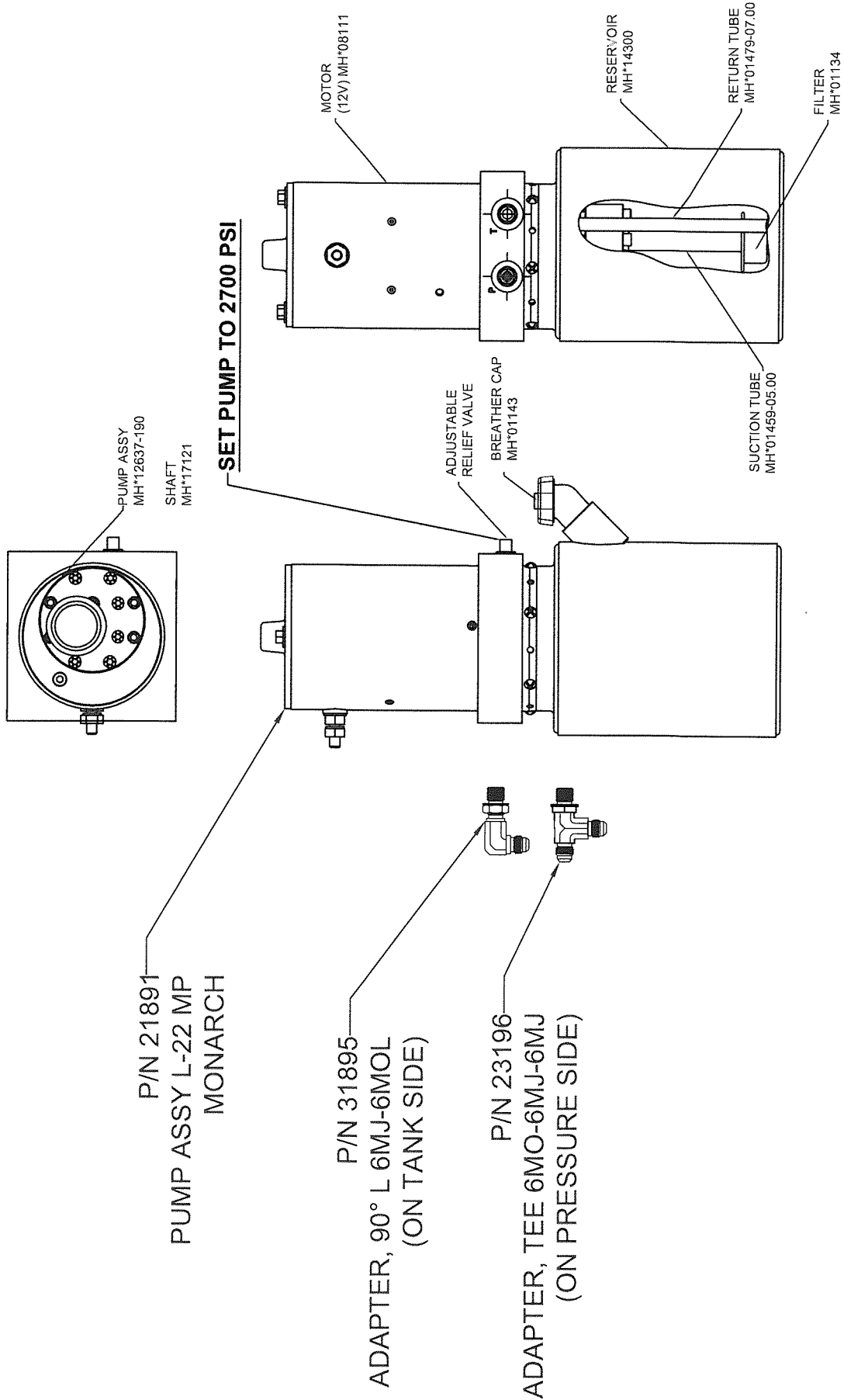

DRAWING NO.  
**24839-A**

**PUMP ASSY LA6K MONARCK**  
D RING ON PEDESTAL

DRWN BY: AA  
DATE: 1/30/12

Houston TX  
(713)-688-5533  
www.lifmoortc.com



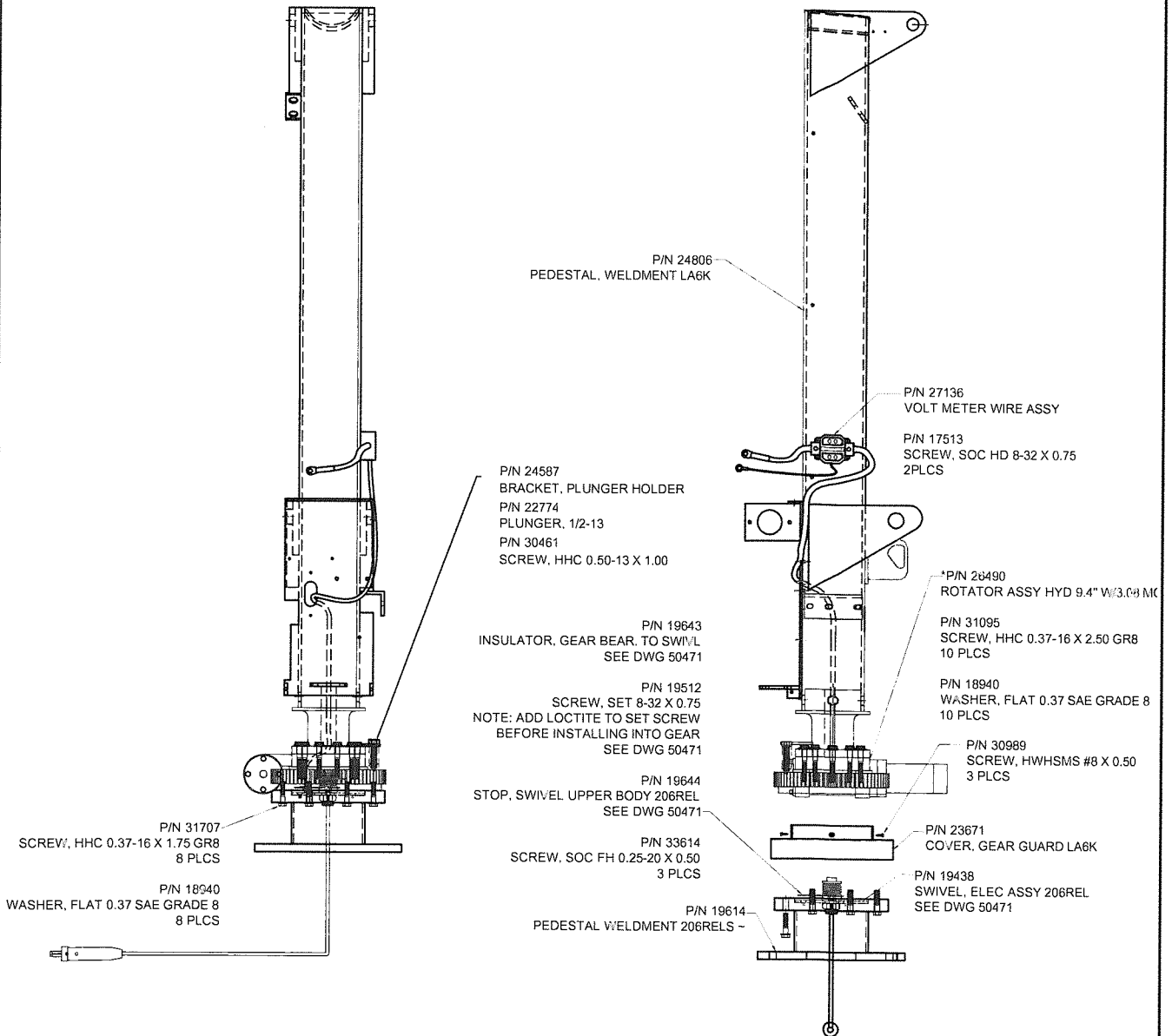
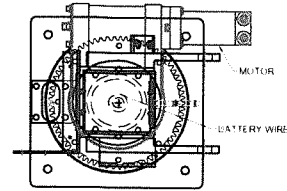

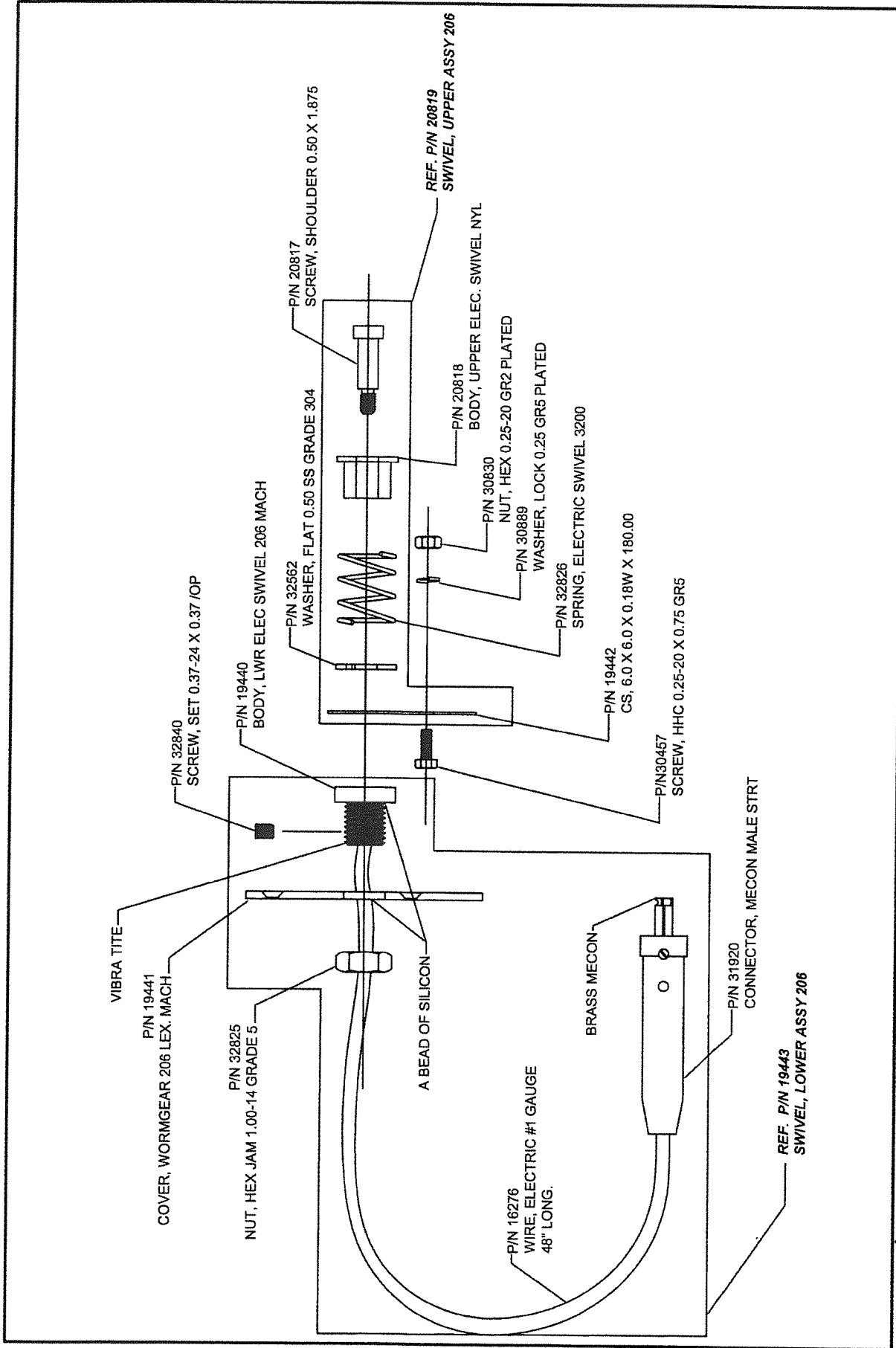

	Houston TX (713)-688-5533 www.liftmoore.com	DRWN BY: JC DATE: 4/1/08	DRAWING NO. <b>19438-B</b>
	<b>ELECTRIC SWIVEL</b> 206 & LA6K		

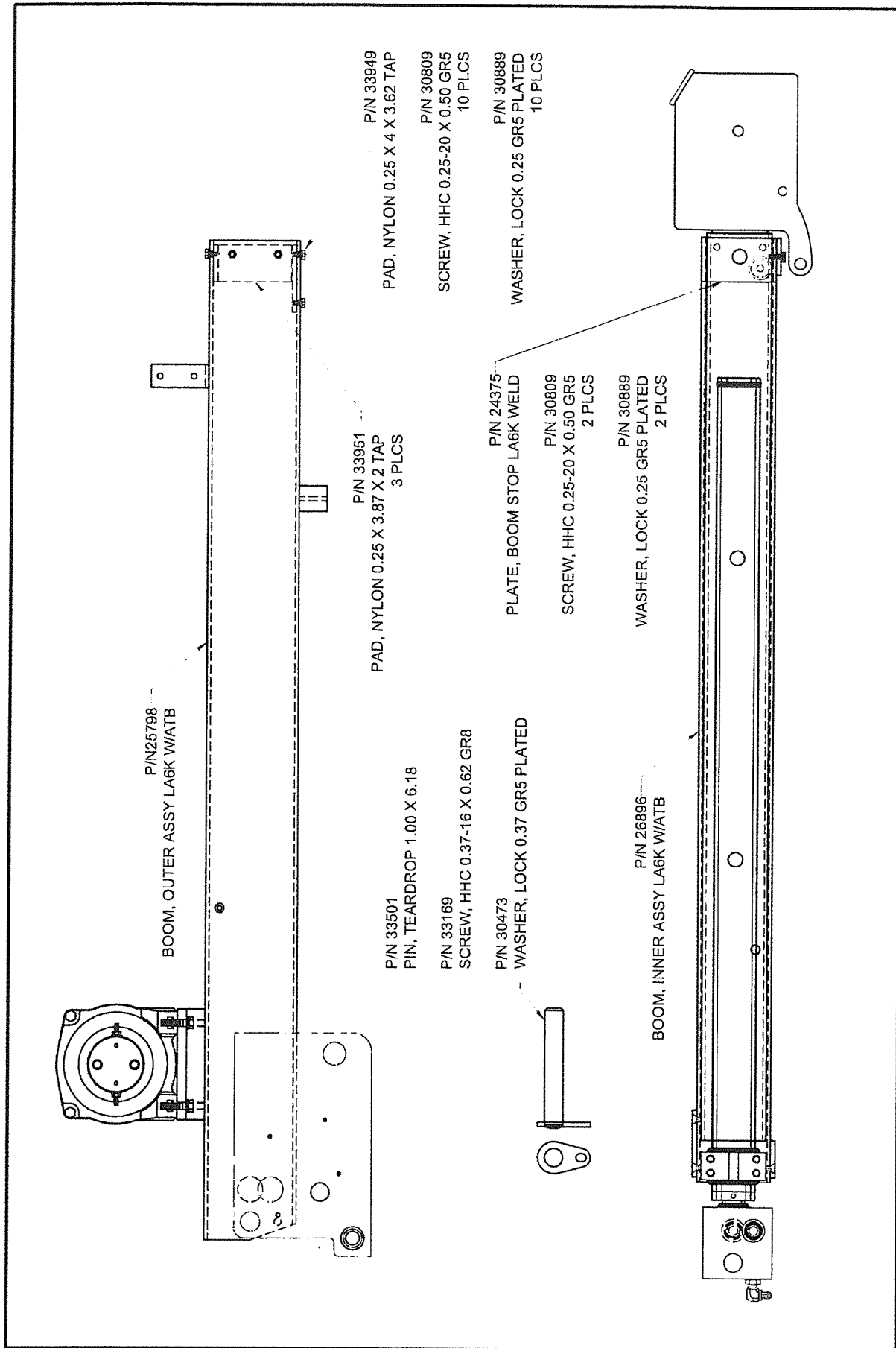

Houston TX (713)-688-5533 www.liftmoore.com	DRN BY: AA	DRAWING NO. <b>26897-0</b>
	DATE: 12/22/14	
<b>BOOM ASSEMBLY LA6K W/ATB</b> BAIL ATB, D RING ON PEDESAL		





**WINCH DC1200 12VDC P/N 22289**

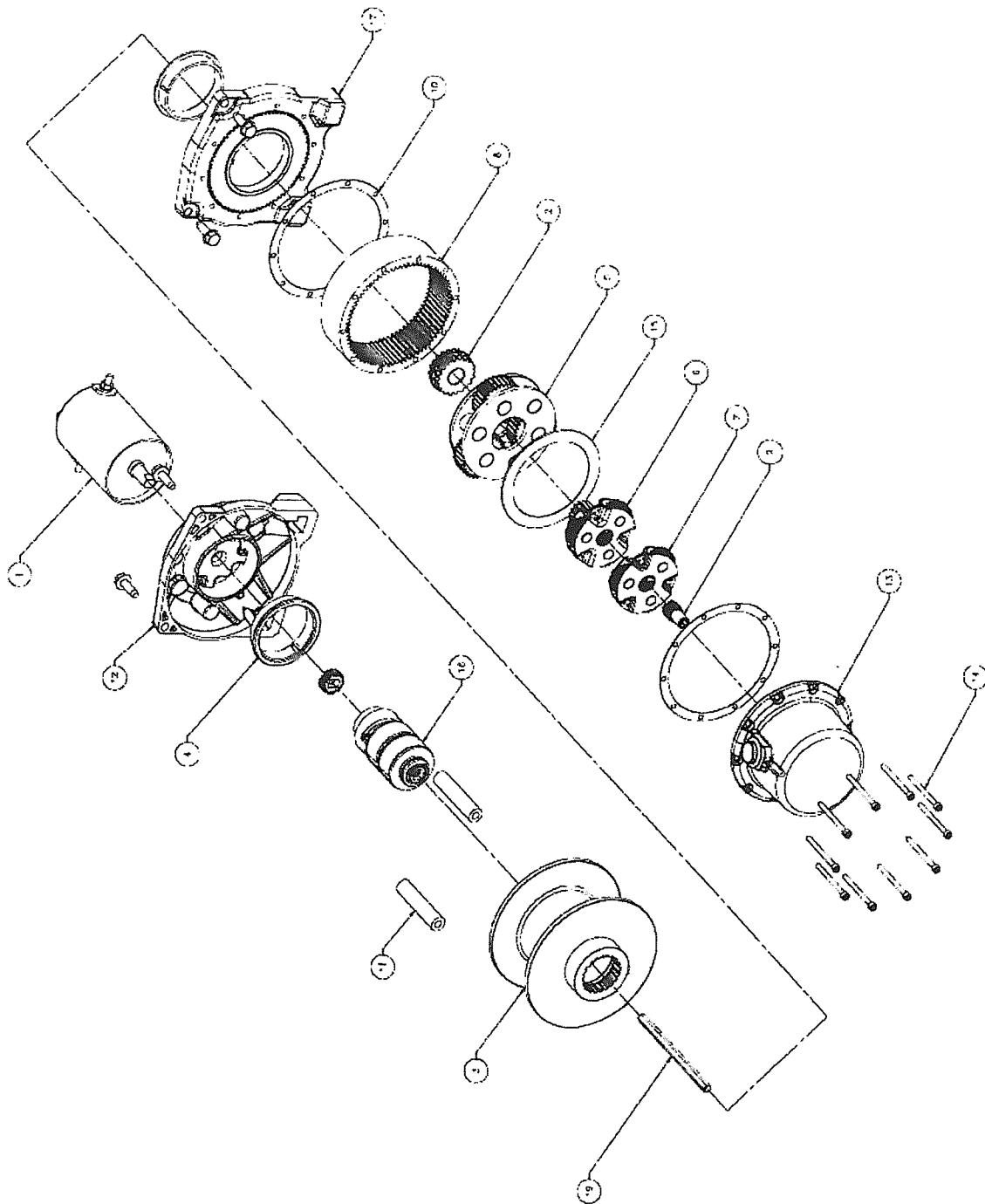

22289-B  
05/14/15

HOUSTON, TEXAS  
FAX: (800) 824-5559 (USA & Canada)  
FAX: (713) 688-6324  
PHONE: (713) 688-5533  
[www.liftmoore.com](http://www.liftmoore.com)

## SERVICE PARTS LIST: DC1200 HOIST-12V P/N 22289

ITEM REFERENCE	ITEM / KIT No.
1. (MTO)KIT, SVC, MOTOR, BOSCH, Z3500	WI*74853
2. (MTO)S/P SPLINED DRIVE, MIDRANGE	WI*14584
3. DRUM, DC1200, 3.5 DIA.	WI*39821
4. BUSHING DRUM NYLON	WI* 13831
5. CARRIER (PH) ASSY, STAGE 3	WI*28432
6. CARRIER (PH) ASSY, STAGE 2	WI*28431 (WI*34342)
7. CARRIER (PH) ASSY, STAGE 1	WI*28430 (WI*34339)
8. RING GEAR, ARG 75 TOOTH	WI*25308
9. GEAR, SUN, 12 TOOTH, STAGE 1	WI*13874
10. HOUSING, GASKET	WI*13848
11. SVC KIT TIE ROD, ALUM, 0.625 X 2.92	WI*85577
12. SVC KIT DRUM SUPPORT MACHINED DC500 24	WI*85574
13. SVC KIT END HOUSING SUBASSY, CLUTCH PL	WI*85583
14. CPSCR-#10-24 X 2-1/4-HEX SOCKET HEAD-PI	WI*13850
15. WASHER, THRUST, NYLON, MIDRANGE	WI*13826
16. (MTO)S/P BREAK, 2.13 ELECTRIC, NON-BIASED	WI*63548
17. (MTO)S/P DRUM SUPPORT, GEAR END	WI*25986
18. PARTS PACK, (PH) DC2000 HOIST	WI*60049
19. (HEX) SHAFT (PH) DRIVE, 5/16 X 5.5	WI*61844



22289-B  
05/14/15

HOUSTON, TEXAS  
FAX: (800) 824-5559 (USA & Canada)  
FAX: (713) 688-6324  
PHONE: (713) 688-5533  
[www.liftmoore.com](http://www.liftmoore.com)





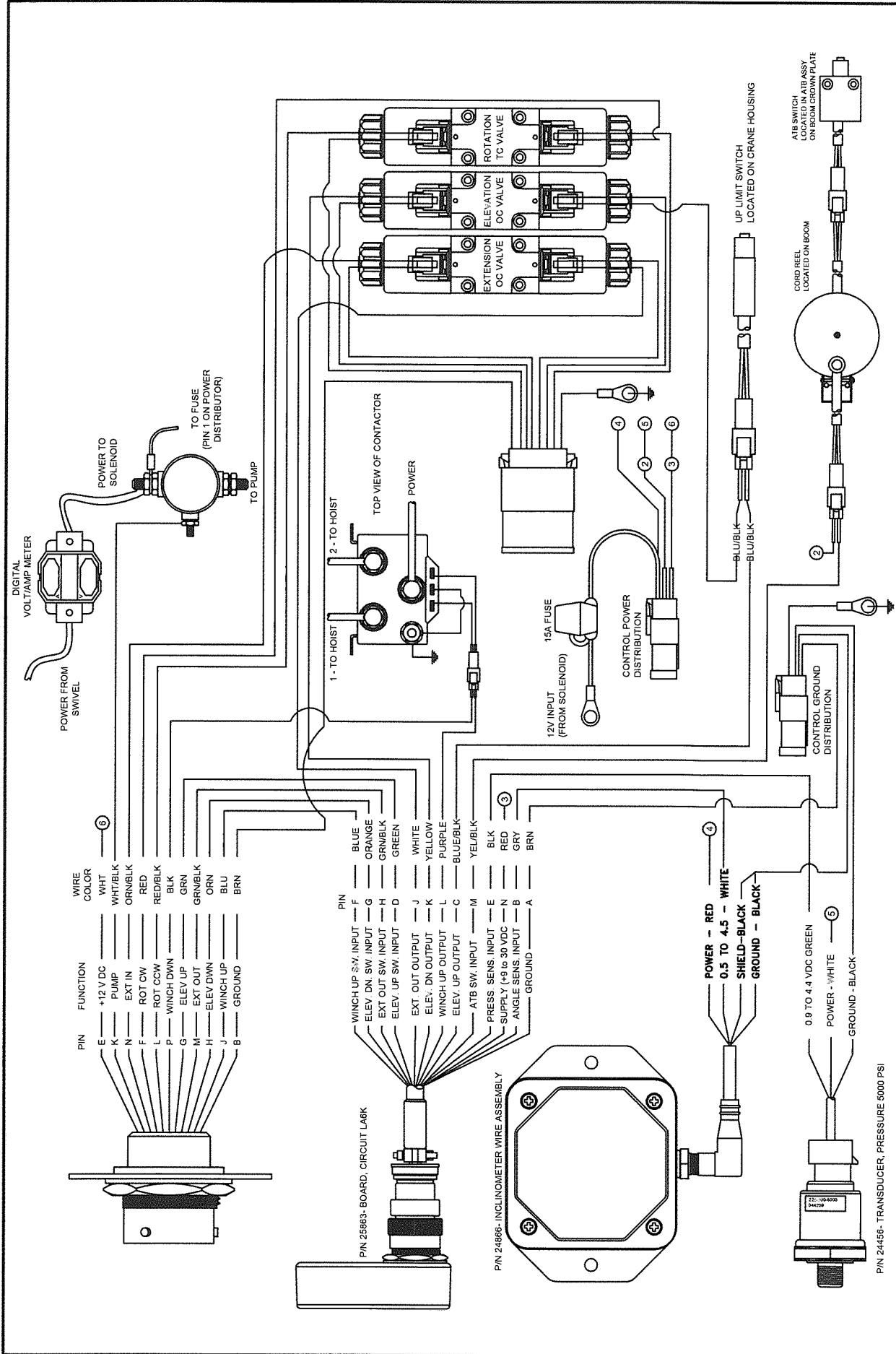

DRWING NO. 50871-A

SCHEM, CRANE ELEC LA6K  
W/ATB, VOLTMETER

DRWN BY: AA  
DATE: 06/19/15

Houston TX  
(713)-688-5533  
www.iftmoore.com

IFTMOORE  
TRUCK CRANES

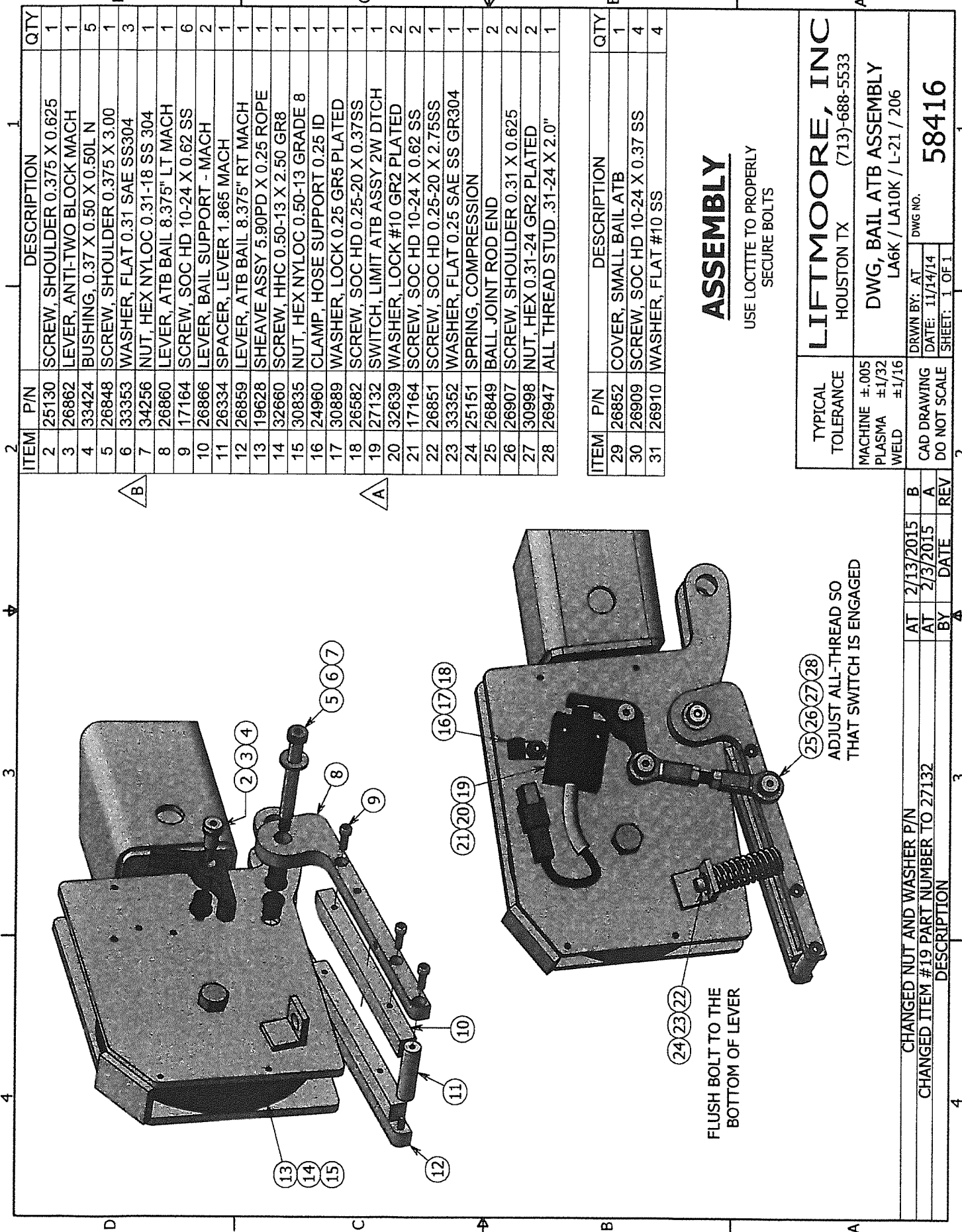

# ASSEMBLY

USE LOCTITE TO PROPERLY  
SECURE BOLTS

ITEM	P/N	DESCRIPTION	QTY
2	25130	SCREW, SHOULDER 0.375 X 0.625	1
3	26862	LEVER, ANTI-TWO BLOCK MACH	1
4	33424	BUSHING, 0.37 X 0.50 X 0.50L N	5
5	26848	SCREW, SHOULDER 0.375 X 3.00	1
6	33353	WASHER, FLAT 0.31 SAE SS304	3
7	34256	NUT, HEX NYLOC 0.31-18 SS 304	1
8	26860	LEVER, ATB BAIL 8.375" LT MACH	1
9	17164	SCREW, SOC HD 10-24 X 0.62 SS	6
10	26866	LEVER, BAIL SUPPORT - MACH	2
11	26334	SPACER, LEVER 1.865 MACH	1
12	26859	LEVER, ATB BAIL 8.375" RT MACH	1
13	19628	SHEAVE ASSY 5.90PD X 0.25 ROPE	1
14	32660	SCREW, HHC 0.50-13 X 2.50 GR8	1
15	30835	NUT, HEX NYLOC 0.50-13 GRADE 8	1
16	24960	CLAMP, HOSE SUPPORT 0.25 ID	1
17	30889	WASHER, LOCK 0.25 GR5 PLATED	1
18	26582	SCREW, SOC HD 0.25-20 X 0.37SS	1
19	27132	SWITCH, LIMIT ATB ASSY 2W DTCH	1
20	32639	WASHER, LOCK #10 GR2 PLATED	2
21	17164	SCREW, SOC HD 10-24 X 0.62 SS	2
22	26851	SCREW, SOC HD 0.25-20 X 2.75SS	1
23	33352	WASHER, FLAT 0.25 SAE SS GR304	1
24	25151	SPRING, COMPRESSION	1
25	26849	BALL JOINT ROD END	2
26	26907	SCREW, SHOULDER 0.31 X 0.625	2
27	30998	NUT, HEX 0.31-24 GR2 PLATED	2
28	26947	ALL THREAD STUD .31-24 X 2.0"	1

ITEM	P/N	DESCRIPTION	QTY
29	26852	COVER, SMALL BAIL ATB	1
30	26909	SCREW, SOC HD 10-24 X 0.37 SS	4
31	26910	WASHER, FLAT #10 SS	4

TYPICAL TOLERANCE	MACHINE ±.005 PLASMA ±1/32 WELD ±1/16	DRWN BY: AT DATE: 11/14/14 SHEET: 1 OF 1
<b>LIFTMOORE, INC</b> HOUSTON TX (713)-688-5533		
DWG, BAIL ATB ASSEMBLY LA6K / LA10K / L-21 / 206		
DO NOT SCALE		DWG NO. <b>58416</b>

CHANGED NUT AND WASHER P/N	AT	2/13/2015	B
CHANGED ITEM #19 PART NUMBER TO 27132	AT	2/3/2015	A
DESCRIPTION	BY	DATE	REV

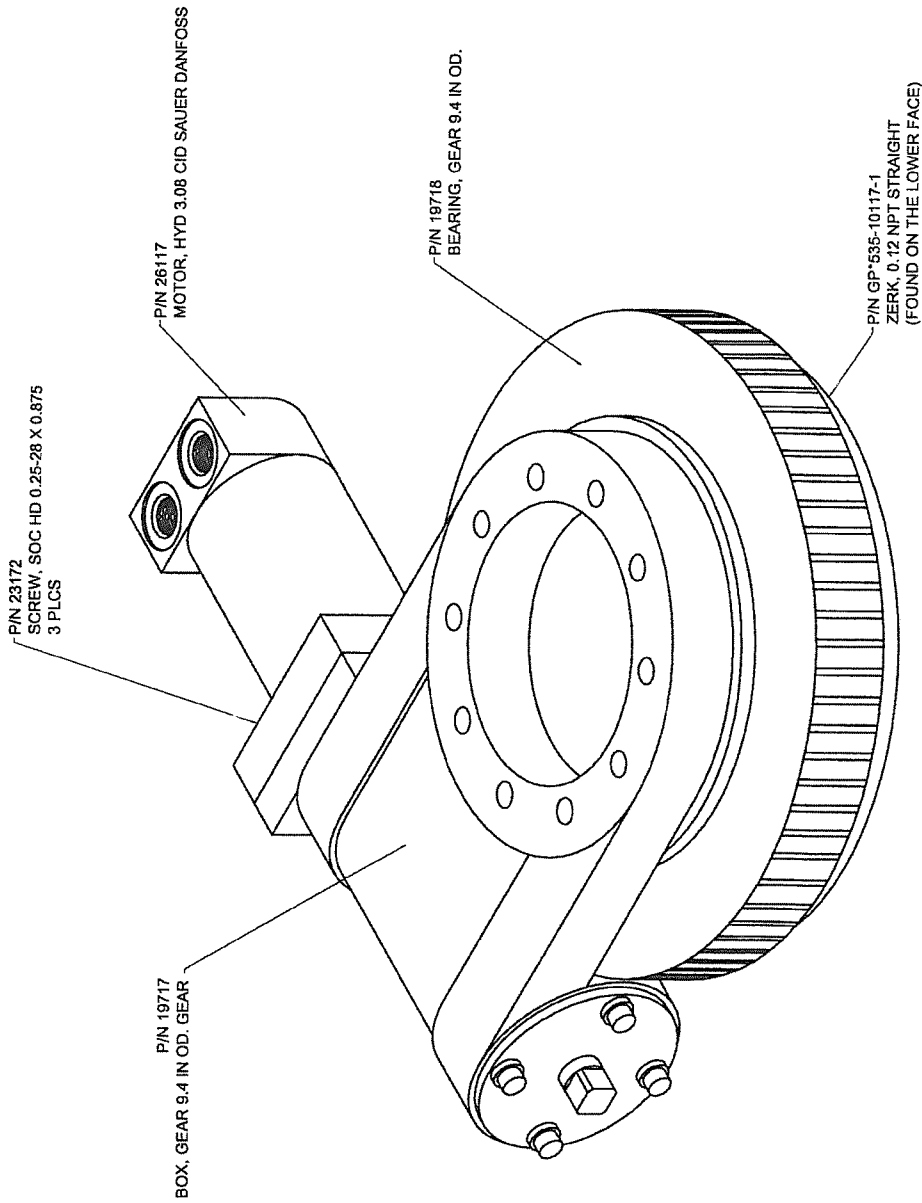

DRAWING NO. 26490-0

ROTATOR, ASSY HYD 9.4 LA6K  
BEARING, WORM, AND 3.08 MOTOR

DRWN BY: JE

DATE: 4/15/14

Houston TX  
(713)-688-5533  
www.lifmoore.com



**SPECIFICATIONS:**

**GENERAL**

DESCRIPTION: SOLID STATE INCLINOMETER FOR MEASUREMENT OF THE INCLINATION OR ANGLE OF A SLOPE WITH RESPECT TO GRAVITY.

RANGE: -30° TO +90°

OUTPUT: 0.5 TO 4.5VDC

RESOLUTION: .25°

ACCURACY: ±0.3°

MINIMUM INPUT IMPEDANCE: 10K OHM

**ELECTRICAL**

SUPPLY VOLTAGE: 9 TO 35 VDC

SUPPLY CURRENT: 29mA

REVERSE POLARITY PROTECTION: PROTECTED

OVER-VOLTAGE PROTECTION: PROTECTED

**ENVIRONMENTAL**

OPERATING TEMPERATURE: -40 TO +85 DEG. C

STORAGE TEMPERATURE: -50 TO +100 DEG. C

PROTECTION: IP67

**ELECTRICAL CONNECTION**

A = POWER (9 TO 35 VDC)

B = 0.5V TO 4.5V

C = GROUND

D = NO CONNECT

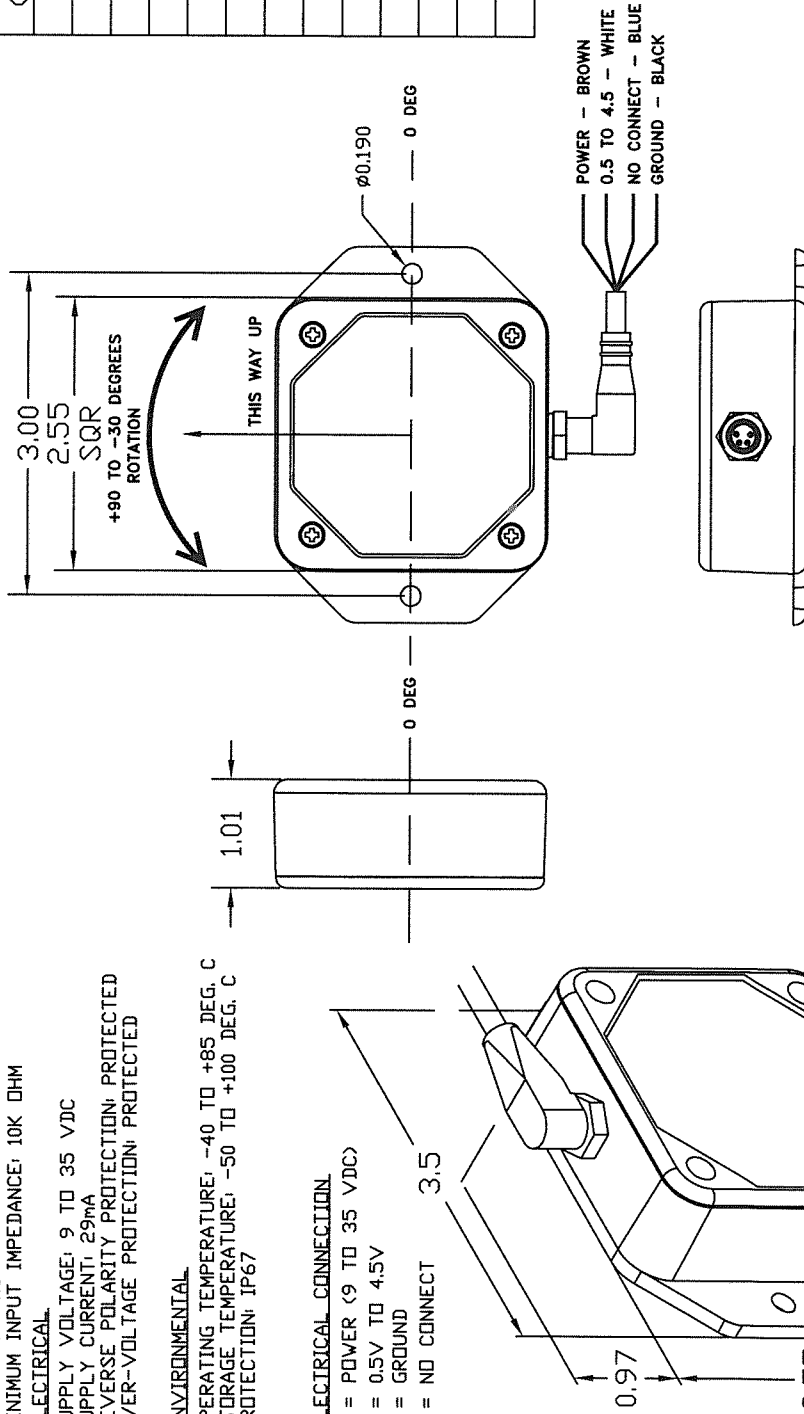

OUTPUT CHARACTERISTICS	
MAX ROTATION	90.00
MIN ROTATION	-30.00
ROTATION (DEGREES)	OUTPUT (VOLTS)
-30	0.50
-20	0.83
-10	1.17
0	1.50
10	1.83
20	2.17
30	2.50
40	2.83
50	3.17
60	3.50
70	3.83
80	4.17
90	4.50

Houston TX  
(713)-688-5533  
www.liftmoore.com

DRWN BY: JE

DATE: 8/6/15

**INCLINOMETER, 120 DEGREE**

DRAWING NO.

**24457-A**

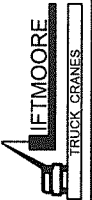

# OUTPUT CHARACTERISTICS

(FULL RANGE:5000) (LOAD RESISTER 220)

PRESSURE	OUTPUT (mA)	OUTPUT (V)
0	4	0.88
312.50	5	1.10
625.00	6	1.32
937.50	7	1.54
1250.00	8	1.76
1562.50	9	1.98
1875.00	10	2.20
2187.50	11	2.42
2500.00	12	2.64
2812.50	13	2.86
3125.00	14	3.08
3437.50	15	3.30
3750.00	16	3.52
4062.50	17	3.74
4375.00	18	3.96
4687.50	19	4.18
5000.00	20	4.40

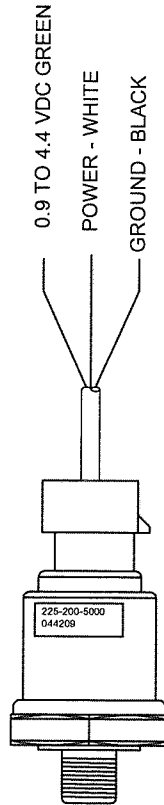

Houston TX  
(713)-688-5533  
www.liftmoore.com



DRWN BY: AA  
DATE: 2/10/12

TRANSDUCER, PRESSURE 5000 PSI  
TRANSDUCER

DRAWING NO.  
24456-A

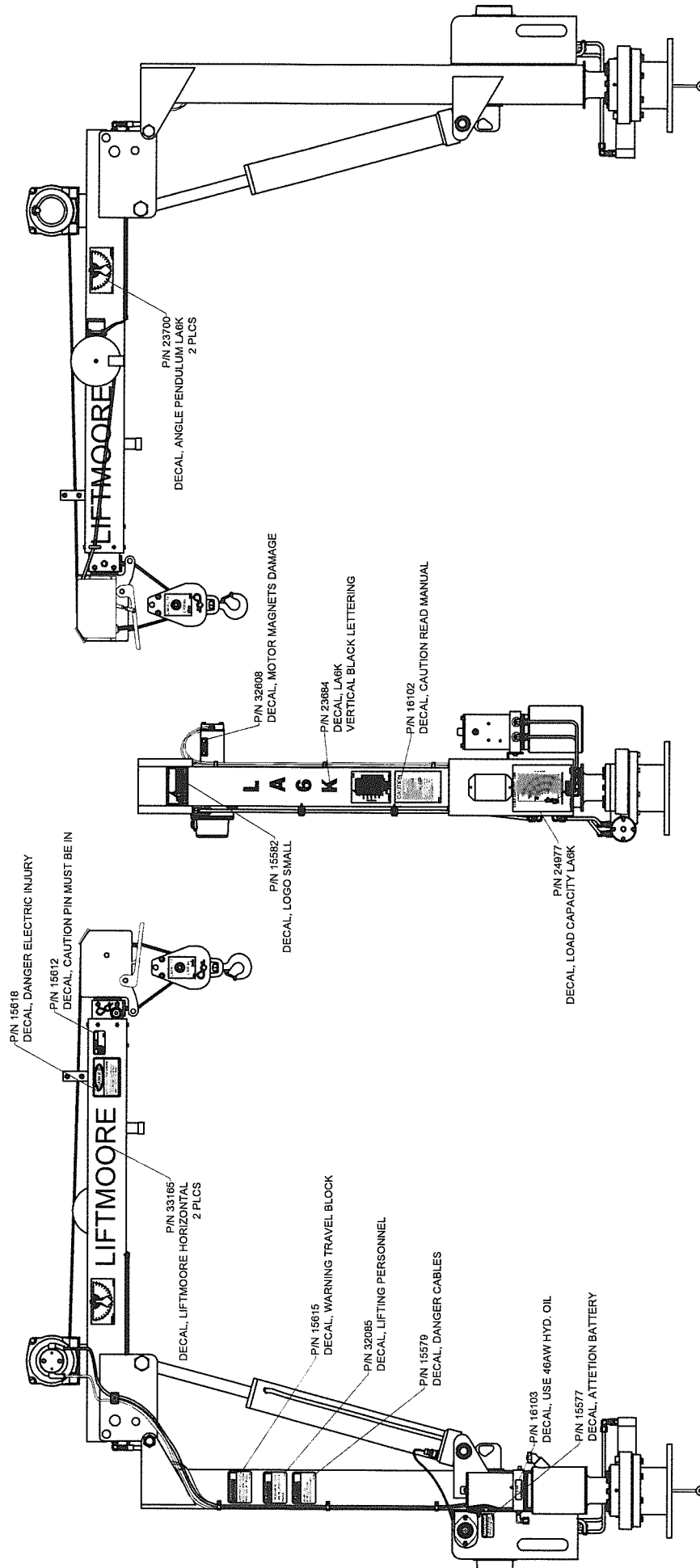

DRAWING NO.  
**58415-A**

**DIAGRAM, DECAL LA6K EX-11**  
ATB

DRWN BY: JE  
DATE: 9/12/14

Houston TX  
(713)-688-5533  
www.liftmoore.com



## **LIFTMOORE LIMITED WARRANTY**

### Parts and Structural

Liftmoore, Inc. warrants each LIFTMOORE crane to be free from defects in materials and workmanship for twelve (12) months from the date of delivery to the original customer. Under the terms of this warranty the crane structural components manufactured by LIFTMOORE, Inc. are warranted for thirty-six (36) months from the date of delivery to the original customer. LIFTMOORE, Inc. will repair or replace, as its sole discretion, any equipment or part that is returned f.o.b. to LIFTMOORE, Inc.'s plant at 7810 Pinemont Drive, Houston, Texas 77040, or to one of its authorized dealers, and is found by LIFTMOORE, Inc. or its authorized dealer to have been defective at the time of original delivery.

The foregoing warranty is the exclusive warranty made by LIFTMOORE, Inc. with respect to its cranes and is in lieu of all other warranties. ANY AND ALL OTHER WARRANTIES, EXPRESS OR IMPLIED, INCLUDING ANY WARRANTY OF MERCHANTABILITY OR FITNESS OF ANY CRANE FOR A PARTICULAR PURPOSE OR OPERATION, ARE HERBY EXPRESSLY DISCLAIMED.

The foregoing warranty applies only to LIFTMOORE cranes under normal use and service and does not apply in the event of damage caused by repair or alteration or damage during shipment, accident, negligence, overloading, or misuse, including operator's failure to follow any of the instructions issued with the crane.

This warranty is limited to the original purchaser and is not assignable. In order to submit a claim, the original purchaser must provide a copy of the original invoice for the crane in question within twelve (12) months following the delivery date and within 30 days from the date of repair.

The warranty applies only when the LIFTMOORE crane is used for commercial purposes and does not cover any purchase for use for personal, family or household purposes.

**LIMITATION OF LIABILITY:** LIFTMOORE, Inc.'s liability for any losses or damages resulting from any cause whatsoever, including LIFTMOORE, Inc.'s NEGLIGENCE or from a defective crane irrespective of whether such defects are discoverable or latent, shall in no event exceed the purchase price of the crane to which losses or damages are claimed, or at the election of LIFTMOORE, Inc., the repair or replacement of the defective crane.

In no event shall LIFTMOORE, Inc. be liable for any special, incidental, or consequential damages, including commercial losses or costs of any kind sustained by purchaser or any other person or for any damages for which purchaser may be liable to other persons by reason of any defect in any LIFTMOORE crane or any part thereof.

LIFTMOORE, Inc. reserves the right to make changes in design or construction of its cranes at any time without obligating itself to make such changes on cranes previously manufactured.

No agent, employee, or representative of LIFTMOORE, Inc. has authority to amend or modify the foregoing warranty or to bind LIFTMOORE, Inc. by any other warranty, guaranty, or assumption of liability.

In the event any provision of this warranty is for any reason held ineffective, the remaining provisions shall remain in full force and effect.

Some states do not allow limitations on how long an implied warranty lasts or the exclusion or limitation of incidental or consequential damages, so the above limitations and exclusions may not apply to you. This warranty gives you specific legal rights, and you may also have other legal rights that vary from state to state.



F1442-A  
01/01/2008

HOUSTON, TEXAS  
FAX: (800) 824-5559 (USA & Canada)  
FAX: (713) 688-6324  
PHONE: (713) 688-5533  
[www.liftmoore.com](http://www.liftmoore.com)