

TABLE OF CONTENTS

USERS MANUAL P/N 26970

206REL/RELS

W/DTCH VALVE & ATB

SECTION I

GENERAL OPERATION, INSPECTION, AND MAINTENANCE

CRANE SAFETY RULES.....	F1122-B	1-1
INTRODUCTION.....	F1111-D	1-3
OPERATING RESTRICTIONS	F1449-0.....	1-4
OPERATING PRACTICES.....	F1449-0.....	1-4
INSPECTION AND MAINTENANCE.....	F1113-D	1-7
MONTHLY INSPECTION REPORT.....	F1448-0.....	1-9

SECTION II

CRANE SYSTEMS AND TROUBLESHOOTING

206REL PENDANT CONTROL SYSTEM.....	F1172-0.....	2-1
HYDRAULIC SYSTEM FOR ELECTRIC CRANE	F1145-C	2-3
TROUBLESHOOTING ELECTRIC CRANE	F1173-0.....	2-5

SECTION III

CRANE SPECIFICATIONS

LIFTING CAPACITIES	F1450-D.....	3-1
POWER FUNCTIONS AND SPEEDS	F1450-D.....	3-1
LIFTING CAPACITIES - 206W	F1450-D.....	3-2
POWER FUNCTIONS AND SPEEDS - 206W	F1450-D.....	3-2
BOLT AND LUBRICATION SPECS	F1450-D.....	3-3

SECTION IV

PARTS

BOX PARTS LIST.....	F2228-0.....	4-1
CRANE ASSEMBLY	DWG.26969-0	4-2
PENDANT CONTROL.....	DWG.19425-E.....	4-3
TRAVEL BLOCK ASSEMBLY	DWG.22599-A	4-4
BOOM-BODY ASSEMBLY	DWG.26968-0	4-5
ELEVATION CYLINDER ASSEMBLY	DWG.19448-D	4-6
BODY ASSEMBLY	DWG.25575-A	4-7
MANIFOLD ASSEMBLY.....	DWG.23169-0	4-8
HYDRAULIC PUMP.....	DWG.21589-A	4-9
BASE-HOUSING ASSEMBLY	DWG.20116-F	4-10
GEAR BEARING ASSEMBLY	DWG.19430-B	4-11



TABLE OF CONTENTS

USERS MANUAL P/N 26970

206REL/RELS

W/DTCH VALVE & ATB

ELECTRICAL SWIVEL	DWG.50471-F	4-12
BOOM ASSEMBLY – 206	DWG.26967-0	4-13
BOOM ASSEMBLY – 206W	DWG.26973-0	4-14
WINCH 1200.....	DWG.22289-B	4-15
WINCH 1200 PARTS LIST.....	DWG.22289-B	4-16
PEDESTAL, L-21RF/22AR VAR. HT.....	DWG.17104-I.....	4-17
PLATE, BASE - FLANGE MNT. MACH.....	DWG.17101-A	4-18
ELECTRICAL SCHEMATIC.....	DWG.50833-0	4-19
DECAL DIAGRAM	DWG.58284-B	4-20
ATB ASSEMBLY	DWG.58416-0	4-21
WARRANTY.....	F1442-A	



CRANE SAFETY RULES

CAUTION!

1. READ AND UNDERSTAND OPERATOR'S MANUAL.
2. INSPECT VEHICLE AND CRANE, INCLUDING ITS OPERATION, BEFORE DAILY USE.
3. USE THIS EQUIPMENT ONLY ON SOLID LEVEL GROUND WITH OUTRIGGERS OR JACKSTANDS PROPERLY SET.
4. BEFORE OPERATING THE CRANE REFER TO MAXIMUM LOAD CHART ON CRANE FOR OPERATING LOAD LIMITS.
5. BE SURE LOAD BEING LIFTED IS WITHIN SAFE WINCH CAPACITY AS WELL AS SAFE CRANE CAPACITY. MULTI-PART LINE OPERATION IS REQUIRED WHEN SINGLE LINE LOAD CAPACITY OF WINCH IS EXCEEDED.
6. DO NOT OPERATE, WALK, OR STAND UNDER THE BOOM OR ANY SUSPENDED LOAD.
7. ALWAYS PAY OUT LOAD LINE BEFORE EXTENDING BOOM. WIRE ROPE DAMAGE AND / OR BREAKAGE MAY OCCUR.
8. BOOM MUST BE IN ITS REST BEFORE MOVING VEHICLE.
9. BOOM TIP MUST BE DIRECTLY OVER THE LOAD BEFORE ANY LIFTING IS STARTED. DO NOT DRAG LOADS WITH THIS CRANE.
10. MAINTAIN THIS CRANE AS REQUIRED IN THE OWNER'S MANUAL.
11. DO NOT ALLOW PERSONNEL TO RIDE ON THE LOAD LINE, LOAD, OR BOOM OF THIS CRANE.
12. IT IS UNLAWFUL TO OPERATE THIS EQUIPMENT WITHIN TEN FEET OF HIGH VOLTAGE LINE



F1122-B
5/12/08

HOUSTON, TEXAS
FAX: (800) 824-5559 (USA & Canada)
FAX: (713) 688-6324
PHONE: (713) 688-5533
www.liftmoore.com

THIS PAGE INTENTIONALLY LEFT BLANK



F1122-B
5/12/08

HOUSTON, TEXAS
FAX: (800) 824-5559 (USA & Canada)
FAX: (713) 688-6324
PHONE: (713) 688-5533
www.liftmoore.com

INTRODUCTION

This crane is a powerful machine designed to lift and move heavy loads. There are many hazards associated with these operations. Liftmoore has designed this crane to be as safe as possible but -

IT IS THE OPERATOR'S RESPONSIBILITY TO PREVENT ACCIDENTS!

This takes pre-planning, attention, and knowledge of basic principles and rules. Even if you have used similar cranes, reading this manual in its entirety will help prevent damage, injury, or even loss of life; benefits well worth the short amount of time it takes to read these pages.

REGULATORY AUTHORITY

Use of this crane is governed by OSHA 29 CFR 1910.180 and may be governed by other federal, state, or local regulations.

IT IS THE OPERATOR'S RESPONSIBILITY TO UNDERSTAND AND COMPLY WITH ALL APPLICABLE REGULATIONS GOVERNING THE OPERATION, INSPECTION, AND MAINTENANCE OF THIS CRANE.

Personnel should be trained, tested, and certified, as recommended by OSHA and ANSI standards, before operating this crane.

USING THIS MANUAL

This manual assumes that the crane is mounted on a typical service body type or similar truck, which is powered by the vehicle electrical or hydraulic system, and is controlled by either the standard pendant control or FM radio control sold by Liftmoore, Inc.

This manual is supplied to provide basic guidelines for the safe use, routine maintenance, and general inspections of this crane.

Laws, regulations, standards, or policies may be more restrictive than this manual. If a conflict exists for any limit or condition, the safest or most prohibitive shall be used. Under no circumstances shall the load, moment, or stability ratings be exceeded.

Pay particular attention to the following:

WARNING! – Draws attention to hazards, conditions, or procedures that if not observed could result in injury or death.

CAUTION! – Draws attention to hazards, conditions, or procedures that if not observed could result in damage to the crane, load, or other equipment. Equipment failure could in turn lead to injury or death.

NOTE! – Draws attention to conditions or procedures that are essential to emphasize.

For questions, interpretations, or to report errors, please contact Liftmoore, Inc, Engineering Dept.



F1111-D
09/30/09

HOUSTON, TEXAS
FAX: (800) 824-5559 (USA & Canada)
FAX: (713) 688-6324
PHONE: (713) 688-5533
www.liftmoore.com

OPERATING PRACTICES

OPERATING RESTRICTIONS

DUTY CYCLE

For Electric Cranes the duty cycle time should be limited to 10%. This is limited by heat buildup in the motors and declining charge in the batteries. (Installing extra batteries near the crane helps keep the voltage at maximum.)

PERSONNEL

LIFTING OR MOVING OF PERSONNEL IS STRICTLY PROHIBITED! This crane was neither designed nor intended to lift personnel. Under no circumstances should anyone be allowed to ride on the crane, line, or load. All non-essential personnel must be kept away when using the crane. The load must never be moved over people, nor must anyone be allowed to pass or stand under a suspended load.

ELECTRICAL LINES

Consult ANSI B30.5 for operating procedures, minimum safe distances, and prohibited zones when working around electrical lines or poles.

When operating near electrical power lines, the crane must be positioned so that the distance from the crane to the lines or poles is equal to or greater than the length of the fully extended boom plus the minimum safe distance required.

All parts of the crane, line, and load must be kept a minimum safe distance from electrical power lines and poles. This distance is 10 feet for electrical lines carrying 50kV or less.

UNDER NO CIRCUMSTANCES SHOULD A CRANE BE OPERATED UNDER ELECTRICAL POWER LINES.

SETUP

POSITION The vehicle must be positioned so that the load is kept as close to the crane base as possible to reduce the moment on the crane. Consideration must be given to starting and ending position as well as firmness and slope of the ground and any obstructions.

OUTRIGGERS The outriggers or jackstands must be firmly set and the vehicle as level as possible. This will reduce the stresses on the rotation drive and keep the load off the vehicle's suspension. Keep in mind that the weight on the vehicle will shift as the crane and load are rotated.

LOAD LIMIT The operator must understand the crane load chart. The operator must ensure that the load is within the load limits over the entire range which it will be moved. Be sure to include the weight of any lifting devices including the travel block.

The load limit chart is attached to the side of the crane to aid the operator.

The boom angle indicator and chart aids the operator in determining the load capacity at various boom angles and extensions. It also gives the load limit at that configuration.

STABILITY The operator is responsible to verify that the truck is stable at any area where the Crane is rotated.

TRAVEL BLOCK The operator must determine if the load is within the single line compatibility of the winch or if a multi-part line configuration is needed.



REEVING Ensure the proper routing of the rope through the sheaves and travel block. The rope must lie in the sheave groove and must not rub against any metal objects.

Ensure the rope is correctly wound on the winch drum. The crane assembly drawing will indicate if the rope must be wound over the top or bottom of the drum. The rope must never contact any part of the winch mounting.

WARNING!

If the winch winding direction is reversed the brake will not work and the load will fall.

ATTACHING THE LOAD

POSITION The boom tip must be moved over the load before lifting so that it will be lifted straight up.

CAUTION!

Never drag a load with the crane. Dragging a load puts very high stresses on the crane for which it was not designed.

ROPE Check the rope condition to ensure it is not frayed or damaged. Ensure that the rope is not kinked and that it does not contact any sharp edges or make any sharp bends.

If using double line configuration, ensure that the lines are not twisted.

CAUTION!

Never wrap the hoist rope around the load! Serious damage to the rope WILL occur.

HOOK Always make sure the load is applied to the throat of the hook. Never use a bent hook.

CAUTION!

Always lift with the throat of the hook. Never lift with the load applied to the tip of the hook. Doing so will bend the hook.

SLINGS If the load does not have a lifting eye, use a nylon, chain, or other type of sling designed for lifting and rated for loads greater than that being lifted.

BALANCE Ensure the load will be secure and balanced when lifted. Ensure that the load cannot shift in the sling and that the sling cannot slide across the hook should the load become unbalanced.

LIFTING THE LOAD

Before lifting, ensure that the load is free from all mountings and is no way attached or stuck to anything.

Ensure that at least five full wraps remain on the winch drum at all times.

Test the winch brake by lifting the load a few inches and ensuring that it does not slip.

HOLDING THE LOAD

The operator must keep the load in sight at all times once it is lifted.



1-6

The operator must never leave the controls once the load is lifted.

The operator must ensure that no one is allowed to pass or stand under a suspended load.

CAUTION!

Never move the vehicle with a suspended load. Doing so will put dynamic loads on the crane for which it was not designed.

MOVING THE LOAD

Before moving the load, make sure the path is free of any obstructions or people.

Avoid sudden accelerations or stops. Speeds must be kept to a minimum, especially rotation, to keep the load from swinging.

Avoid sudden reversing of direction. Do not reverse direction while the load is still moving.

Make sure the that no part of the crane, boom, or load makes contact with any obstruction or comes within a minimum of ten feet from any electrical line.

TRANSIT

While in transit, the crane must be stowed, preferably in a boom rest. The crane must be prevented from rotating and the hook prevented from swinging.



F1449-0
06/07/07

HOUSTON, TEXAS
FAX: (800) 824-5559 (USA & Canada)
FAX: (713) 688-6324
PHONE: (713) 688-5533
www.liftmoore.com

INSPECTION AND MAINTENANCE

OSHA and ANSI require frequent and periodic inspections. Records of these inspections must be kept readily available. Liftmoore requires periodic maintenance to ensure proper operation and prolonged life of the crane.

INSPECTION

DAILY INSPECTION

OSHA 29CFR 1910.180 (d)(2)(i) requires the following be checked daily prior to use:

- All control mechanisms for maladjustment interfering with proper operation as well as for excessive wear of components and contamination by lubricants or other foreign matter.
- All safety devices for malfunction. This should include the anti-two block and pressure switch.
- Deterioration or leakage in air or hydraulic systems.
- Crane hooks with deformations or cracks. For hooks with cracks or having more than 15 percent in excess of normal throat opening or more than 10 deg. twist from the plane of the unbent hook.
- Electrical apparatus for malfunctioning, signs of excessive deterioration, dirt, and moisture accumulation. This should include the battery terminals, master disconnect switch, electrical swivel
- The wire rope shall be replaced if any of the following conditions are noted:

- Kinking, crushing, bird-caging, or other damage
- Reductions from nominal diameter of more than one-sixty-fourth inch for diameters up to and including five-sixteenths inch, one-thirty-second inch for diameters three-eighths inch to and including one-half inch.
- Thimble is not in place or is damaged
- Any evidence of heat damage
- Six or more randomly distributed broken wires in 1 lay
- Three or more broken wires in 1 strand in 1 lay

MONTHLY INSPECTION

A thorough inspection of all ropes in use shall be made at least once a month and a certification record which includes the date of inspection, the signature of the person who performed the inspection and an identifier for the ropes shall be prepared and kept on file where readily available. All inspections shall be performed by an appointed or authorized person. Any deterioration, resulting in appreciable loss of original strength shall be carefully observed and determination made as to whether further use of the rope would constitute a safety hazard. Some of the conditions that could result in an appreciable loss of strength are the following:

- Reduction of rope diameter below nominal diameter due to loss of core support, internal or external corrosion, or wear of outside wires.
- A number of broken outside wires and the degree of distribution of concentration of such broken wires.



- Worn outside wires.
- Corroded or broken wires at end connections.
- Corroded, cracked, bent, worn, or improperly applied end connections.
- Severe kinking, crushing, cutting, or unstranding.

PERIODIC INSPECTION

An Annual Inspection Form is included in this manual. OSHA 29CFR 1910.180 (d)(2)ii) requires periodic inspections of this crane. Liftmoore recommends an annual inspection using the included form.

MAINTENANCE PRECAUTIONS

The crane should be maintained monthly for safety reasons and to reduce stress on the crane.

WARNING!

Never perform any maintenance while the crane has any type of load on it. Use the manual operation procedure to lower the load if necessary.

WARNING!

Hydraulic cylinders may have high pressure stored in them even after hydraulic power is removed.

The counterbalance and pilot operated check valve in the cylinder will always hold some pressure in the cylinder. Slightly extending the cylinder then retracting a small amount will relieve most of the pressure in the cylinder. **DO NOT DEADHEAD THE CYLINDER!** This will store the maximum amount of pressure in the cylinder. Care should be taken when either valve is removed from the cylinder as some pressure will still remain.

After any maintenance has been performed the crane shall not be operated until all guards have been reinstalled, all safety

devices reactivated, and maintenance equipment removed.

LUBRICATION Refer to the crane specification section for the periodic maintenance schedule and type of lubrication required.

BOLTS Bolts may loosen over time due to vibration; therefore they should be checked periodically. If bolts need to be replaced, make sure they are replaced with bolts of equal or greater strength. Check the periodic maintenance schedule (Crane Specification Section) for bolt specification and torque.

NOTE!

Sheave and boom and cylinder pivot bolts are not standard bolts. The shank and thread length of these bolts have been modified so that they do not pivot on the threads. Consult the parts section of this manual for part numbers of these bolts.

OTHER MAINTENANCE

Refer to parts drawings for any specific maintenance or adjustment procedures such as hydraulic winch brake, rotation drive gear set adjustment, Ect.



MONTHLY INSPECTION REPORT

Manual Boom Extension

Crane Model No. _____ Serial Number _____

- Are Boom Hitch Pins and Keepers in place? Yes _____ No _____
- Wire Line Hook with Safety Latch Working? Yes _____ No _____
- Is Hook OK, (Not bent)? Yes _____ No _____
- Is Thimble on Wire Rope OK? Yes _____ No _____
- Does Traveling Block function correctly? Yes _____ No _____
- Is Wire Rope OK, not kinked or frayed? Yes _____ No _____
- Are all Boom Sections straight? Yes _____ No _____
- Are Sheave Bolts in place and tight? Yes _____ No _____
- Do all Sheaves rotate easily? Yes _____ No _____
- Are Mounting Bolts torqued correctly? Yes _____ No _____
- Is Boom Angle Indicator in place and functioning,
and is Chart legible? Yes _____ No _____
- Are Cylinder or Boom Support Mounting Bolts secure? Yes _____ No _____
- Are Winch Mounting Bolts tight? Yes _____ No _____
- When stopped, does winch down drift less than 1.0 Inches? Yes _____ No _____
- Is Load Chart in place and easily read? Yes _____ No _____
- Are functions on Pendant operating correctly? Yes _____ No _____
- Is Hydraulic Reservoir full? Yes _____ No _____
- Is Outrigger or jackstand straight and functioning? Yes _____ No _____
- Any items checked 'No' must be repaired before using this crane.



F1448-0
06/07/07

HOUSTON, TEXAS
FAX: (800) 824-5559 (USA & Canada)
FAX: (713) 688-6324
PHONE: (713) 688-5533
www.liftmoore.com

THIS PAGE INTENTIONALLY LEFT BLANK



HOUSTON, TEXAS
FAX: (800) 824-5559 (USA & Canada)
FAX: (713) 688-6324
PHONE: (713) 688-5533
www.liftmoore.com

206REL PENDANT CONTROL SYSTEM

All user inputs are facilitated by the remote pendant control. The pendant consists of pistol grip housing, function switches, wire, and control plug. The control plug mates with the crane control socket.

Elevation and Rotation function switches activate the hydraulic pump along with the applicable function valve.

Hoist Up and Elevation Down output signals are dependant on an input signal from the load sensor. If the load sensor is activated then these functions will not work until the overload condition is corrected.

OPERATION

Plug the pendant into the crane control socket. Ensure all pins are straight and free of dirt, moisture, and corrosion. Turn the locking ring approximately 1/3 turn until it clicks into the locked position.

Select the function switch and direction as indicated on the label for the desired operation.

CARE AND MAINTENANCE

The pendant control is designed to be as rugged and maintenance free as possible; however, care should be used in handling and storage as it is expensive to replace.

Follow these simple practices:

- Keep the pendant out of the weather
- When not in use, store the pendant inside the vehicle
- Do not wrap the wire too tightly as internal damage to the wires may result
- Do not place sharp or heavy objects on the cord

NOTE!

The pendant is designed to be weatherproof not waterproof. It may be used in inclement weather, but if left outside or where water can puddle, water can seep inside.

Maintenance should be limited to routine inspection of the plug, wire, and fasteners.

SAFETY SYSTEM

The safety system is designed to help prevent damage to the crane that would be caused by overload. When the pressure switch detects an overload, winch up and boom down are deactivated since these directions would cause damage. Winch down, boom up, and power rotation will still function so that the crane can be moved to a safe configuration.

CAUTION!

Never de-activate or override safety functions. Doing so can result in serious damage to the crane and possibly injury or death.

LOAD SENSOR

A pressure activated switch in the elevation cylinder acts as a load sensor. This switch is normally closed and opens at the preset pressure corresponding to the rating of the crane.

CAUTION!

The load sensor will not function when the elevation cylinder is fully retracted and is inaccurate when the boom is below horizontal.

CAUTION!

The operator must never rely strictly on the load sensor to determine overload conditions. The load and load limits must always be known and adhered to.



MISCELLANEOUS

UP LIMIT SWITCH

The up limit switch prevents the elevation cylinder from reaching full extension. If the elevation cylinder were to "dead-head", the resulting pressure would activate the load sensor, preventing boom down. The boom would then have to be lowered using the manual operation buttons on the solenoid valves.

FUSE

A fuse is supplied with the crane and should be installed as close to the battery as possible.

DISCONNECT SWITCH

A power disconnect switch is supplied with the crane. Power to the crane should be turned off whenever not in use. This is to prevent inadvertent or unauthorized use and will help prevent corrosion at electrical connections.



HYDRAULIC SYSTEM FOR ELECTRIC CRANES

The hydraulic system consists of the hydraulic pump, manifold, solenoid valves, cylinders, motors, and tubing and hoses. Hydraulic power is generated by the electrically driven hydraulic pump on the outside of the housing. The hydraulic system is plumbed in series so that more than one function can be operated simultaneously.

PUMP

The hydraulic pump assembly consists of a DC permanent magnet electric motor, pump, and reservoir.

The motor is activated by the pump solenoid. The solenoid is energized by the pendant control whenever a hydraulic function is activated.

The pump provides fluid pressure to power hydraulic functions. The system incorporates an adjustable relief valve to prevent damage that can be caused by over pressurizing the system.

Fluid is drawn from and returned to the reservoir. Servicing the hydraulic pump consist of maintaining the oil level. The reservoir should be kept as full as possible to prevent condensation from forming inside the tank. Also ensure the oil is not contaminated by water, dirt, rust, etc. See crane specification sheet for hydraulic oil type.

SOLENOID VALVES

Each hydraulically operated function is controlled by a 4-way, 3-position open center solenoid valve. It is electrically operated and spring biased to center. A manual operation button is incorporated in the coil-retaining nut. Valves are mounted to the series manifold.

CYLINDERS

Most hydraulic cylinders are double acting cylinders with integrally mounted counterbalance valve and pilot operated check valves. Refer to the cylinder drawings for specific information.

All cylinders use a counter-balance load holding cartridge valve on the extend port.

This valve performs 3 functions:

- Controls the rate of decent when lowering the load
- Keeps load from falling in the event of sudden loss of system pressure, such as when a hose bursts.
- Acts as a relief valve to prevent damage from induced load or thermal expansion.

It allows free flow to extend then blocks flow until opened by pilot pressure to the retract port or when the relief pressure is reached.

Some cylinders utilize a pilot operated check valve on the retract port to prevent the cylinder from creeping out under no load conditions. This valve allows flow into, but prevents flow from the retract port, thus hydraulically locking the cylinder until opened by pilot pressure to the extend port.

MOTORS

The hydraulic motor used by the rotation drive is a high-torque, low-speed constant displacement motor.



MANUAL OPERATION

If electrical problems occur the solenoid valves may be operated manually by depressing the manual operation button incorporated in the coil-retaining nut. Using a blunt object such as a bolt or screwdriver handle may be required to assist operation if high pressures are needed. Refer to the manifold drawing for function valves and directions.

If possible, activate the pump by activating a hydraulic function on the pendant. If this does not work, then energize the pump solenoid using a jumper from the hot side of the solenoid to the coil post where the WHT/BLK wire is connected. If this fails also then battery voltage can be applied directly to the pump motor.

If hydraulic power is lost while a load is suspended, the load can be lowered by decreasing the setting on the counter-balance valve. This should only be done in extreme cases. The valve must be reset before the crane is returned to use.

WARNING!

The boom may fall if the adjustment is made too fast. Do not stand where the boom may hit you if it falls. Serious injury or death may result

WARNING!

The area between the boom and the cylinder, the boom and the housing, and the cylinder and the housing will change as the boom position changes and could form pinch points. Do not position any part of your body in these areas as it may be pinched or crushed as the boom lowers.

To decrease the setting, loosen the locknut on the valve, then slowly turn the adjustment stem **CLOCKWISE** until the load begins to lower. Count the number of turns so that the valve can be returned to its original setting.

Alternately, a pressure gage must be put on the retract port to adjust the setting so that approx. 1800 PSI is required to lower the boom with no load.

Test the setting by lifting a known load near the moment rating

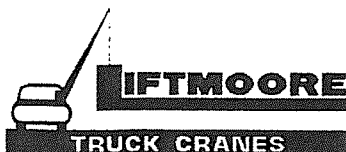

F1145-C
10/22/04

HOUSTON, TEXAS
FAX: (800) 824-5559 (USA & Canada)
FAX: (713) 688-6324
PHONE: (713) 688-5533
www.liftmoore.com

TROUBLESHOOTING ELECTRIC CRANES

LOAD SENSOR LIMITING IN PENDANT

GENERAL

If a problem exists, always start with the basics and work towards the more complicated.

On electric cranes, power enters the crane through an electric swivel, runs to the solenoid and is jumpered to the winch contactor on the outside of the housing. The contactor sends electrical power to the winch when it receives a 12V input signal. Similarly, the hydraulic pump is switch through the solenoid when a hydraulic function (rotation, elevation, or extension) is activated.

When diagnosing an electrical problem, it is important to start by ensuring that the crane is receiving full electrical power from the battery and that the crane is properly grounded. Running the truck is a good way to ensure proper battery power, but caution must be used to avoid carbon monoxide poisoning in closed areas. The diagnosis begins by verifying that power is getting through the swivel.

POWER IN AND SWIVEL

If a problem exist, first ensure that the crane is receiving full voltage of at least 12VDC.

Start by checking for power out of the truck at the Mecon connector on the bottom of the crane. Next, check for power on the top post of the solenoid mounted inside the crane housing. If this post does not have power, but the Mecon connector does, the problem is in the electric swivel. See the Electric Swivel Assembly drawing for a full breakdown of the electric swivel and to order parts.

HYDRAULIC PUMP POWER

If power is being transmitted through the swivel, but the hydraulic pump will not run there may be a problem in the pump solenoid. First, ensure that the solenoid is grounded properly by checking continuity between the truck frame and the grounding post on the solenoid.

Next, inspect the incoming power wire from the swivel, the outgoing jumper to the pump, and the pump ground wire for corrosion or breaks.

Finally, check for 12V at the White/Black control wire when a hydraulic function switch is activated. If this has power but the motor wire does not, the solenoid may be bad or poorly grounded.

ELECTRIC WINCH

Because the winch is reversible and electrically operated, a contactor is used to supply the electrical power to the unit. The contactor is under the crane cover on the outside of the crane housing.

If the winch is not functioning properly, first verify that the contactor is receiving full power from the positive jumper on the solenoid and that the contactor is properly grounded.

Next, check that the control wires from the receiver are supplying 12V of signal when a winch function is activated.

If all these check out but the positive motor wire at the winch is dead, the contactor may need replacement.



HOIST UP / BOOM DOWN

If Hoist Up and Boom Down out do not work, the problem is likely in the crane safety system. The problem may be the load sensor, the associated wiring, or the pendant.

CHECK LOAD SENSOR

Check Pin M on the crane control socket. If this pin has voltage, then the load sensor is good. Check the pendant.

If Pin M is not receiving voltage, locate the load sensor wire inside the crane housing. It is a two-conductor wire: red and white. The red wire is connected to the GRN/BLK wire from the control socket and the white wire is connected to a white power wire in the crane.

Disconnect and check for continuity between the two load sensor wires. If there is no continuity, the load sensor is bad and needs to be replaced.

Check the white wire on the crane to ensure that it is receiving voltage, if not, check the fuse and follow the wiring back to the power input (see the Power In and Swivel section above if necessary) checking for loose connections or broken wires.

SOLENOID VALVES

If one function does not work, try to operate it manually. If it does not work, either the solenoid or the applicable actuator is malfunctioning. Contact Liftmoore for more information.

If it works manually, then the problem is electrical. Disconnect the electrical connector going to the applicable solenoid valve. Check for voltage when the switch is activated, the voltage should be at least 12V (battery voltage).

If no voltage is received, check the continuity between the connector and the applicable pin on the crane control socket for non-safety function or the relay card for

safety functions. If there is no continuity, then a check for broken wires or bad connections. If the wiring is good, then check the control pendant or relay card.

If the voltage checks good, check the resistance on the coil. Connect an ohmmeter to the applicable pin on the receptacle and ground. The resistance should be between 5 and 6 ohms. If the resistance is near zero then the coil is shorted and needs to be replaced.

If the circuit is open, then check ground on the valve coil. Also check for continuity between the manifold and the crane. If there is no continuity, remove one of the manifold's mounting bolts, clean under the head and reinstall.

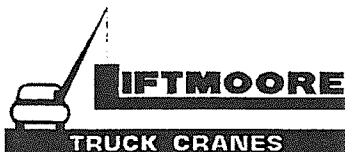

PENDANT (NON-FM)

If no functions work, check that Pin E on the crane control socket has power.

If the crane control socket is getting power, then check that the power wire is not broken. Select a function and direction then check continuity between Pin E and the activated function/direction on the pendant control plug. If there is no continuity then the pendant needs to be repaired or replaced.

FOR HOIST UP AND BOOM DOWN

With the pendant disconnected, activate the function and check for continuity between the function's pin (see table) and Pin M.

FOR ANY OTHER FUNCTION

Check continuity between that function pin (see table) and Pin E on the pendant control plug. There should be continuity once the switch is activated in selected direction.

For hydraulic functions, there should also be continuity between Pin E and Pin K. The continuity should break when the switch is released.

If these conditions are not met then the pendant needs to be repaired.

FUNCTION PINS:

Pin	Function	Color
E	POWER	WHT
F	ROTATE CW	RED
G	ELEV UP	GRN
H	ELEV DWN	ORN
J	HOIST UP	BLU
K	PUMP	WHT/BLK
L	ROTATE CCW	RED/BLK
M	LOAD SENSOR	GRN/BLK
P	HOIST DWN	BLK



F1173-0
4/30/03

HOUSTON, TEXAS
FAX: (800) 824-5559 (USA & Canada)
FAX: (713) 688-6324
PHONE: (713) 688-5533
www.iftmoore.com

THIS PAGE INTENTIONALLY LEFT BLANK



HOUSTON, TEXAS
FAX: (800) 824-5559 (USA & Canada)
FAX: (713) 688-6324
PHONE: (713) 688-5533
www.liftmoore.com

SECTION 3 CRANE SPECIFICATIONS

MODEL 206REL CRANES

MOMENT RATING 6500 FT-LBS

MAX SINGLE LINE LOAD 1000 LBS

MAX DOUBLE LINE LOAD 2000 LBS

LIFTING CAPACITIES AT VARIOUS LOAD RADII

LOAD RADIUS (FT)	CAPACITY (LBS)
3	2167
5	1300
6	1083
7	929
9	722

HOIST FOR THE M (P/N 22289)

LOAD (LBS)	LINE SPEED (FT/MIN)	AMP DRAW
0	26	25
500	22	70
1000	18	115

ELECTRICAL REQUIREMENTS

VOLTAGE	12 VDC	
CIRCUIT BREAKER	150 AMP	
FUSE	15 AMP	(CONTROL WIRING)

NOTE: FUNCTION TIMES ARE BASED ON THESE INPUT VALUES



F1450-D
12/16/09

HOUSTON, TEXAS
FAX: (800) 824-5559 (USA & Canada)
FAX: (713) 688-6324
PHONE: (713) 688-5533
www.liftmoore.com

CRANE SPECIFICATIONS

(Continued)

MODEL 206WREL CRANES

MOMENT RATING 6500 FT-LBS

MAX SINGLE LINE LOAD 2000 LBS

LIFTING CAPACITIES AT VARIOUS LOAD RADII

LOAD RADIUS (FT)	CAPACITY (LBS)
<3	2000
4	1625
6	1083
8	813
10	650
12	542

HOIST FOR THE WM (P/N 22803)

LOAD (LBS)	LINE SPEED (FT/MIN)	AMP DRAW
0	17	25
400	16	45
1200	14	85

ELECTRICAL REQUIREMENTS

VOLTAGE	12 VDC	
CIRCUIT BREAKER	150 AMP	
FUSE	15 AMP	(CONTROL WIRING)

NOTE: FUNCTION TIMES ARE BASED ON THESE INPUT VALUES

F1450-D
12/16/09HOUSTON, TEXAS
FAX: (800) 824-5559 (USA & Canada)
FAX: (713) 688-6324
PHONE: (713) 688-5533
www.liftmoore.com

PERIODIC MAINTENANCE SCHEDULE MODEL 206 CRANES		
BOLTS		
MOUNTING BOLTS	1/2-13 GRADE 8 TORQUE 110FT-LBS DRY	EVERY 4 MONTHS
LUBRICATION		
GREASE FITTINGS	SEE DRAWING 50470	EVERY OTHER WEEK
HYDRAULIC FLUID	STANDARD Chevron AW Hydraulic Oil 46 or equivalent SAE 15 weight oil COLD WEATHER AW 32 or equivalent SAE 10 weight oil	CHECK DAILY, FILL AS NEEDED
BEARING (ZERK AND TEETH)	Oil Center Research PM 600 Military grease or equivalent Benton Based Grease NLGI Grade 2	EVERY 6 HOURS OF OPERATION

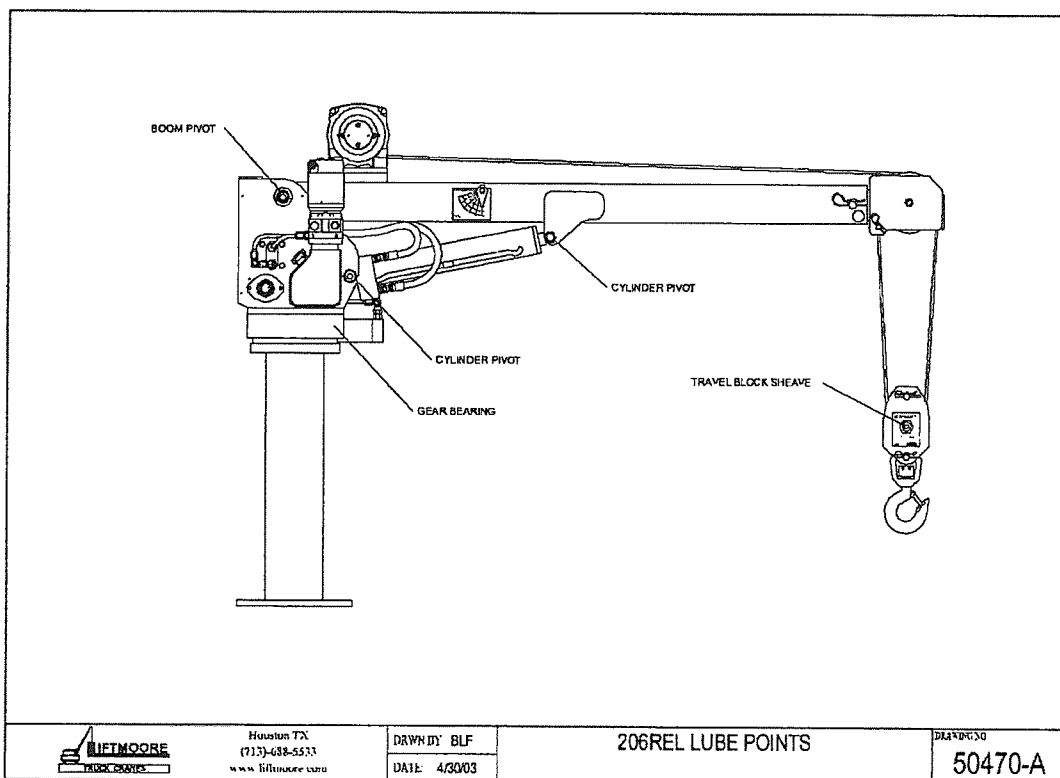

F1450-D
12/16/09

HOUSTON, TEXAS
FAX: (800) 824-5559 (USA & Canada)
FAX: (713) 688-6324
PHONE: (713) 688-5533
www.liftmoore.com

THIS PAGE INTENTIONALLY LEFT BLANK



HOUSTON, TEXAS
FAX: (800) 824-5559 (USA & Canada)
FAX: (713) 688-6324
PHONE: (713) 688-5533
www.liftmoore.com

LIST FOR BOX, CRANE PARTS 206
REL/WREL/RELS/WRELS W / ATB
Items with * have detailed DWG's.

4-1

P/N 26971 - BOX, CRANE PARTS 206REL

- 1) P/N 26970 - MANUAL, CRANE 206REL/RELS 1pc
- 2) P/N 33021 - WIRE, BATTERY #1 X 25' WMECON..... 1pc
- 3) P/N 26084 - WIRE, GROUND 1/0 X 3' LONG..... 1pc
- 4) P/N 30760 - PIN, HITCH 0.75 X 4.50 W/H-PIN..... 1pc
- 5) P/N 30815 - SCREW, HHC 0.50-13 X 2.50 GR8..... 4pcs
- 6) P/N 30474 - WASHER, LOCK 0.50 GR5 PLATED..... 4pcs
- 7) P/N 31957 - NUT, HEX 0.50-13 GR8 PLATED..... 4pcs
- 8) *P/N 22599 - BLOCK, TRAV ASSY 2.0K LBS/4.0D 1pc
- 9) P/N 16878 - BREAKER, CIRCUIT 150 AMP..... 1pc
- 10) P/N 16915 - TERMINAL, LUG #1 GA 0.25 DIA..... 2pcs
- 11) P/N 30766 - SWITCH, DISCONNECT..... 1pc
- 12) P/N 17010 - BRACKET, SWITCH MNT. ELE. CRN..... 1pc
- 13) P/N 17063 - TERMINAL, LUG #1 GA 0.37 DIA..... 2pcs
- 14) P/N MH*03171 - CAP, BREATHER 3/8 NPT-MONARCH..... 1pc
- 15) P/N 17181 - SCREW, HHC 0.62-11 X 2.75 GR8..... 4pcs
- 16) P/N 34038 - NUT, HEX 0.62-11 GR8 PLATED 4pcs
- 17) P/N 31461 - WASHER, LOCK 0.62 GR5 PLATED..... 4pcs
- 18) P/N 31054 - WASHER, FLAT 0.62 SAE GR8..... 4pcs
- 19) P/N 22571 - INSTALLATION INTS. 206 & LA6K..... 1pc
- 20) P/N 25975 - DECAL, LOAD CAPACITY 6,500..... 1pc



F2228-0
12/22/14

HOUSTON, TEXAS
FAX: (800) 824-5559 (USA & Canada)
FAX: (713) 688-6324
PHONE: (713) 688-5533
www.liftmoore.com

NOTE:
 REFERENCE DWG # 58416
 BAIL ATB ASSEMBLY
 FOR INSTALLATION & PARTS

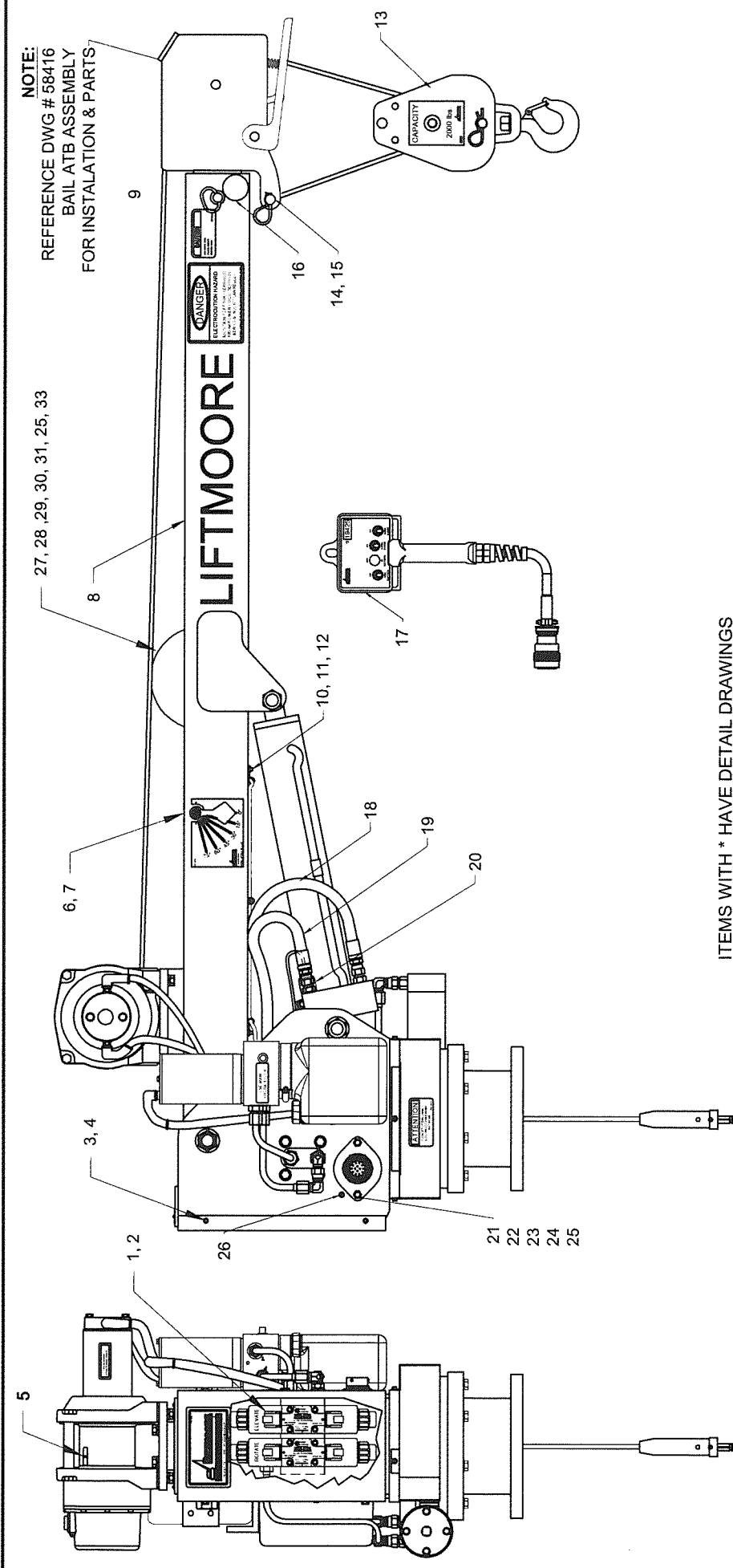

ITEMS WITH * HAVE DETAIL DRAWINGS

#	PN	DESCRIPTION	QTY	#	PN	DESCRIPTION	QTY	#	PN	DESCRIPTION	QTY
1	24816	VALVE ASSY 4W/3P/12V/TC DTCH	2	14	31603	CLIP, HAIRPIN 0.50 - 0.62	1	27	20407	REEL, CORD 20 FT ASSY DTCH	1
2	30956	SCREW, SOC HD 10-24 X 2.00	8	15	32657	PIN, CLEVIS 0.56 X 2.00 PLATED	1	28	70012	BRACKET, CORD REEL.	1
3	19405	COVER, BACK 206	1	16	31036	STOP, BOOM INNER ASSY STD.	1	29	33410	SCREW, MH RD 10-24 X 3.00	1
4	32589	SCREW, HWHSMS 0.25-20 X 0.75	4	17	19425	CONTROL, PENDANT 206REL LS	1	30	33409	NUT, HEX NYLOC 10-24 GR2	2
5	70022	WEDGE, WIRE ROPE ANCHOR	1	18	19503	HOSE, HYD #4 24.50"	1	31	30457	SCREW, HHC 0.25-20 X 0.75 GR5	2
6	22394	PENDULUM, LOAD RADIUS DIA. HD	2	19	19502	HOSE, HYD #4 26.50" 45"-ST	1	32	31110	WASHER, FLAT 0.25 GR5 PLATED	2
7	31017	SCREW, SHOULDER 0.31-18 X 0.75	2	20	25887	SWITCH, PRES ASSY SET@ 2050PSI	1				
8	19582	ROPE, WIRE 0.18 X 35' WTHB&LP	1	21	25573	SOCKET ASSY 14PIN/10WIRE 30"	1				
9	19847	CONNECTOR, DTCH 2P PLUG	1	22	30810	SCREW, HHC 0.25-20 X 1.00 GR5	1				
10	24960	CLAMP, HOSE SUPPORT 0.25 ID	3	23	30809	SCREW, HHC 0.25-20 X 0.50 GR5	1				
11	30889	WASHER, LOCK 0.25 GR5 PLATED	3	24	30889	WASHER, LOCK 0.25 PLATED	2				
12	26582	SCREW, SOC HD 0.25-20 X 0.37SS	3	25	30833	NUT, HEX NYLOC 0.25-20	3				
13	22599	BLOCK, TRAV ASSY 2.0K LBS/4.0D	1	26	33144	SCREW, MH HX 10-24 X 0.50	1				

NOT SHOWN:
 19462 PLATE, SERIAL 206
 19449 DECAL KIT 206

Houston TX
 (713)-688-5533
 www.liftmoore.com

DRWN BY: AT
 DATE: 12/19/14

CRANE ASSY 206REL / ATB
 DTCH VALVE WWINCH 22289 W/ATB

DRAWING NO. **26969-0**

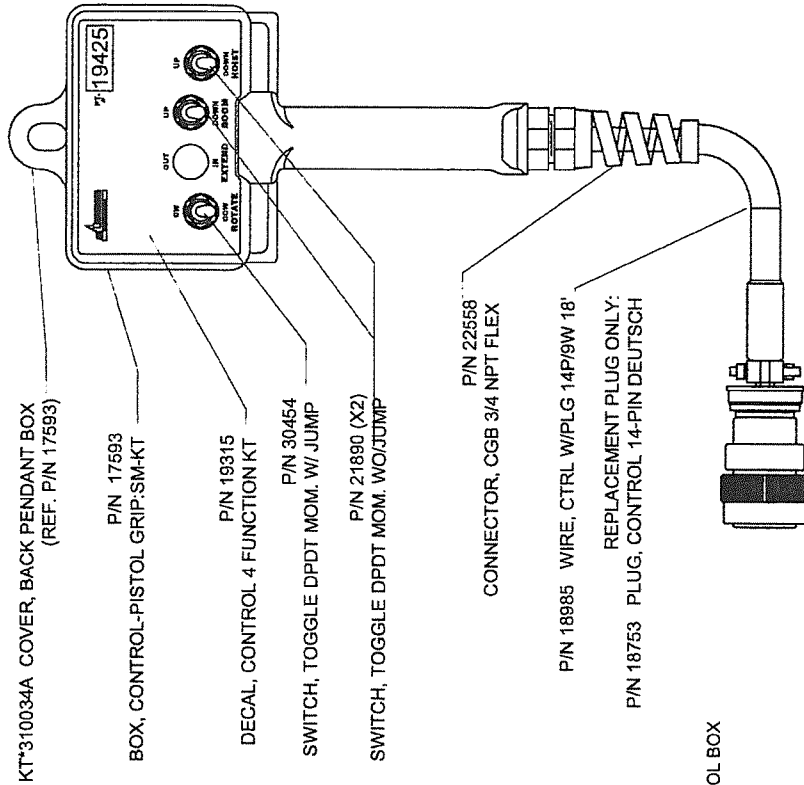
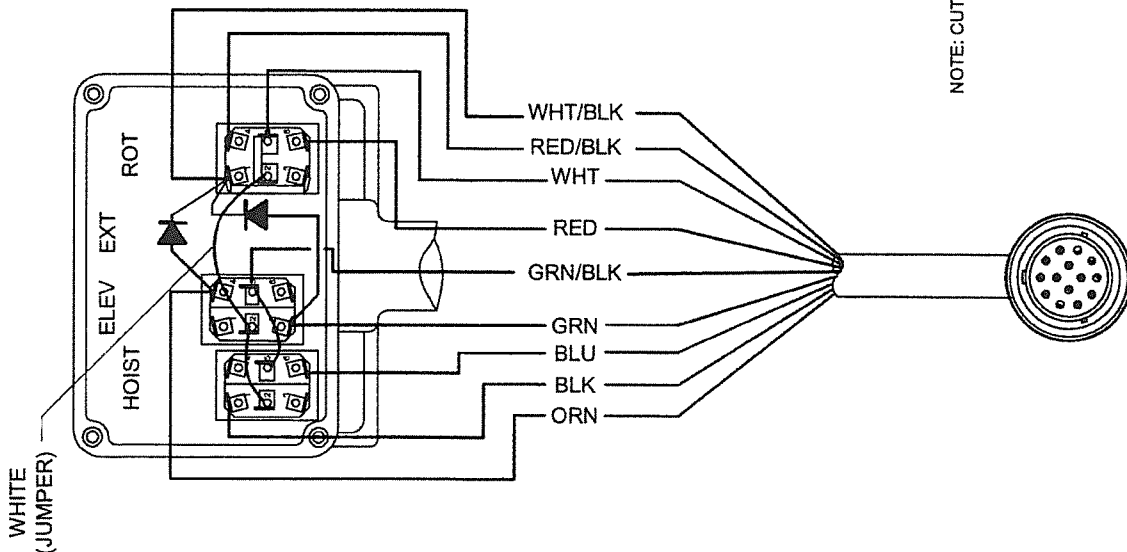
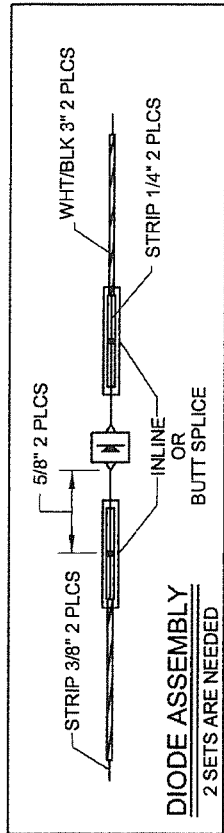

PIN LOCATION	WIRE FUNCTION	WIRE COLOR
E	POWER	WHT
F	ROATION CW	RED
G	ELEV UP	GRN
H	ELEV DWN	ORN
I	HOIST UP	BLU
J	PUMP SOLN.	WHT/BLK
K	ROTATION CCW	RED/BLK
L	PRESS SWITCH	GRN/BLK
M	HOIST DOWN	BLK
P		

NOTE: CUT OFF ORN/BLK @ END OF CABLE INSIDE CONTROL BOX

DRAWING NO.
19425-E

CONTROL, PENDANT 206REL LS

DRWN BY: JC
DATE: 01/29/09

Houston TX
(713)-688-5533
www.liftmoore.com



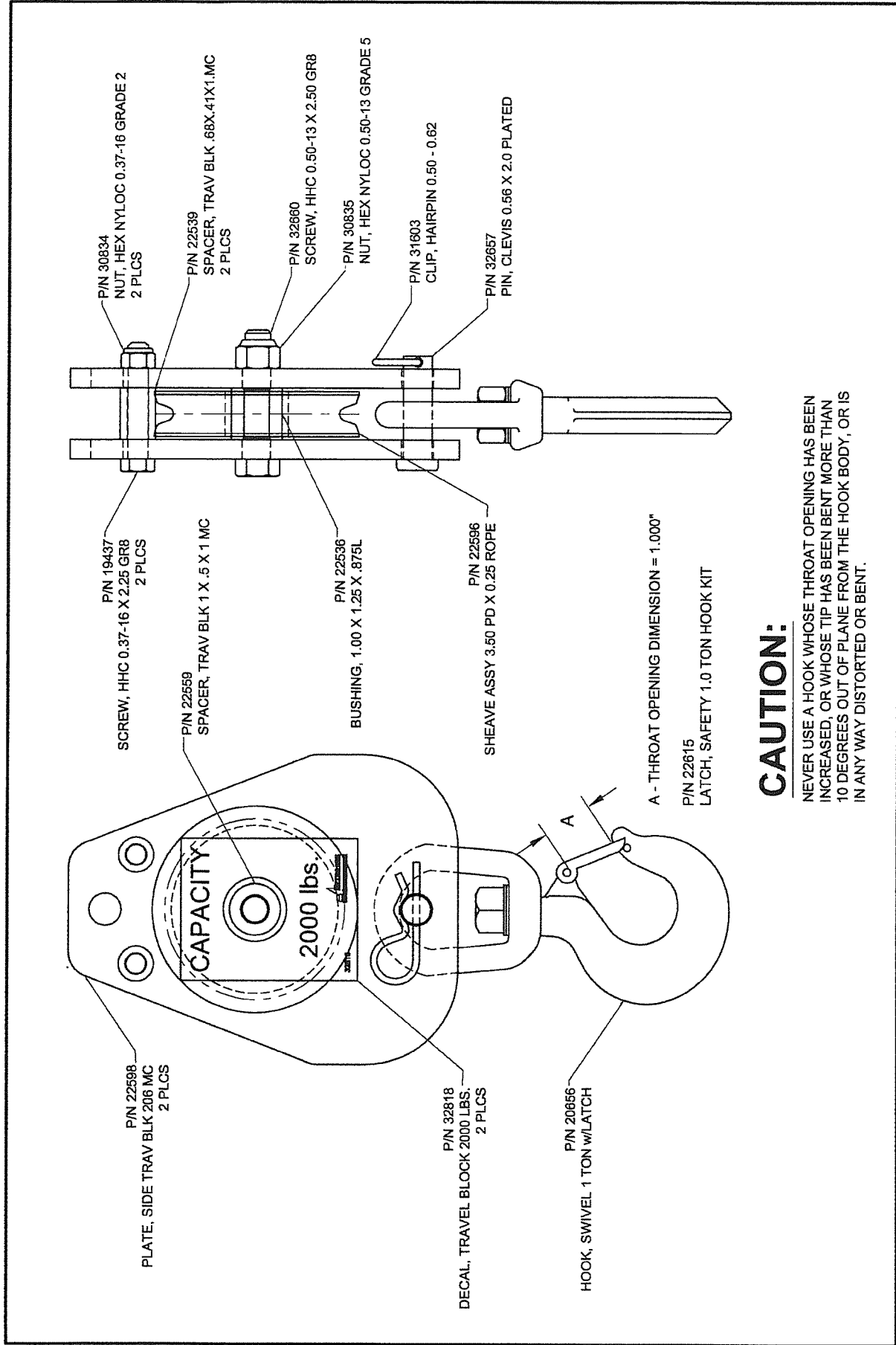

CAUTION:

NEVER USE A HOOK WHOSE THROAT OPENING HAS BEEN INCREASED, OR WHOSE TIP HAS BEEN BENT MORE THAN 10 DEGREES OUT OF PLANE FROM THE HOOK BODY, OR IS IN ANY WAY DISTORTED OR BENT.

<p>DRAWING NO. 22599-A</p>	<p>BLOCK, TRAV ASSY 2.0K LBS/4.0D 3.50 PD, .25" & .18" ROPE 2000K</p>	<p>HOUSTON TX DRAWN BY: JC DATE: 8/23/07</p>	<p>HOUSTON TX (713)-688-5533 www.liftmoore.com</p> 
---------------------------------------	--	--	--

P/N 17424
SCREW, HHC 0.75-10 X 7.75 GR8
2 PLCS

P/N 30836
NUT, HEX NYLOC 0.75-10 GRADE 5
2 PLCS

P/N 70009
BOOT, RUBBER 1 & 1/0
2 PLCS

*P/N 26967
BOOM ASSEMBLY 206

P/N 19018
SCREW, HHC 0.75-10 X 6.00 GR8
P/N 30836
NUT, HEX NYLOC 0.75-10 GRADE 5

*P/N 19448
CYLINDER ASSY 206 ELEV. L.S.

*P/N 25575
BODY ASSEMBLY 206REL/WREL / DTCH VALVE

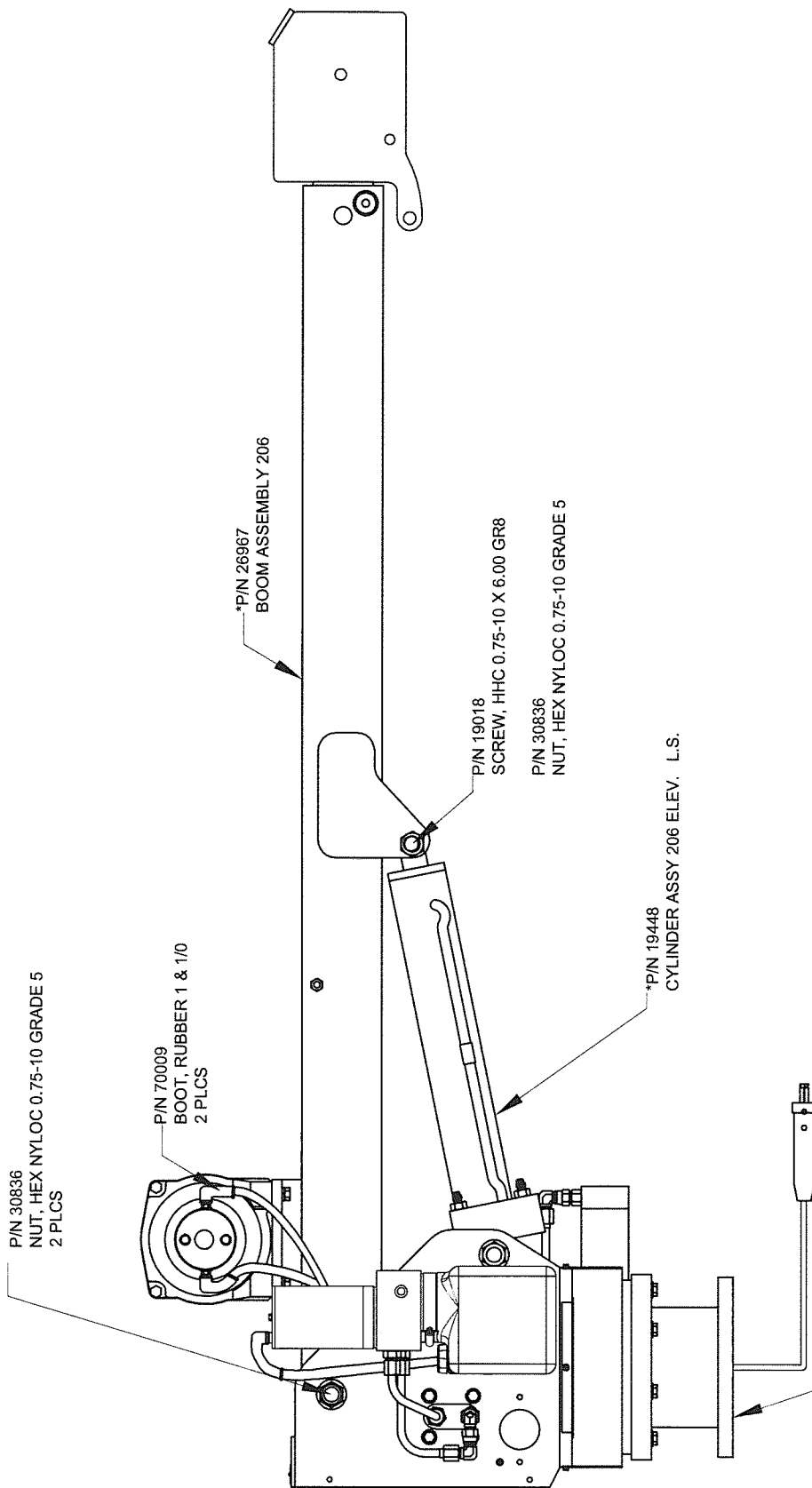

DRAWING NO.

26968-0

BOOM-BODY ASSY 206REL ATB

DTCH VALVE W/ WINCH P/N 22289 W/ATB

DRWN BY: AT

DATE: 12/18/14

Houston TX
(713)-688-5533
www.lifmoore.com



SWITCH, PRES ASSY 2050PSI DTCH
SEE CRANE ASSEMBLY DRAWING
FOR PART NUMBER
(NOT PART OF ASSEMBLY)

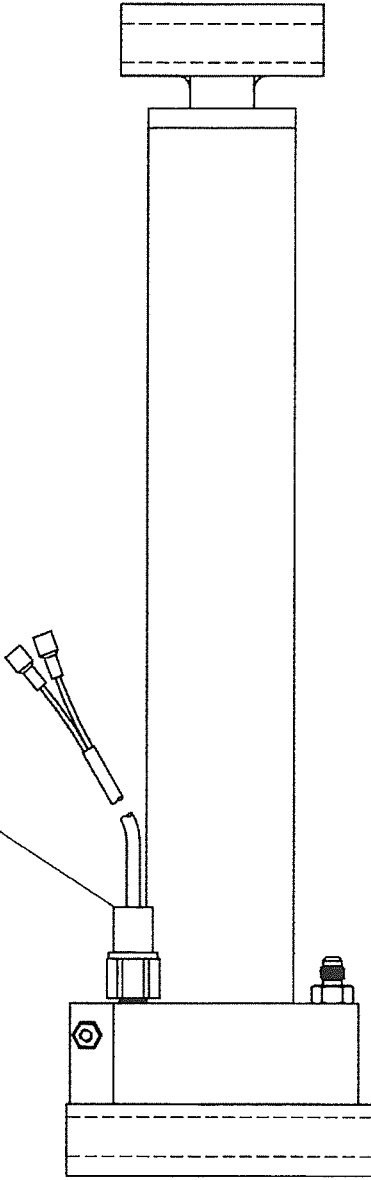

P/N 32400
ADAPTER, 4MJ-6MO
2 PLCS

P/N 19399
CYLINDER, 2.5 X 13.0 X 1.25 PE

P/N 30457
SCREW, HHC 0.25-20 X 0.75 GR5
P/N 30830
NUT, HEX 0.25-20 GR2 PLATED
FOR UPLIMIT SWITCH

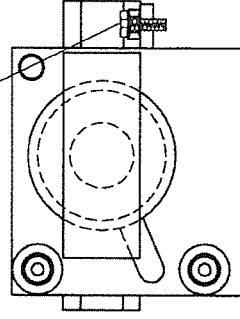

REPLACEMENT PARTS FOR CYLINDER	
DESCRIPTION	PART NUMBER
SEAL KIT	TM*SK-00870
COUNTERBALANCE VALVE	TM*PP-00259

Lifmoore TX
(713)-688-5533
www.lifmoore.com



CYLINDER ASSY 206 ELEV. L.S.

DRAWING NO.

19448-D

DRWN BY: JC

DATE: 10/02/09

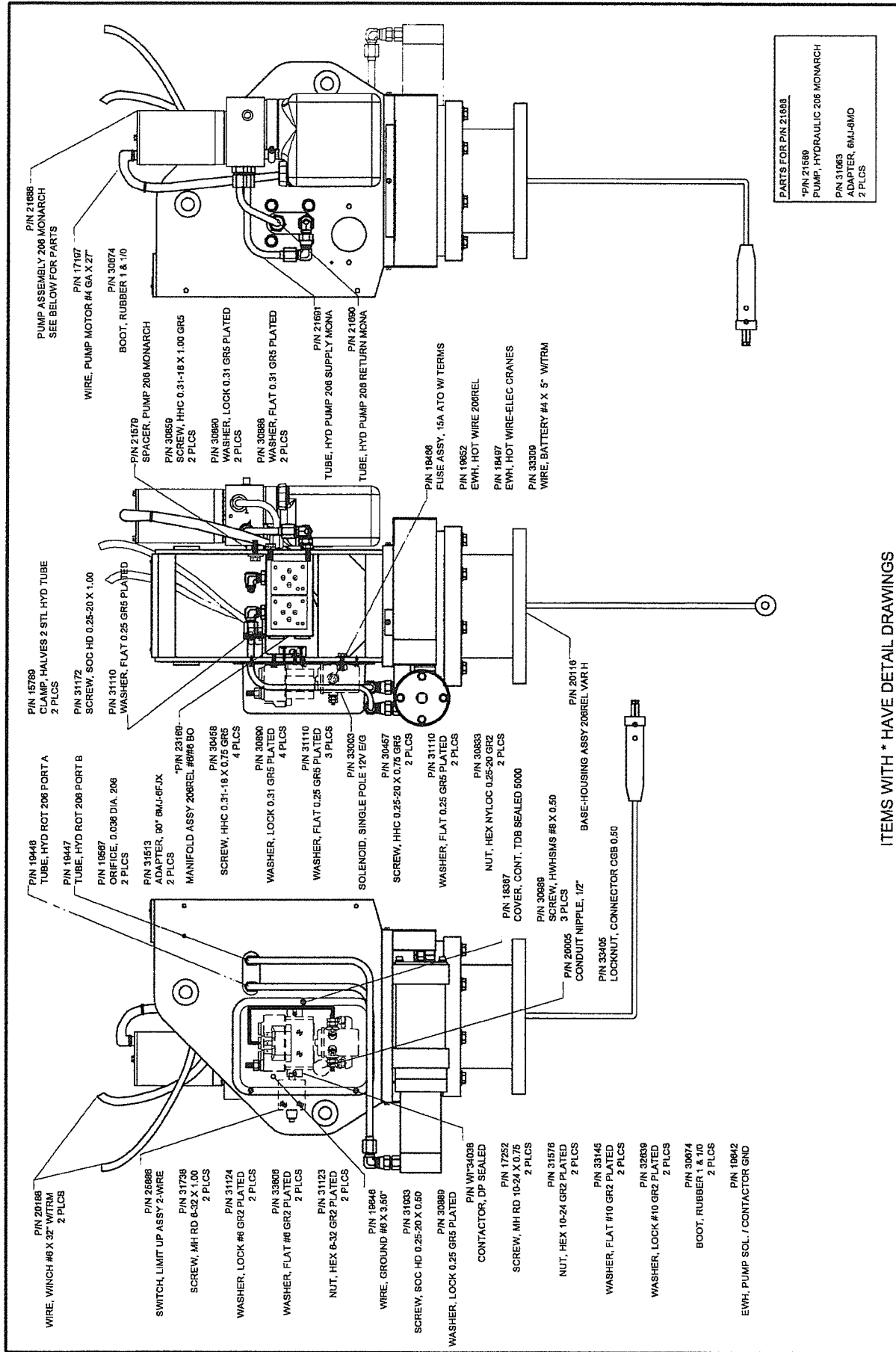

PARTS FOR PIN 21088
 *PIN 21690
 PUMP, HYDRAULIC 206 MONARCH
 PIN 31063
 ADAPTER, 6MJ-6MO
 2 PLCS

ITEMS WITH * HAVE DETAIL DRAWINGS

DRAWING NO.
25575-A

BODY ASSEMBLY 206REL/WREL
 SHORTY & VARIABLE HEIGHT

DRWN BY: JE
 DATE: 2/25/13

Houston TX
 (713)-688-5533
 www.liftmoore.com



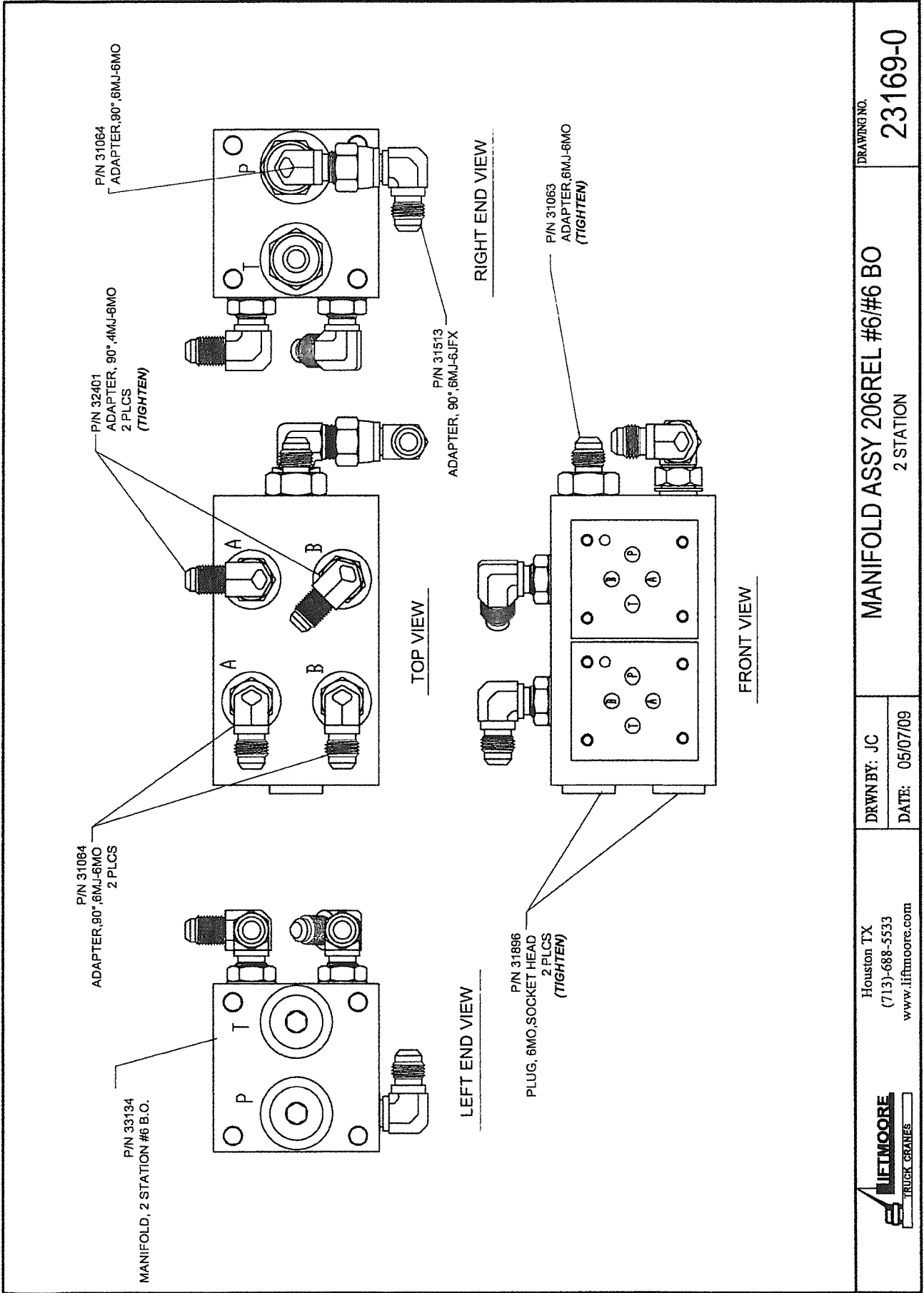

	Houston TX (713)-688-5533 www.liftmoore.com	DRAWN BY: JC DATE: 05/07/09	DRAWING NO. 23169-0
	MANIFOLD ASSY 206REL #6/#6 BO 2 STATION		

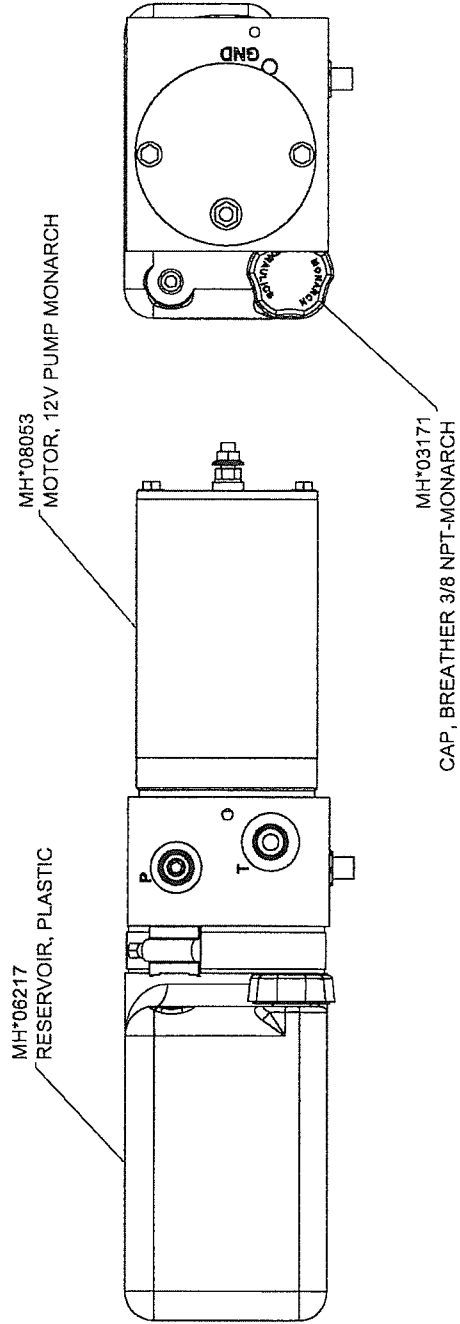
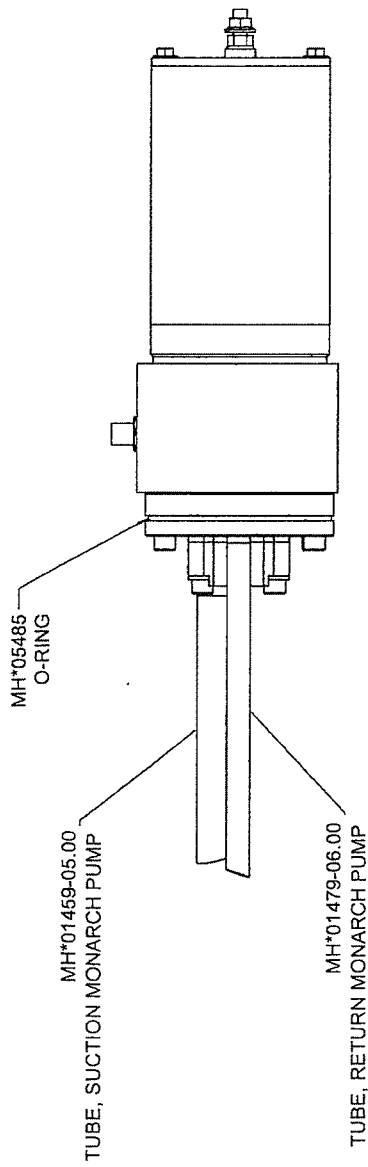

Houston TX
(713)-688-5533
www.liftmoore.com

DRWN BY: TV
DATE: 04/01/05

PUMP, HYDRAULIC 206 MONARCH

DRAWING NO.

21589-A



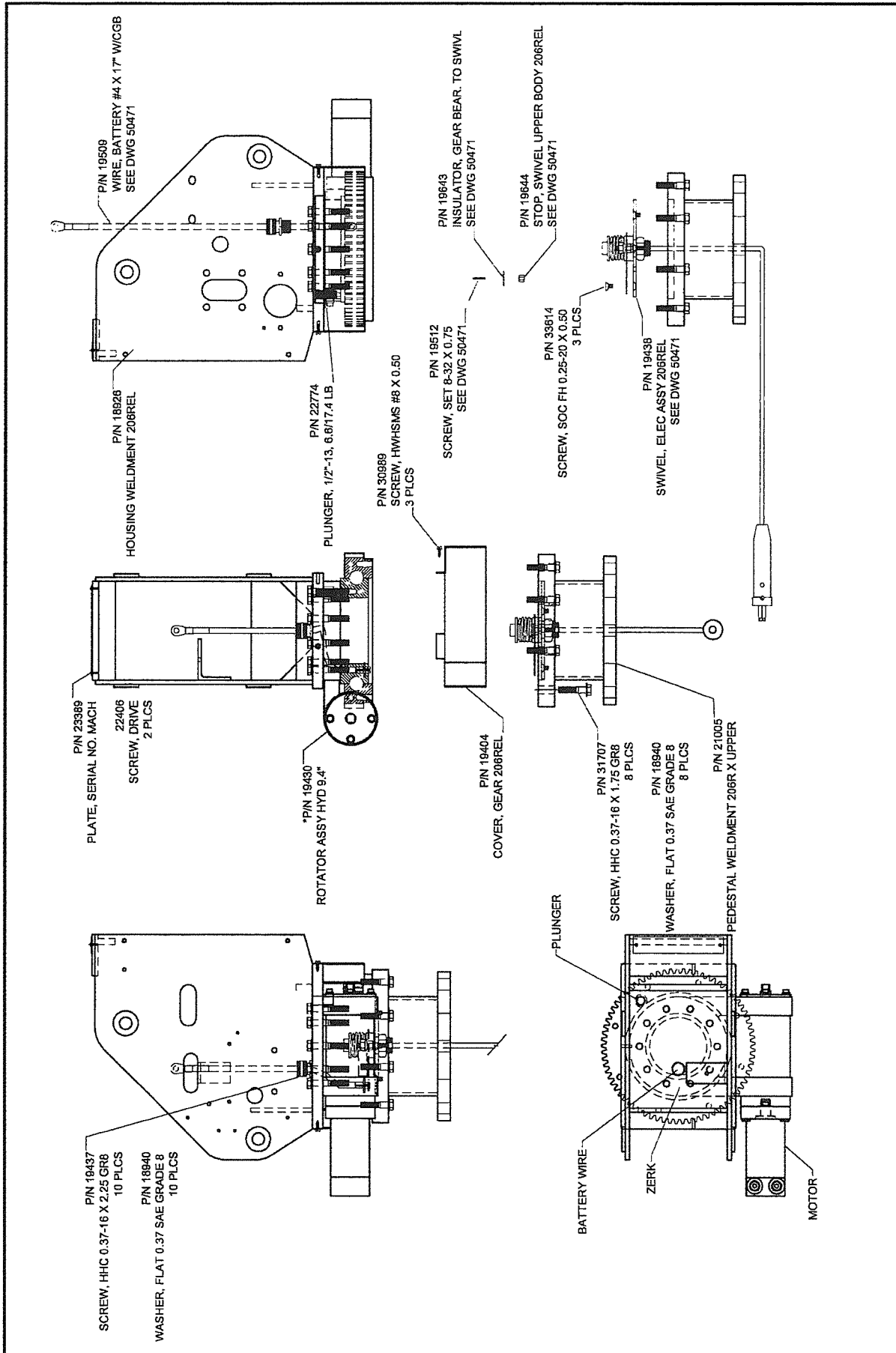

 <p>Houston TX (713)-688-5533 www.liftmoore.com</p>	DRWN BY: JC	BASE-HOUSING ASSY 206REL/WREL SHORTY & VARIABLE HEIGHT	DRAWING NO. 20116-F
	DATE: 12/14/09		

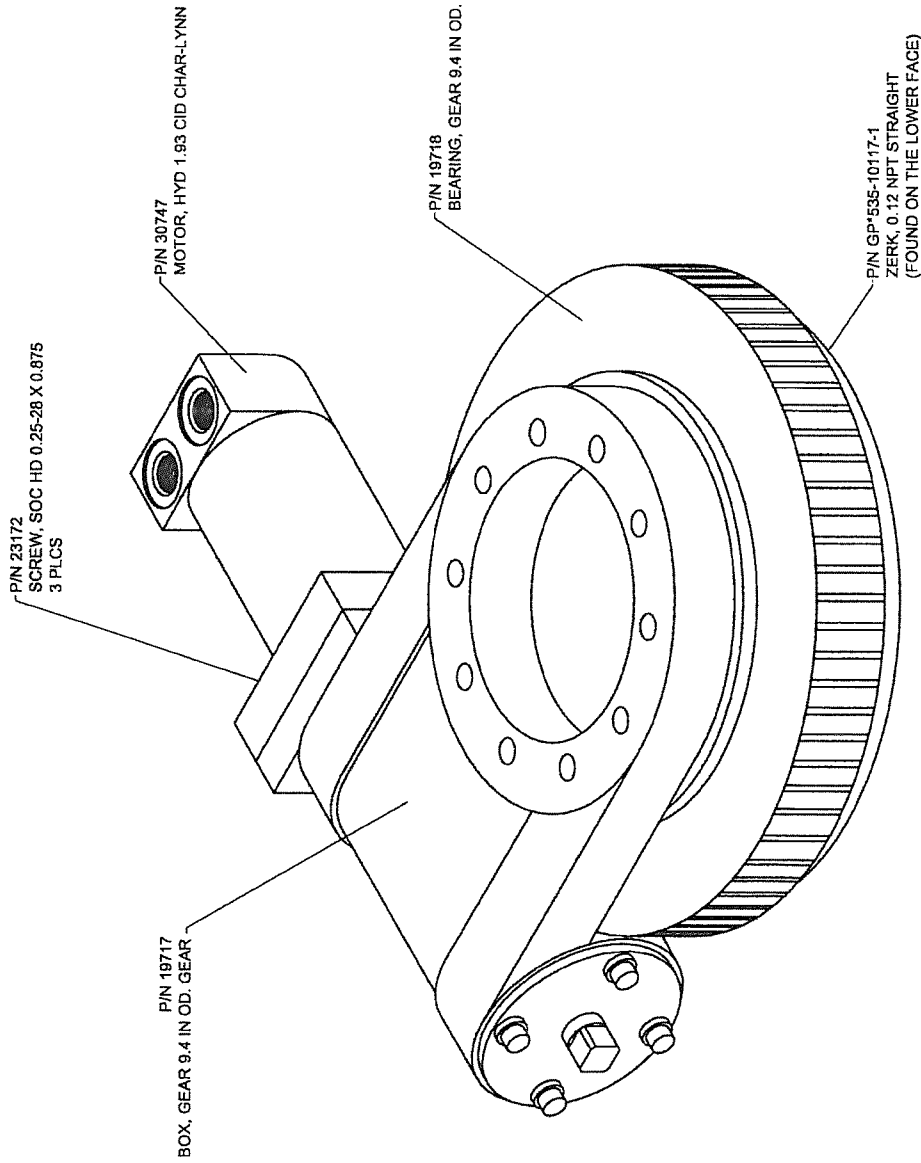

Houston TX
(713)-688-5533
www.liftmoore.com

DRWN BY: JC

DATE: 05/14/09

BEARING, GEAR PRODUCTS ASSY

DRAWING NO.

19430-B



BY: JC
DATE: 4/24/08

ELECTRICAL SWIVEL ASSY 206

DOCUMENT NO.

50471-F

DRAWING SHOWS PARTS BREAK DOWN OF ELECTRIC SWIVEL ASSEMBLY P/N 19438 & MOUNTING HARDWARE.

PART NUMBERS MARKED WITH " * " ARE NOT PART OF THE ASSEMBLY. IF ORDERING ENTIRE SWIVEL ASSEMBLY THESE PARTS MUST BE ORDERED SEPERATELY.

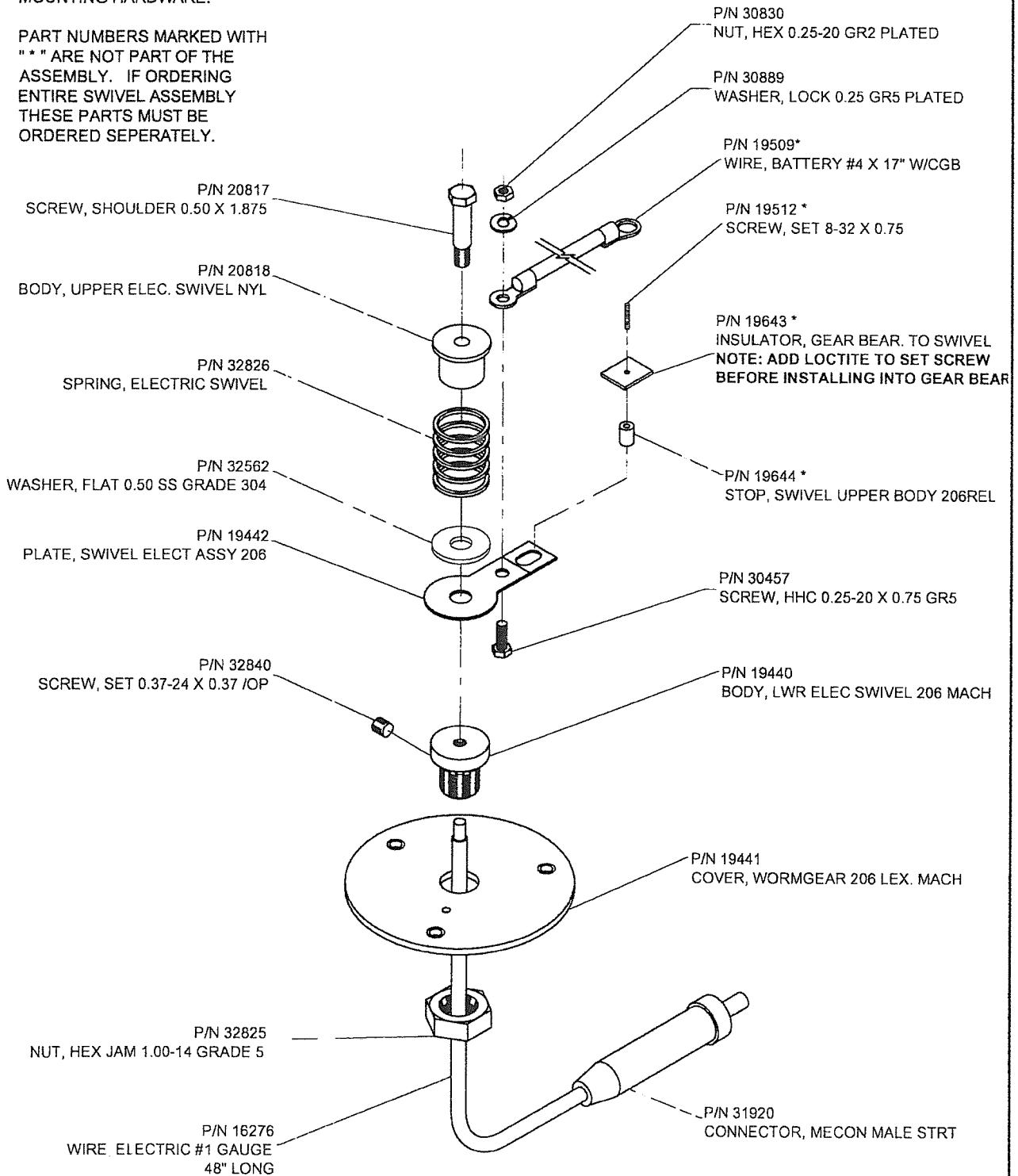

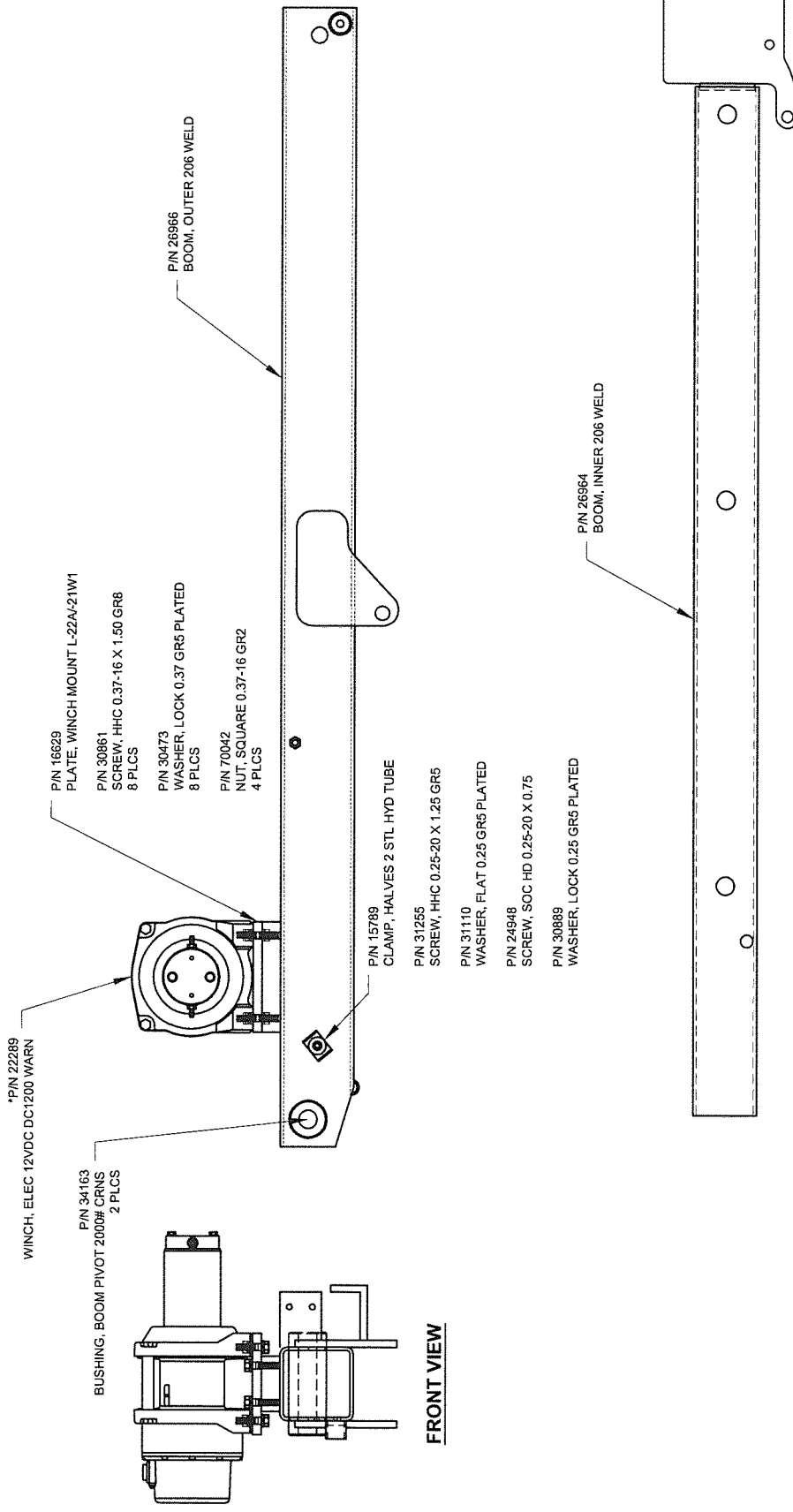

FRONT VIEW

	Houston TX (713)-688-5533 www.liftmoore.com	DRWN BY: AT DATE: 12/22/14	BOOM ASSEMBLY 206 ATB ATB AND NEW WINCH P/N 22289	DRAWING NO. 26967-0
--	---	-------------------------------	--	-------------------------------

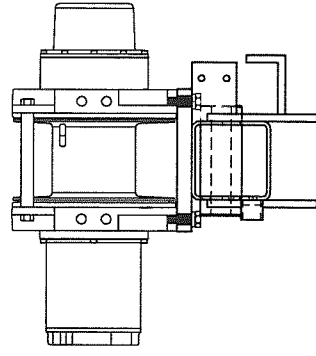

**FRONT
VIEW**

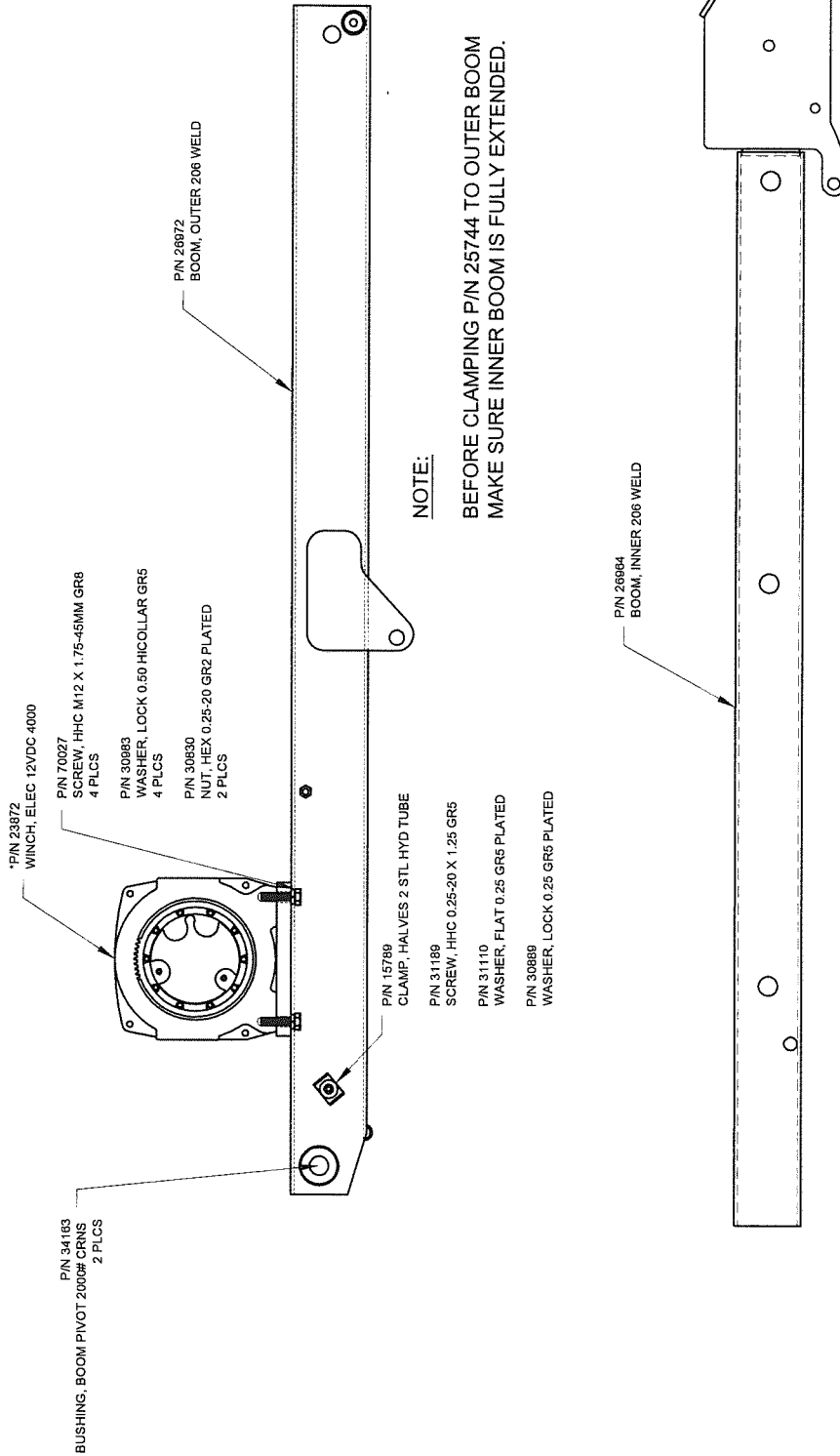

	Houston TX (713)-688-5533 www.liftmoore.com	DRWN BY: JE DATE: 12/19/14	BOOM ASSEMBLY 206W BAIL ATB ATB AND NEW WINCH P/N 23872	DRAWING NO. 26973--0
--	---	-------------------------------	---	--------------------------------

WINCH DC1200 12VDC P/N 22289

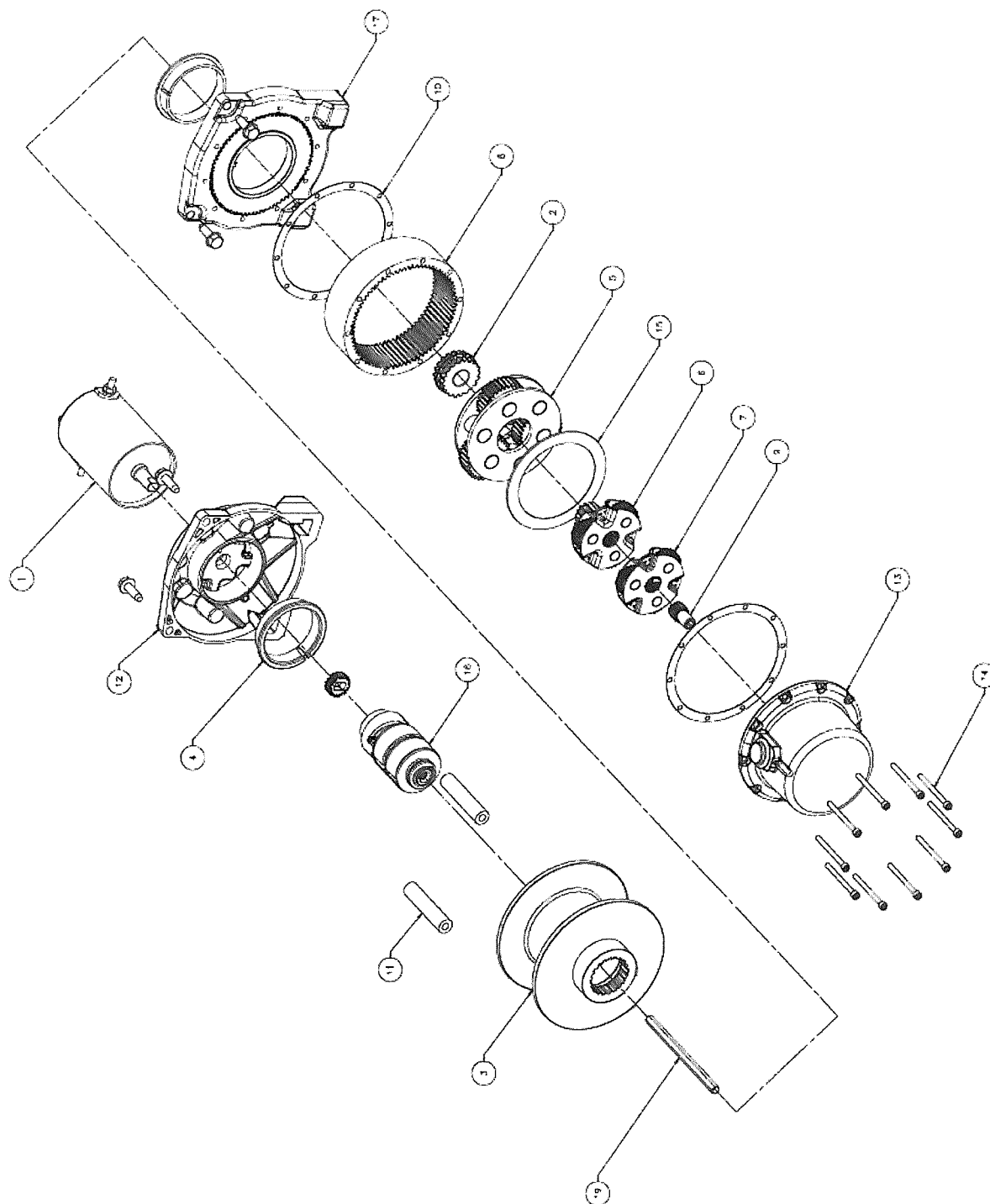

22289-B
05/14/15

HOUSTON, TEXAS
FAX: (800) 824-5559 (USA & Canada)
FAX: (713) 688-6324
PHONE: (713) 688-5533
www.liftmoore.com

SERVICE PARTS LIST: DC1200 HOIST-12V P/N 22289

ITEM REFERENCE	ITEM / KIT No.
1. (MTO)KIT, SVC, MOTOR, BOSCH, Z3500	WI*74853
2. (MTO)S/P SPLINED DRIVE, MIDRANGE	WI*14584
3. DRUM, DC1200, 3.5 DIA.	WI*39821
4. BUSHING DRUM NYLON	WI* 13831
5. CARRIER (PH) ASSY, STAGE 3	WI*28432
6. CARRIER (PH) ASSY, STAGE 2	WI*28431 (WI*34342)
7. CARRIER (PH) ASSY, STAGE 1	WI*28430 (WI*34339)
8. RING GEAR, ARG 75 TOOTH	WI*25308
9. GEAR, SUN, 12 TOOTH, STAGE 1	WI*13874
10. HOUSING, GASKET	WI*13848
11. SVC KIT TIE ROD, ALUM, 0.625 X 2.92	WI*85577
12. SVC KIT DRUM SUPPORT MACHINED DC500 24	WI*85574
13. SVC KIT END HOUSING SUBASSY, CLUTCH PL	WI*85583
14. CPSCR-#10-24 X 2-1/4-HEX SOCKET HEAD-PI	WI*13850
15. WASHER, THRUST, NYLON, MIDRANGE	WI*13826
16. (MTO)S/P BREAK, 2.13 ELECTRIC, NON-BIASED	WI*63548
17. (MTO)S/P DRUM SUPPORT, GEAR END	WI*25986
18. PARTS PACK, (PH) DC2000 HOIST	WI*60049
19. (HEX) SHAFT (PH) DRIVE, 5/16 X 5.5	WI*61844



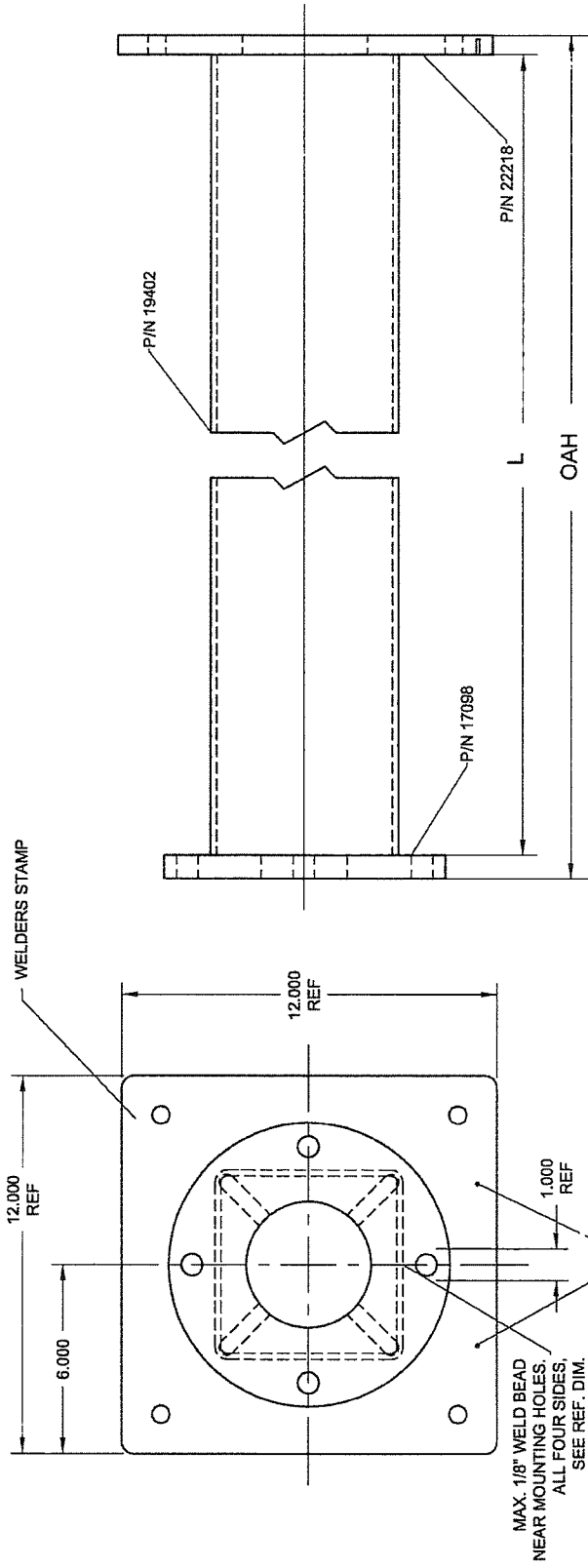

NOTE: L = OAH LESS 1.375"

MAKE SURE DRIVE SCREW HOLES ARE FACING UP

DRAWING NO. 17104-I	PEDESTAL, L-21RF/22AR VAR. HT. WELDMENT	DRAWN BY: LEM DATE: 10/8/96	Houston TX (713)-688-5533 www.lifmoore.com LIFMOORE TRUCK PARTS
-------------------------------	--	--------------------------------	--

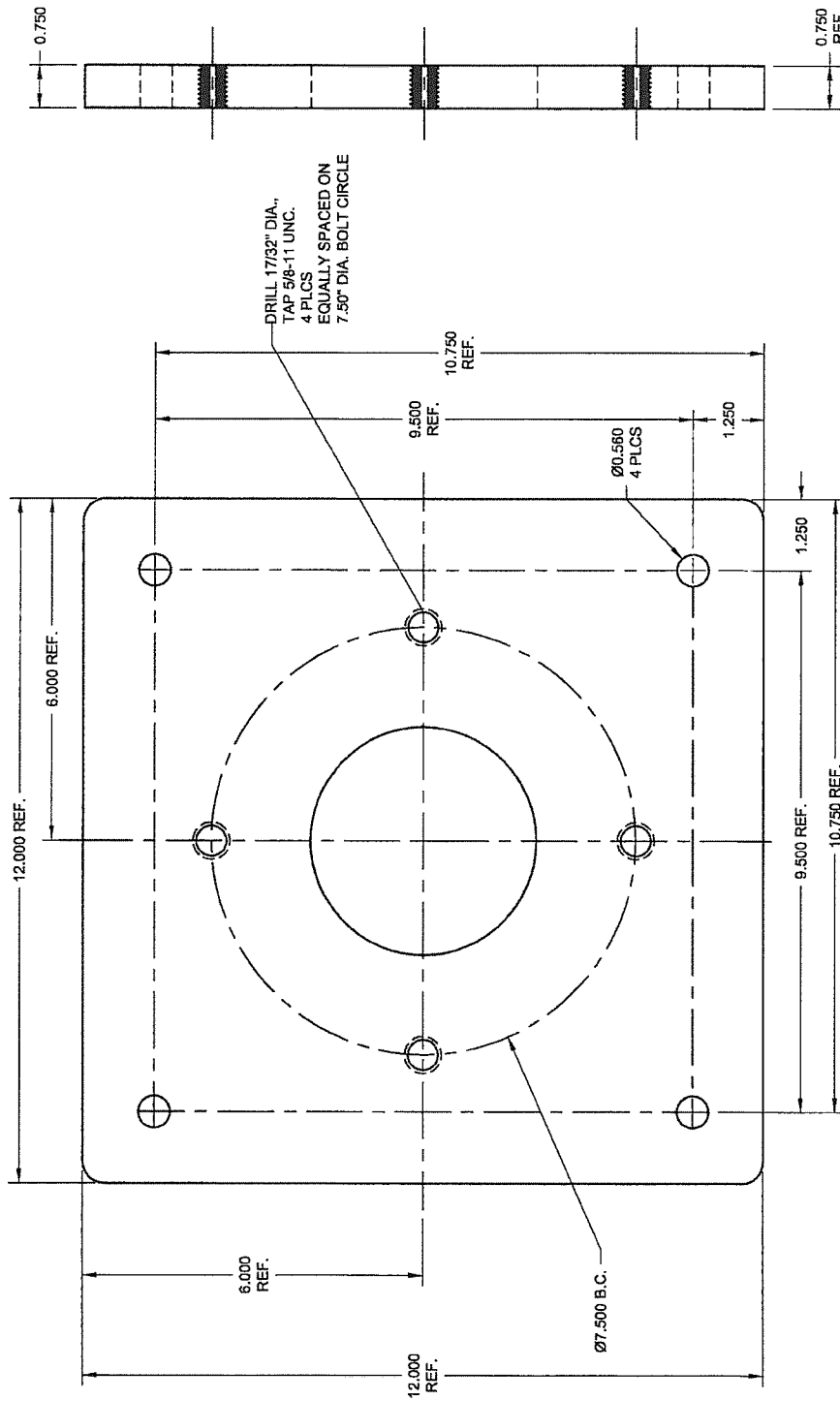

DRAWING NO.

17101-A

PLATE, BASE - FLANGE MOUNT

L-22AR & L-21RF

DRWN BY: LEM

DATE: 10-9-96

Houston TX
 (713)-688-5533
 www.liftmoore.com



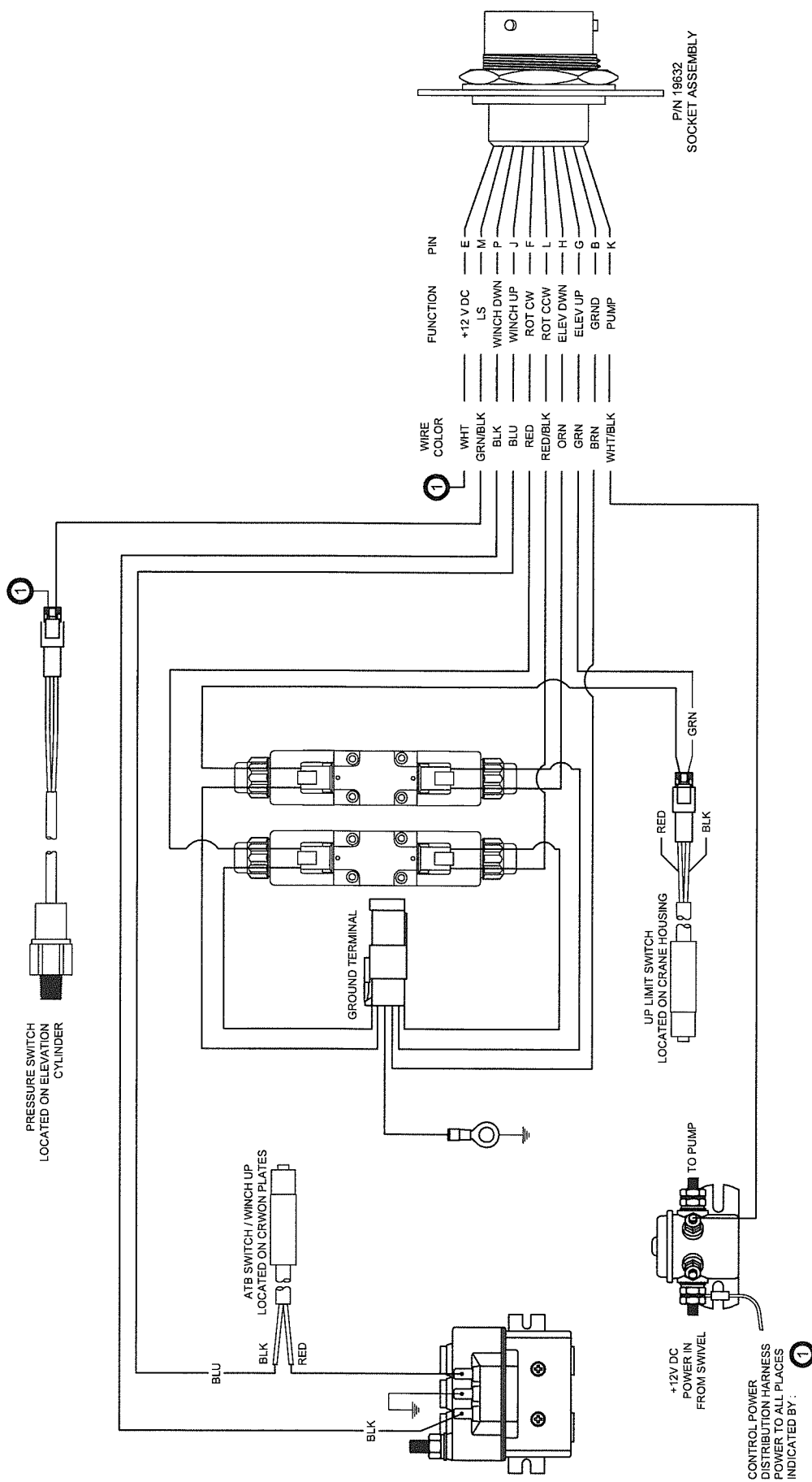

DRAWING NO.
50833-0

SCHEM, CONTROL WIRING 206 W/ATB
DTCH VALVES, ATB

DRWN BY: AA
DATE: 05/08/13

Houston TX
(713)-688-5533
www.liftmoore.com



CONTROL POWER DISTRIBUTION HARNESS POWER TO ALL PLACES INDICATED BY: ①

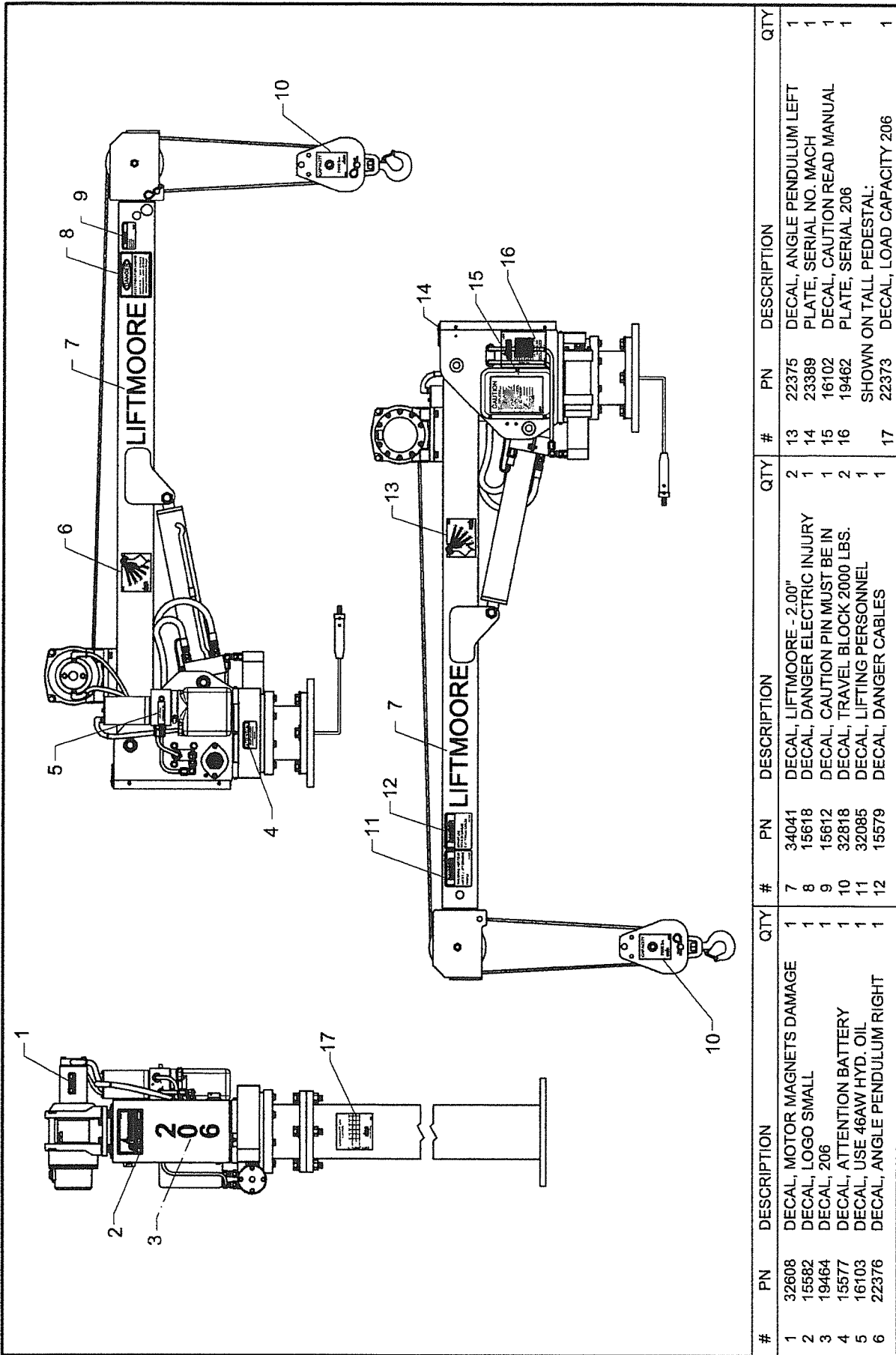

#	PN	DESCRIPTION	QTY	#	PN	DESCRIPTION	QTY	#	PN	DESCRIPTION	QTY
1	32608	DECAL, MOTOR MAGNETS DAMAGE	1	7	34041	DECAL, LIFTMOORE - 2.00"	2	13	22375	DECAL, ANGLE PENDULUM LEFT	1
2	15582	DECAL, LOGO SMALL	1	8	15618	DECAL, DANGER ELECTRIC INJURY	1	14	23389	PLATE, SERIAL NO. MACH	1
3	19464	DECAL, 206	1	9	15612	DECAL, CAUTION PIN MUST BE IN	1	15	16102	DECAL, CAUTION READ MANUAL	1
4	15577	DECAL, ATTENTION BATTERY	1	10	32818	DECAL, TRAVEL BLOCK 2000 LBS.	2	16	19462	PLATE, SERIAL 206	1
5	16103	DECAL, USE 46AW HYD. OIL	1	11	32085	DECAL, LIFTING PERSONNEL	1			SHOWN ON TALL PEDESTAL:	
6	22376	DECAL, ANGLE PENDULUM RIGHT	1	12	15579	DECAL, DANGER CABLES	1	17	22373	DECAL, LOAD CAPACITY 206	1

LIFTMOORE
 TRUCK CRANES
 Houston TX
 (713)-688-5533
 www.liftmoore.com
 DRAWN BY: JC
 DATE: 11/19/09
DECAL DIAGRAM FOR THE
 206REL, RELS & WREL
58284-B
 DRAWING NO.

ITEM	P/N	DESCRIPTION	QTY
2	25130	SCREW, SHOULDER 0.375 X 0.625	1
3	26862	LEVER, ANTI-TWO BLOCK MACH	1
4	33424	BUSHING, 0.37 X 0.50 X 0.50L N	5
5	26848	SCREW, SHOULDER 0.375 X 3.00	1
6	32368	WASHER, FLAT 0.37 SAE SS GR304	3
7	24174	NUT, HEX NYLOC 0.37-16 SS	1
8	26860	LEVER, ATB BAIL 8.375" LT MACH	1
9	17164	SCREW, SOC HD 10-24 X 0.62 SS	6
10	26866	LEVER, BAIL SUPPORT - MACH	2
11	26334	SPACER, LEVER 1.865 MACH	1
12	26859	LEVER, ATB BAIL 8.375" RT MACH	1
13	19628	SHEAVE ASSY 5.90PD X 0.25 ROPE	1
14	32660	SCREW, HHC 0.50-13 X 2.50 GR8	1
15	30835	NUT, HEX NYLOC 0.50-13 GRADE 8	1
16	24960	CLAMP, HOSE SUPPORT 0.25 ID	1
17	30889	WASHER, LOCK 0.25 GR5 PLATED	1
18	26582	SCREW, SOC HD 0.25-20 X 0.37SS	1
19	20376	SWITCH, LIMIT ATB ASSY 2W DTCH	1
20	32639	WASHER, LOCK #10 GR2 PLATED	2
21	17164	SCREW, SOC HD 10-24 X 0.62 SS	2
22	26851	SCREW, SOC HD 0.25-20 X 2.75SS	1
23	33352	WASHER, FLAT 0.25 SAE SS GR304	1
24	25151	SPRING, COMPRESSION	1
25	26849	BALL JOINT ROD END	2
26	26907	SCREW, SHOULDER 0.31 X 0.625	2
27	30998	NUT, HEX 0.31-24 GR2 PLATED	2
28	26947	ALL THREAD STUD .31-24 X 2.0"	1

ITEM	P/N	DESCRIPTION	QTY
29	26852	COVER, SMALL BAIL ATB	1
30	26909	SCREW, SOC HD 10-24 X 0.37 SS	4
31	26910	WASHER, FLAT #10 SS	4

ASSEMBLY

USE LOCTITE TO PROPERLY
SECURE BOLTS

TYPICAL TOLERANCE	LIFTMOORE, INC HOUSTON TX (713)-688-5533
MACHINE ±.005 PLASMA ±1/32 WELD ±1/16	DWG, BAIL ATB ASSEMBLY LA6K / LA10K / L-21 / 206
CAD DRAWING DO NOT SCALE	DRWN BY: AT DATE: 11/14/14 SHEET: 1 OF 1
DWG NO. 58416	

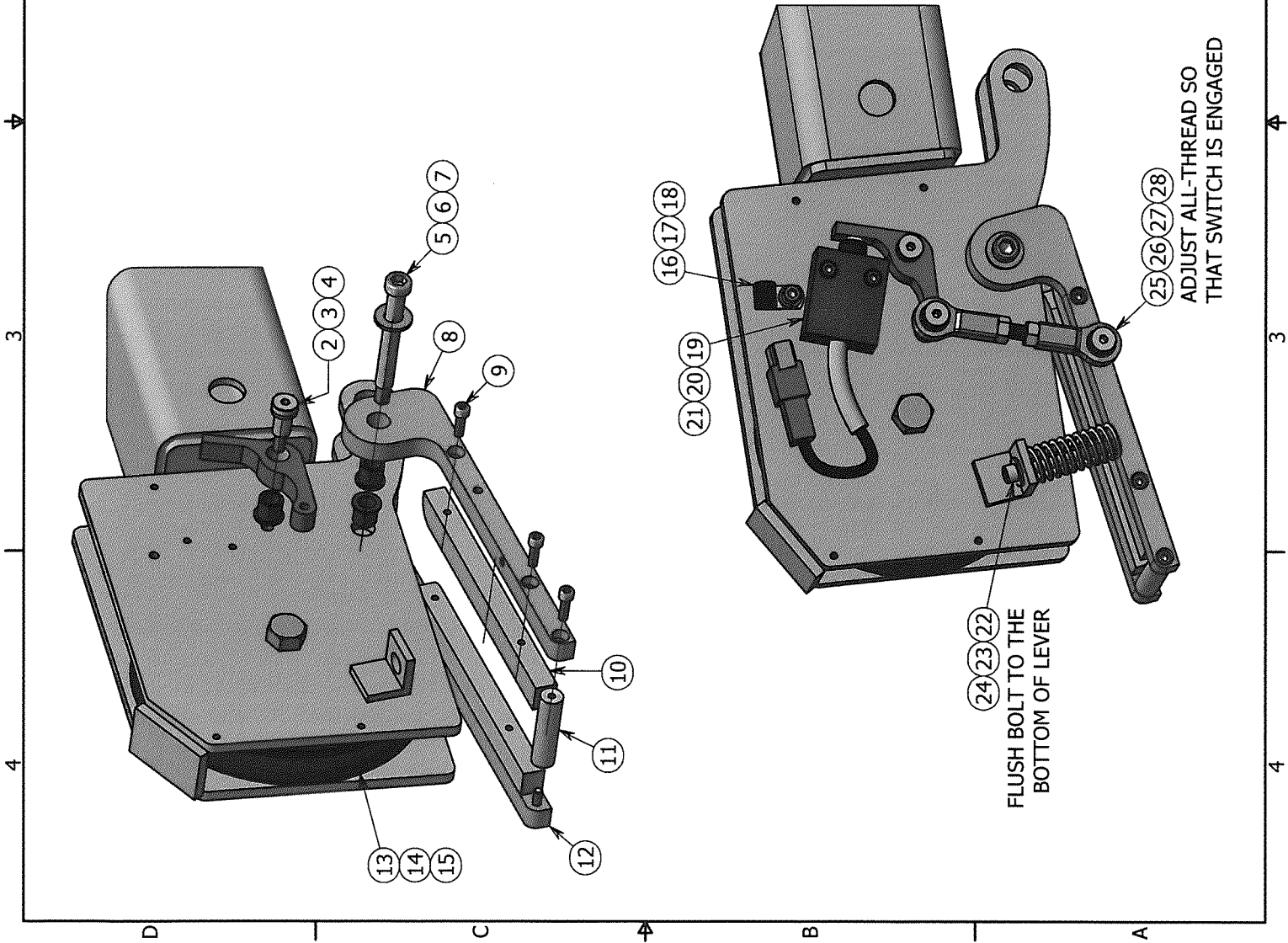

THIS PAGE INTENTIONALLY LEFT BLANK



HOUSTON, TEXAS
FAX: (800) 824-5559 (USA & Canada)
FAX: (713) 688-6324
PHONE: (713) 688-5533
www.liftmoore.com

LIFTMOORE LIMITED WARRANTY

Parts and Structural

Liftmoore, Inc. warrants each LIFTMOORE crane to be free from defects in materials and workmanship for twelve (12) months from the date of delivery to the original customer. Under the terms of this warranty the crane structural components manufactured by LIFTMOORE, Inc. are warranted for thirty-six (36) months from the date of delivery to the original customer. LIFTMOORE, Inc. will repair or replace, as its sole discretion, any equipment or part that is returned f.o.b. to LIFTMOORE, Inc.'s plant at 7810 Pinemont Drive, Houston, Texas 77040, or to one of its authorized dealers, and is found by LIFTMOORE, Inc. or its authorized dealer to have been defective at the time of original delivery.

The foregoing warranty is the exclusive warranty made by LIFTMOORE, Inc. with respect to its cranes and is in lieu of all other warranties. ANY AND ALL OTHER WARRANTIES, EXPRESS OR IMPLIED, INCLUDING ANY WARRANTY OF MERCHANTABILITY OR FITNESS OF ANY CRANE FOR A PARTICULAR PURPOSE OR OPERATION, ARE HERBY EXPRESSLY DISCLAIMED.

The foregoing warranty applies only to LIFTMOORE cranes under normal use and service and does not apply in the event of damage caused by repair or alteration or damage during shipment, accident, negligence, overloading, or misuse, including operator's failure to follow any of the instructions issued with the crane.

This warranty is limited to the original purchaser and is not assignable. In order to submit a claim, the original purchaser must provide a copy of the original invoice for the crane in question within twelve (12) months following the delivery date and within 30 days from the date of repair.

The warranty applies only when the LIFTMOORE crane is used for commercial purposes and does not cover any purchase for use for personal, family or household purposes.

LIMITATION OF LIABILITY: LIFTMOORE, Inc.'s liability for any losses or damages resulting from any cause whatsoever, including LIFTMOORE, Inc.'s NEGLIGENCE or from a defective crane irrespective of whether such defects are discoverable or latent, shall in no event exceed the purchase price of the crane to which losses or damages are claimed, or at the election of LIFTMOORE, Inc., the repair or replacement of the defective crane.

In no event shall LIFTMOORE, Inc. be liable for any special, incidental, or consequential damages, including commercial losses or costs of any kind sustained by purchaser or any other person or for any damages for which purchaser may be liable to other persons by reason of any defect in any LIFTMOORE crane or any part thereof.

LIFTMOORE, Inc. reserves the right to make changes in design or construction of its cranes at any time without obligating itself to make such changes on cranes previously manufactured.

No agent, employee, or representative of LIFTMOORE, Inc. has authority to amend or modify the foregoing warranty or to bind LIFTMOORE, Inc. by any other warranty, guaranty, or assumption of liability.

In the event any provision of this warranty is for any reason held ineffective, the remaining provisions shall remain in full force and effect.

Some states do not allow limitations on how long an implied warranty lasts or the exclusion or limitation of incidental or consequential damages, so the above limitations and exclusions may not apply to you. This warranty gives you specific legal rights, and you may also have other legal rights that vary from state to state.



F1442-A
01/01/2008

HOUSTON, TEXAS
FAX: (800) 824-5559 (USA & Canada)
FAX: (713) 688-6324
PHONE: (713) 688-5533
www.liftmoore.com