

HOUSTON, TEXAS WWW.LIFTMOORE.COM
PHONE: (713) 688-5533 • FAX: (713) 688-6324
FAX: (800) 824-5559 (USA & CANADA)

Installation Instructions

Model 2010, 2700, 3200, 3612, LA10K Series

P/N 22425

ATTENTION !

KEEP THIS MANUAL WITH THE CRANE. OPERATION INSTRUCTIONS ARE CONTAINED IN A SEPARATE MANUAL. NEW OPERATORS SHOULD READ AND BE FAMILIAR WITH THE OPERATING INSTRUCTIONS BEFORE OPERATING THIS CRANE.

ORDER PARTS USING PART NUMBER, CRANE MODEL NUMBER AND CRANE SERIAL NUMBER TO ASSURE ACCURACY OF ORDERS.

MODEL 2010, 2700, 3200, 3612, LA10K INSTALLATION INSTRUCTIONS

TABLE OF CONTENTS

Crane Installation Instructions F917-K..... 1-2

Mounting Pattern DWG. 50217-E.....3

Electrical Installation DWG. 50377-E4

Stability Procedure F691-G5

Stability Test Results F691-G6



F917-K
9/13/17

HOUSTON, TEXAS
FAX: (800) 824-5559 (USA & Canada)
FAX: (713) 688-6324
PHONE: (713) 688-5533
www.liftmoore.com

MODEL 2010, 2700, 3200, 3612, LA10K INSTALLATION INSTRUCTIONS

Read and understand this complete section before starting the crane installation.

Before installing make sure you have all necessary parts. Please refer to the Owner's manual Section 4-1 for the list of parts required for installation. Report any shortages to Liftmoore, Inc. immediately.

1. The mounting must be adequate to support the load and moment rating for the crane as listed:

2010 - 2,000 Lbs. Maximum Load; 10,000 Ft.-Lbs. Moment Rating
2700 - 2,700 Lbs. Maximum Load; 8,100 Ft.-Lbs. Moment Rating
3200 - 3,200 Lbs. Maximum Load; 10,000 Ft.-Lbs. Moment Rating
3612 - 3,600 Lbs. Maximum Load; 12,000 Ft.-Lbs. Moment Rating
LA10K- 2,000 Lbs. Maximum Load; 10,000 Ft.-Lbs. Moment Rating

For truck mounting the crane must be mounted on a structure that will carry the loads to both sides of the truck frame. Sample mounting instructions are available from Liftmoore upon request.

2. Layout the mounting holes for the crane as shown in the drawing No. 50217 in this manual. The base plate for this crane is 15" square with holes for four 1/2" bolts on a 12" square pattern. Drill four 9/16" mounting holes to match the 12" square pattern. Cut a 5.0" hole in the center of the mounting to clear the portion of the quill that projects through the base plate. On cranes with auxiliary controls in the pendant, the rotation is restricted. For these models, locate the rotation stop opposite the point where the boom will be restricted. Bolt the crane onto the truck using the 1/2" x 2-3/4" Grade 8 bolts supplied. If longer bolts are required, at least Grade 8 quality is needed. Tighten the 1/2" Grade 8 bolts to 120 Ft.-Lbs. Other bolts can be used if they are at least Grade 8 strength and no less than 1/2" diameter.

NOTE: Replace the plug in the reservoir with the filler-breather plug shipped with the box of crane parts.

3. A manual disconnect switch with mounting bracket and terminals is provided with the crane. This switch will act as the main power disconnect for the crane. Removing power from the crane during periods of non-use will help to increase the life of the crane's electrical components. The switch should be mounted as near as possible to the crane and in a position which will facilitate its use. Determine the appropriate mounting position for the switch and use the supplied terminals to splice in to the crane's main power cable. We recommend that this be below the welding connector supplied with the crane. Drawing No. 50377 illustrates where we recommend installing the disconnect switch, welding connector and circuit breaker.(Always turn off power when crane is not in use.)

4. The vehicle's battery should have a capacity of at least 90 Amp-Hr. A second battery located near the crane is strongly advised. This will keep the voltage as near 12 Volts as possible while the crane is running. The life of the crane's electrical components will be longer if the voltage is as near 12 volts as possible. A deep cycle battery provides the best battery life. Connect the second battery in parallel with the truck's original equipment battery using at least No. 1 battery wire.

5. Install the 150 Amp circuit breaker near the battery supplying the crane and on the battery's positive line with a universal or marine type wing nut lug terminal. This breaker is to protect the battery in event of an accidental grounding of the positive wire anywhere along its length. Use a section of the wire and the terminals supplied to connect between the battery and the circuit breaker. See drawing No. 50377.

6. Run the No. 1 battery cable along the inside of the chassis frame to the circuit breaker if a second battery is not used. Make sure that the cable is protected avoiding sharp edges and heat sources such as the muffler or catalytic converter. Use loom for protection whenever the cable passes through the body, frame or other metal objects. The quick disconnect under the crane



MODEL 2010, 2700, 3200, 3612, LA10K INSTALLATION INSTRUCTIONS, Cont.

should be accessible. Always leave this disconnected to take the crane out of the electrical circuit when it is not in use.

7. Install the extra ground wire supplied from the negative battery terminal to the truck's main frame. Grounding the battery to the frame protects the chassis wiring. Leave the regular ground to the engine as is. The battery end of both wires can be clamped together using a universal type battery connector. This ground must be in place to protect the truck's wiring and for efficient operation of the crane. A good ground must exist for the crane to work. Leaving this ground wire off can damage the truck's chassis wiring as it may then carry some of the crane circuits current. This wire must be as large as the battery lead wire for the system to operate efficiently.

8. A boom support must be installed to secure the boom when the truck is moved. Mount an eye on the boom rest for the hook as shown in Liftmoore's Accessories bulletin. The wire rope can then be used to secure the boom in the rest.

9. An outrigger must be installed to keep the truck and the crane as level as possible under all expected working conditions. Keeping the crane level reduces the loads on the rotation gear. This will also protect the truck's springs, axle and wheels when heavy loads are suspended from the crane. OSHA requirements require a stability test be performed on this installation. If the installation does not pass the stability test contact Liftmoore for information on derating the crane in the unstable areas.

10. Additional truck springs may be necessary depending upon the size of the truck and location of the crane on the truck. Add springs to bring the truck level after all equipment is mounted.

11. The crane is now ready to use. Read the Operating Instructions section of the Owner's Manual before operating the crane. When operating the crane for the first time run the cylinders through their full extension cycle to purge any air from the cylinder. Operate the crane to assure complete operation of all functions.

Operating speeds are approximately as follows:

Rotation of one revolution: 70 Seconds
Boom Elevation (75 Degrees): 35 Seconds
Boom Extension (6 Feet): 35 Seconds
Winch Line Speed: 17 Ft. per Min.

12. If equipped with an anti two-block device, verify that the anti two-block will stop extension out, boom down and winch up when the weight on the device is lifted by either function. Make sure that the weight is on the live or running wire rope. The Crane Assembly drawing in the owner's manual Section 4-2 illustrates how the weight should be installed on the line.

13. Place these Installation Instructions and the Owner's Manual with Operating Instructions in a convenient place for the user to find and use before operating the crane.

14. When complete, turn off the crane power switch and disconnect the welding connector.

15. Load Chart Decal is to be placed on the truck body for easy visibility by the user.



F917-K
9/13/17

HOUSTON, TEXAS
FAX: (800) 824-5559 (USA & Canada)
FAX: (713) 688-6324
PHONE: (713) 688-5533
www.liftmoore.com

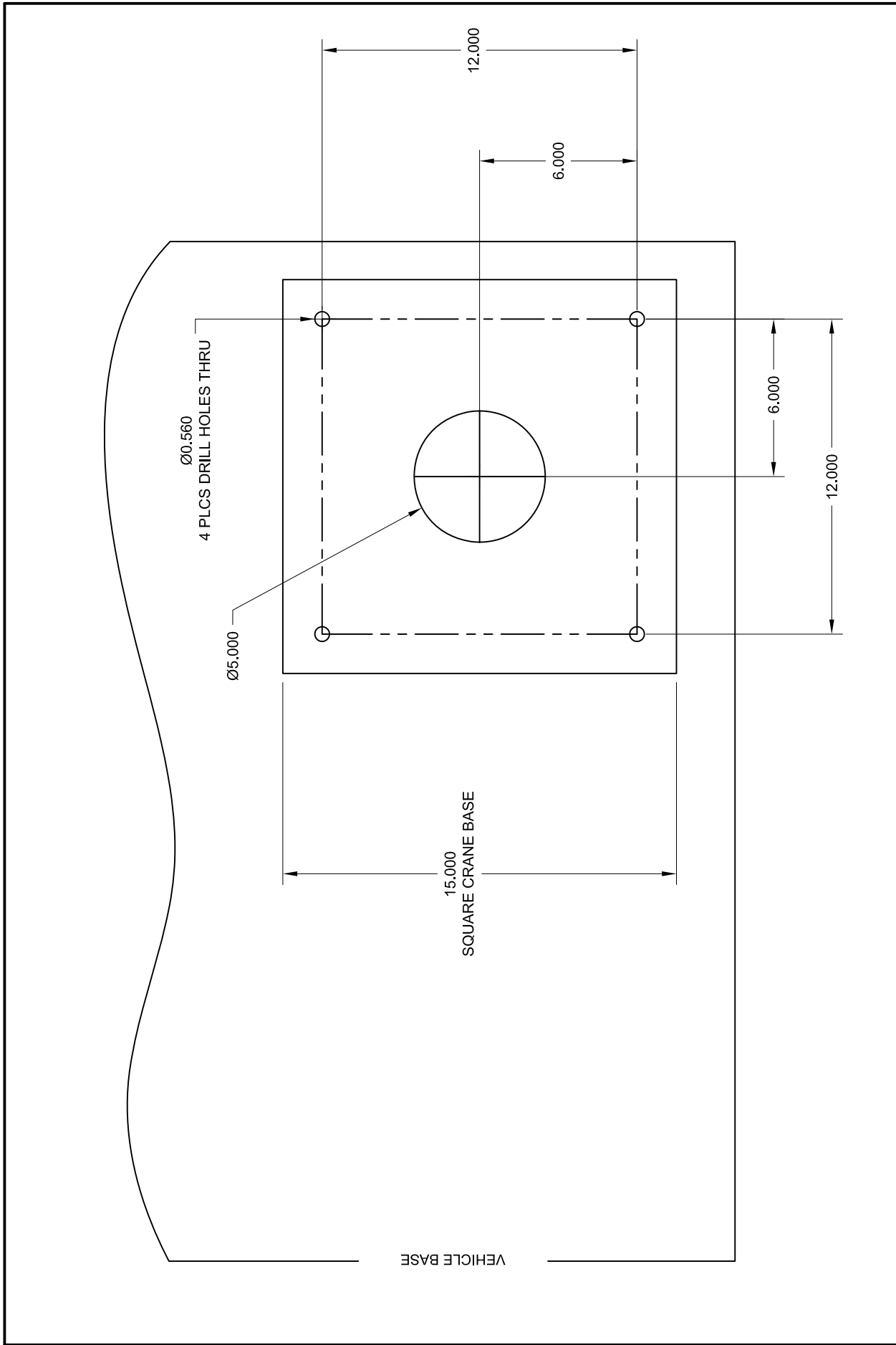

Houston TX (713)-688-5533 www.liftmoore.com	DRAWN BY: JC DATE: 9/10/08	MOUNTING PATTERN FOR 1032/2000/2010/2700/3200/3612/LA10K	DRAWING NO. 50217-E
---------------------------------------------------	-------------------------------	-------------------------------------------------------------	------------------------

SUGGESTED WIRING SCHEMATIC FOR 208, 2000, 2700AR MODEL AND SMALLER CRANE
INSTALLATION:

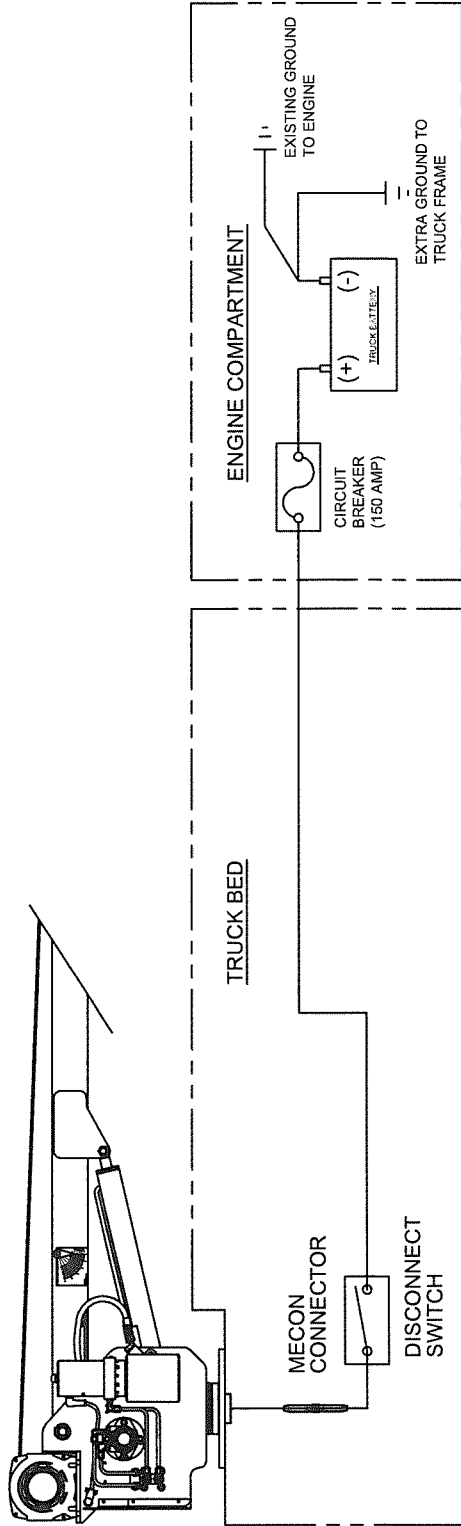

SUGGESTED WIRING SCHEMATIC FOR 3200 UP TO 4000 MODEL CRANE INSTALLATION:

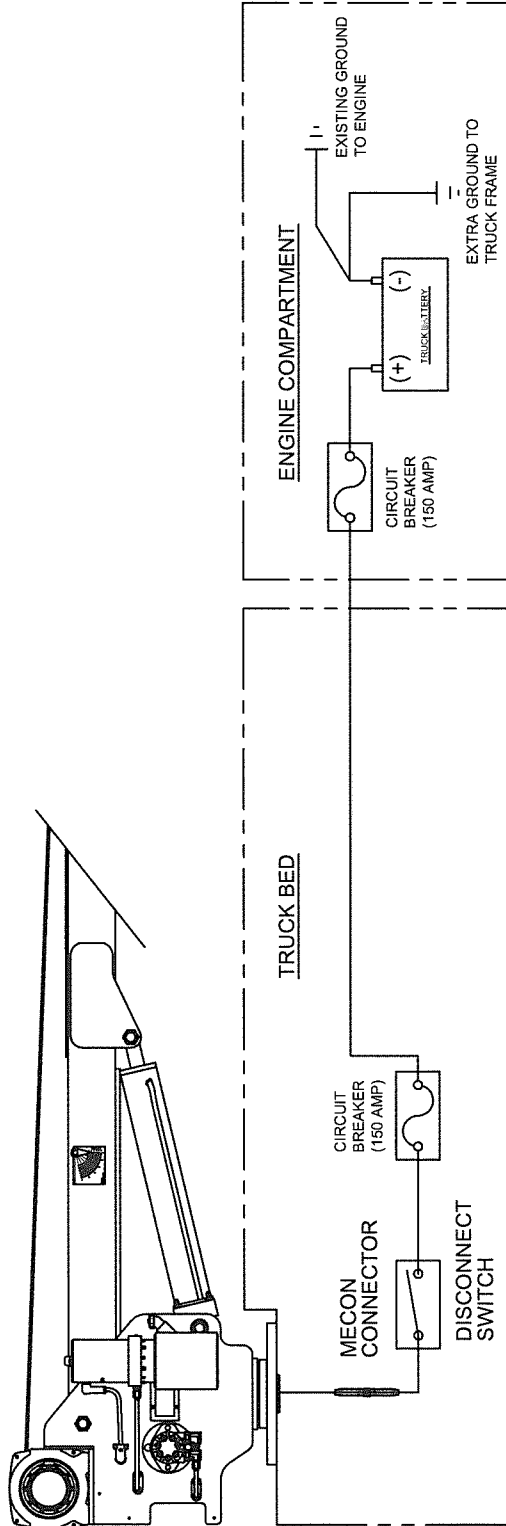

Houston TX
(713)-688-5533
www.lifmoore.com

DRWN BY: JC

DATE: 06/03/08

SCHEM, CRANE ELEC. INSTAL-ELEC
FOR 4000 & SMALLER ELECTRIC CRANES

DRAWING NO.

50377-E



VEHICLE STABILITY TEST

12/6/12

OSHA requires a stability test be completed by the installer. A qualified person shall perform this test. Please call Liftmoore for any assistance required in completing this test.

Test Preparations:

- Use as level of a test site as possible.
- Engage parking brake on vehicle.
- Set outriggers, jackstands, or other stability device in place.
 - Vehicle tires should remain in contact with the ground.
 - The vehicle should be level.

Fill out test form:

- Complete the vehicle and crane data at the top of Page 2 of this form.
- Use a known weight to determine the *Testing Load Radius*.

Test Procedure:

Determine Area W1 Length

1. With the crane extended to the *Testing Load Radius* over the rear of the truck, lift the load. Keep the load less than 4" off of the ground.
2. Rotate the load counterclockwise. Monitor all vehicle tires to ensure they remain in contact with the test surface.
3. When one of the vehicle's tires breaks contact with the ground, stop the rotation.
4. Use a protractor to determine this angle. Write this angle on the Stability Test Results as *Area Y*.
5. Keeping the load off of the ground, retract or elevate the boom until all tires are in contact with the test surface.
6. Continue rotating the load counterclockwise while monitoring all vehicle tires.
7. When one of the vehicle's tires breaks contact with the ground, stop the rotation.
8. Keeping the load off of the ground, retract or elevate the boom until all tires are in contact with the test surface.
9. Repeat this procedure until either the vehicle prevents further rotation or a 180 degree rotation of the load is reached.
10. Record the load radius in feet at this point on the Stability Test Results as *Area W1 Length*.

Determine Area W2 Length

11. Return the load to the rear of the vehicle and extend the load to the *Testing Load Radius*. Keep the load less than 4" off of the ground.
12. Rotate the load clockwise. Monitor all vehicle tires to ensure they remain in contact with the test surface.
13. When one of the vehicle's tires breaks contact with the ground, stop the rotation.
14. Use a protractor to determine this angle and write this angle on the Stability Test Results as *Area Z*.
15. Keeping the load off of the ground, retract or elevate the boom until all tires are in contact with the test surface.
16. Continue rotating the load clockwise while monitoring all vehicle tires.
17. When one of the vehicle's tires breaks contact with the ground, stop the rotation.
18. Keeping the load off of the ground, retract or elevate the boom until all tires are in contact with the test surface.
19. Repeat this procedure until either the vehicle prevents further rotation or a 180 degree rotation of the load is reached.
20. Record the load radius in feet at this point on the Stability Test Results as *Area W2 Length*.

Record Stability Test Results on Placard

21. Record the information from the Stability Test Results on the CRANE TRUCK STABILITY plate (P.N. 18600) and install the plate in a visible position on the vehicle, preferably near the crane.

THIS TEST IS NOW COMPLETE

STABILITY TEST FORM

Operational limits of this vehicle

VEHICLE INFORMATION	CRANE INFORMATION
Year _____	Model _____
Make _____	Serial Number _____
Model _____	Moment Rating (ft-lbs.) _____
VIN _____	

Determine The **Testing Load Radius** by using the following:

Moment Rating (ft-lbs.) _____
 Multiply by 1.18 x _____
 Divide by known weight + _____
Testing Load Radius (ft.) = _____

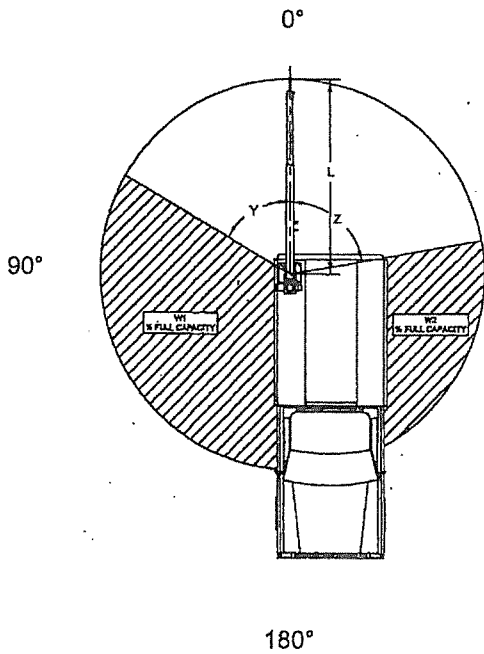

Area W1 Length _____
Testing Load Radius (ft.) + _____
 Multiply by 100 x _____
 W1 % Rated Capacity = _____

Area W2 Length _____
Testing Load Radius (ft.) + _____
 Multiply by 100 x _____
 W2 % Rated Capacity = _____

STABILITY TEST RESULTS	
Area Y:	_____ Degrees
Area Z:	_____ Degrees
Area W1 Rated Capacity:	_____ %
Area W2 Rated Capacity:	_____ %

Test performed by: _____

Date: _____