

HOUSTON, TEXAS www.liftmoore.com
PHONE: (713) 688-5533 • FAX: (713) 688-6324
FAX: (800) 824-5559 (USA & CANADA)

Operating & Installation Instructions

Manual Out / Crank Down 25k ft.lbs. Outriggers

!ATTENTION!

KEEP THIS MANUAL WITH THE CRANE. OPERATION INSTRUCTIONS ARE CONTAINED IN A SEPARATE MANUAL. NEW OPERATORS SHOULD READ AND BE FAMILIAR WITH THE OPERATING INSTRUCTIONS BEFORE OPERATING THIS CRANE.

ORDER PARTS USING PART NUMBER, CRANE MODEL NUMBER AND CRANE SERIAL NUMBER TO ASSURE ACCURACY OF ORDERS.

**TABLE OF CONTENTS
P/N 20552**

**MANUAL OUT / CRANK DOWN
25k ft.lbs. OUTRIGGERS**

<u>DESCRIPTION</u>	<u>LOCATION</u>
TABLE OF CONTENTS.....	FORM 1125-D / P.2
OPERATING INSTRUCTIONS.....	FORM 1125-D / P.3
INSTALLATION INSTRUCTIONS	FORM 1125-D / P.4
CENTER TUBE DIMENSIONS TABLE	FORM 1964-0 / P.5
INSTALLATION DRAWING	DRAWING 50507-C
OUTRIGGER ASSEMBLY DRAWING	DRAWING 58113-C
DETENT PIN ASSEMBLY	DRAWING 32492-C



OPERATING INSTRUCTIONS

MANUAL OUT / CRANK DOWN 25k ft.lbs. OUTRIGGERS

Before using the crane, the outriggers must be set properly. It is advised that the front wheels of the truck are blocked and the parking brake set to prevent the truck from rolling.

Always keep the truck as level as possible when operating the crane. Set the outriggers on firm ground that will not yield under load.

Check for overhead obstructions and especially for electrical wires. The crane must always be more than 10 Feet away from electrical wires.

Raise the outrigger detent pin and pull the outrigger out until the pin is engaged in the stop hole. Do not use the outrigger unless this pin is fully engaged. There are only two positions for the pull out section, either fully retracted or fully extended.

Manually lower the innermost telescoping portion of the jack by raising the "U" shaped handle. This handle releases the pins holding the manual outrigger section in place. After lowering, make sure the pins are set by pushing down on the handle until it contacts the jack's outer tube. Then crank the jack until there is lifting of the truck bed. The higher the truck, the less the truck must tilt to counterbalance the crane and its load. Leave the truck wheels in contact with the ground. Set the opposite side outrigger using the same method.

The outrigger is set and the crane is ready for use.

NOTE: At no time should the tire on the opposite side from the lifting side be raised above the ground. If the tire leaves the ground, relocate the truck closer to the load to prevent this.

Do not operate the crane until you have read and understand the crane's operation as explained in the manual.

To put up the outrigger, crank the outrigger so that the cranked section is fully raised, then raise the manual portion by lifting the "U" shaped handle and raising the manual section. Make sure the pins engage the manual section and that the handle is again in its down position. Lift the detent pin and slide the outrigger in. Make sure the detent pin is engaged into the outrigger. The outrigger can slide out during a sharp turn if the detent pin is not engaged.



INSTALLATION INSTRUCTIONS

MANUAL OUT / CRANK DOWN 25k ft.lbs. OUTRIGGERS

Refer to Drawing No. 50507 for outrigger layout.

Read these instructions completely before starting installation.

This kit includes the outrigger center tube, with two manual pull-out sections, and two crank down jacks.

Before mounting the outrigger center tube, orient the outrigger so that the longer manual pull out section is on the same side of the truck as the crane.

IMPORTANT: The outrigger center tube must be supported at the truck frame, at its outer end under the crane's structural support, and at the end opposite the crane. The center tube should not be supported by the body sheet metal.

Locate the outrigger as close to the crane as possible.

1. Set the outrigger with clearance from the truck body so that the pull out or extendable portion will clear the body when fully retracted. Set the vertical height so that the outrigger will be able to penetrate at least 6" below the ground. The outrigger jack is 25" long when retracted. It extends a maximum length of 50". The crank travel length is 13" and the total extension is 25".
2. Fabricate an "L" shaped mounting bracket similar to the one shown on drawing 50507 (also see drawing for center tube dimensions). The bracket is not furnished. Weld the cross tube securely to the bracket. This will provide support for the outrigger at the truck frames.
3. Weld the outer end of the cross tube securely to the crane support structure using 4" channel or stronger steel bars. This outer end of the cross tube must be supported to carry the crane load and prevent bending of the center tube, and/or truck body. This should be done below the crane and on the side opposite the crane.
4. Check the outrigger for operation. Especially note that the detent pins on the pull out and drop down sections fully engage in all operating positions.

Place labels on the crank down jacks warning of crushing injury. The outrigger is ready for use!



**OUTRIGGERS CENTER TUBE
DIMENSIONS TABLE**

<i>Outrigger Model</i>	<i>Center Tube Size</i>
<i>Outrigger 10K</i>	<i>2.50" X 5.00" X 0.18" W</i>
<i>Outrigger 12K</i>	<i>2.50" X 5.00" X 0.18" W</i>
<i>Outrigger 18K</i>	<i>4.00" X 6.00" X 0.25" W</i>
<i>Outrigger 25K</i>	<i>5.00" X 7.00" X 0.18" W</i>
<i>Outrigger 36K</i>	<i>6.00" X 8.00" X 0.18" W</i>
<i>Outrigger 50K</i>	<i>7.00" X 9.00" X 0.18" W</i>
<i>Outrigger 72K</i>	<i>8.00" X 10.00" X 0.25" W</i>



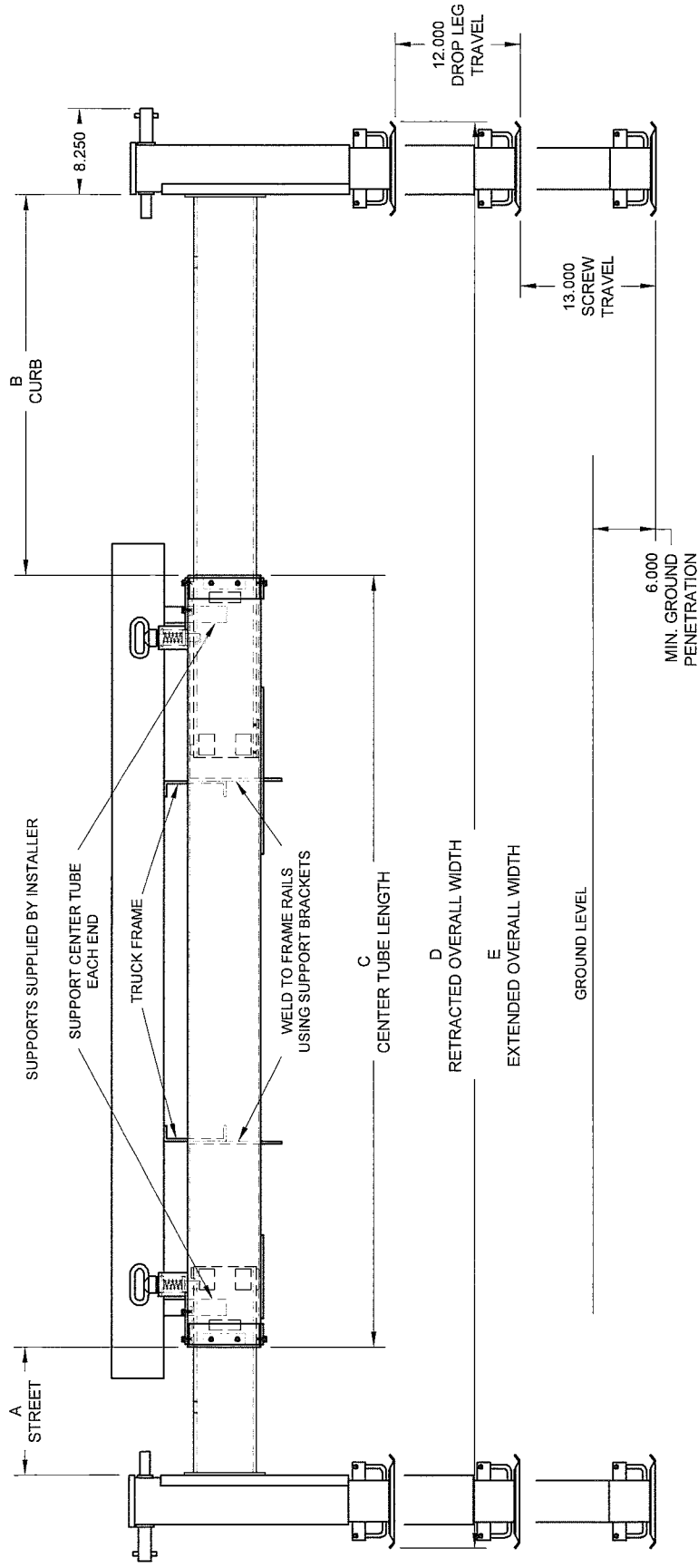

MODEL	DESCRIPTION	DIMENSION A	DIMENSION B	DIMENSION C	DIMENSION D	DIMENSION E
MODEL 38426	36CMOCD-12SMOCD	12"	36"	74"	89"	137"
MODEL 38427	36CMOCD-12SMOCD	12"	36"	79.5"	94.5"	142.5"
MODEL 38629	36CMOCD-SFXNJ	0"	36"	79.5"	87.25"	123.25"
MODEL 38810	36CMOCD-SFXCD	0"	36"	79.5"	94.25"	130.25"
MODEL 38862	24CMOCD-24SMOCD	24"	24"	79.5"	94.5"	142.5"

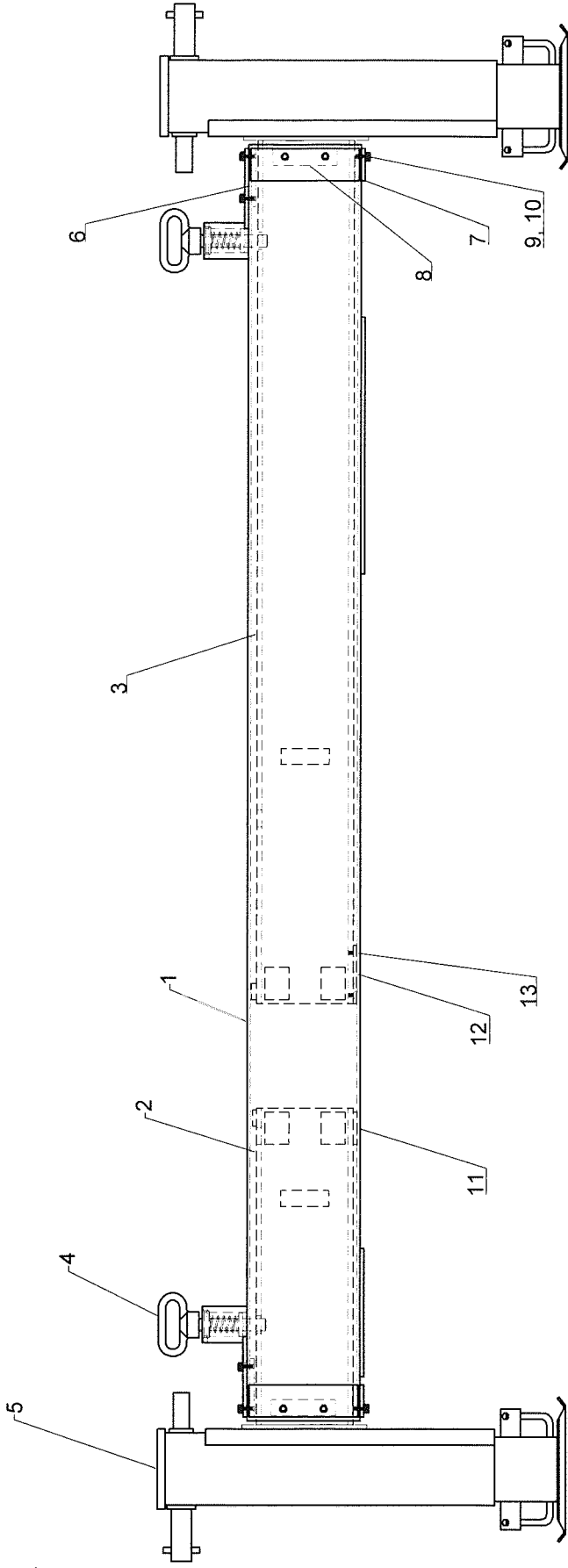

ITEM	DESCRIPTION	OUTRIGGER												
		38426 QTY	38427 QTY	38629 QTY	38810 QTY	38962 QTY								
1	CENTER OUTR.	17841	17844	19894	21971	18063								
2	STREET SIDE OUTR.	17851	17851	NONE	NONE	23097								
3	CURB SIDE OUTR.	17847	17847	17847	17847	23098								
4	DETENT ASSY	32492	32492	32492	32492	32492								
5	CRANK DOWN JACK	15560	15560	15560	15560	15560								
6	TOP SPACER	33292	33292	33292	33292	33292								
7	BOTTOM SPACER	33951	33951	33951	33951	33951								
8	SIDE SPACER	16820	16820	16820	16820	16820								
9	SCREW	30457	30457	30457	30457	30457								
10	LOCK WASHER	30889	30889	30889	30889	30889								
11	STREET NYLON PAD	NONE	NONE	NONE	NONE	34032								
12	CURB NYLON PAD	34032	34032	34032	34032	34032								
13	SCREW	33614	33614	33614	33614	33614								

*SEE INSTALLATION DRAWING FOR OUTRIGGER MODEL NUMBER DESCRIPTION



Houston TX
(713)-688-5533
www.liftmoore.com

DRWN BY: JC
DATE: 05/05/09

OUTRIGGER 25K MOCD
PARTS LIST

DRAWING NO.
58113-C

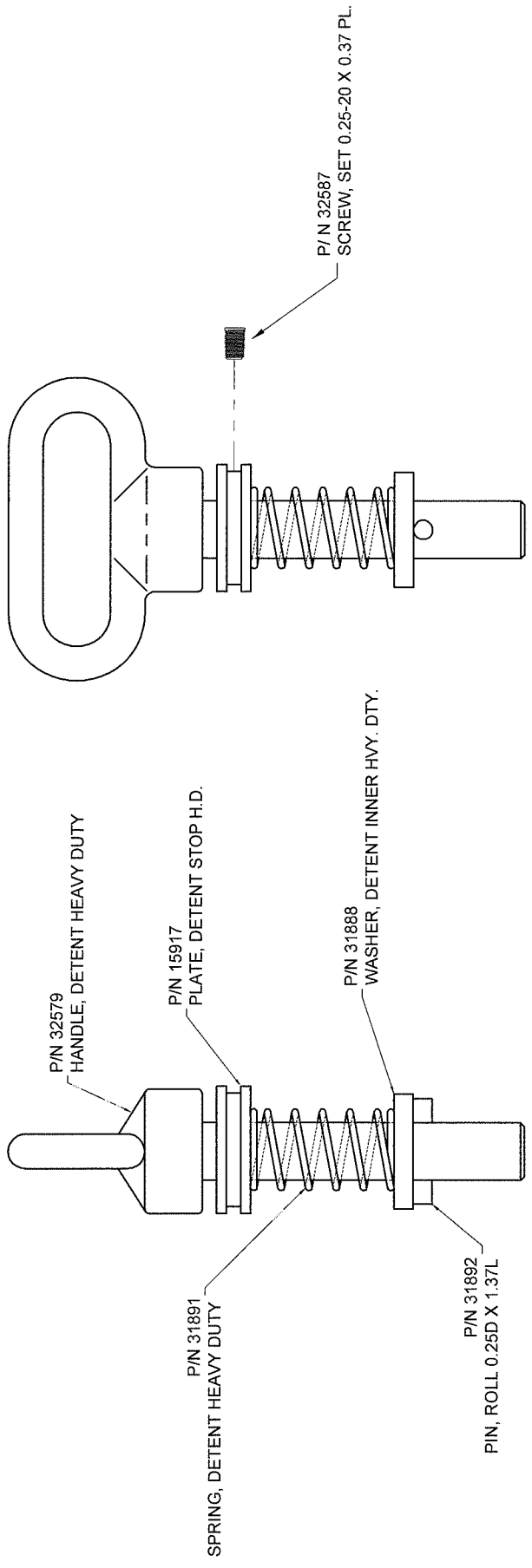

P/N 32579
HANDLE, DETENT HEAVY DUTY

P/N 15917
PLATE, DETENT STOP H.D.

P/N 31888
WASHER, DETENT INNER HVY. DTY.

P/N 31891
SPRING, DETENT HEAVY DUTY

P/N 31892
PIN, ROLL 0.25D X 1.37L

P/N 32587
SCREW, SET 0.25-20 X 0.37 PL.



Houston TX
(713)-688-5533
www.liftmoore.com

DRWN BY: JC
DATE: 01/24/07

DETENT, INNER ASSEMBLY H.D.

DRAWING NO.

32492-C